



AVP, Kotnikova ulica 19a, SI-1000 Ljubljana, tel.: 01 478 8430, vozila@avp-rs.si
STSA, Kotnikova ulica 19a, SI-1000 Ljubljana, tel.: +386 1 478 8430, vozila@avp-rs.si
37141-70/2024/7

POTRDILO O EU-HOMOLOGACIJI
EU TYPE-APPROVAL CERTIFICATE

Sporočilo o:
Communication concerning:

- EU-homologaciji
- *EU type-approval*
- ~~razširitvi EU-homologacije~~
- ~~extension of EU type-approval~~
- ~~zavrnitvi EU-homologacije~~
- ~~refusal of EU type-approval~~
- ~~preklicu EU-homologacije~~
- ~~withdrawal of EU type-approval~~

samostojne tehnične enote: naprave za zmanjševanje hrupa
of a type of STU: noise-abatement device

glede na Priloge IX k Delegirani uredbi Komisije (EU) št. 134/2014, kakor je bila nazadnje spremenjena z Delegirano uredbo Komisije (EU) št. 2023/2724
with regard to Annex(es) IX to Commission Delegated Regulation (EU) No 134/2014, as last amended by Commission Delegated Regulation (EU) No 2023/2724

Številka EU-homologacije: **e26*134/2014*2023/2724G*08224*00**
EU type-approval number:

Razlog za razširitev: /
Reason for extension:

ODDELEK I
SECTION I

- | | | |
|-------|---|---|
| 0.7 | Znamke (tovarniška imena proizvajalca):
<i>Make(s) (trade name(s) of manufacturer)</i> | AKRAPOVIC |
| 0.8 | Tip:
<i>Type:</i> | M-HHA002 |
| 0.8.1 | Trgovska imena (če obstajajo):
<i>Commercial name(s) (if available):</i> | / |
| 0.9 | Ime podjetja in naslov proizvajalca:
<i>Company name and adress of manufacturer:</i> | AKRAPOVIC D.D.
MALO HUDO 8A
1295 IVANCNA GORICA
Slovenia |

-
- 0.9.1. Imena in naslovi proizvodnih tovarn:
Name(s) and addresse(s) of assembly plant(s): AKRAPOVIC D.D.
MALO HUDO 8A
1295 IVANCNA GORICA
Slovenia
- AKRAPOVIČ D.D., PE ČRNOMELJ
ULICA HEROJA STARIHA 24
8340 ČRNOMELJ
Slovenia
- 0.9.2. Ime in naslov zastopnika
proizvajalca (če obstaja):
*Name and adress of manufacturer's
representative (if nay):* /
- 0.10. Pri samostojni tehnični enoti,
vozila, za katere je namenjena:
*In the case of seperate technical unit,
vehicle(s) for which is intended for:* KTM
- 0.10.1. Tip:
Type: glej poročilo o preskusu
see the test report
- 0.10.2. Variante:
Variant(s): vse
all
- 0.10.3. Izvedenke:
Version(s): vse
all
- 0.10.4. Trgovska imena (če obstajajo):
Commercial name(s) (if available): glej poročilo o preskusu
see the test report
- 0.10.5. Kategorija, podkategorija in
podpodkategorija vozila:
*Category, subcategory and
sub-subcategory of vehicle:* L3e-A3

ODDELEK II
SECTION II

1. Tehnična služba, pristojna za izvajanje preskusov:
Technical service responsible for carrying out the tests: TÜV SÜD Auto Service GmbH
Westendstraße 199
D-80686 München
Germany
2. Datum poročil o preskusu:
Date of test report(s): 08.09.2025
3. Številka poročil o preskusu:
Number of test report(s): 25-00067-CM-GBM-00
4. Opombe:
Remarks: glej Dodatek
see Addendum
- 4a. Homologacija je:
The approval is: **podeljena**
granted
- 4a.1. Homologacija se podeli na podlagi člena 40
Uredbe (EU) št. 168/2013, tako da je njena
veljavnost omejena do: ne pride v poštev
*The approval is granted in accordance with Article
40 of Regulation (EU) No 168/2013 and its
validity is thus limited to:* *not applicable*
5. ~~Omejitve veljavnosti:~~
~~*Restrictions of validity:*~~ /
6. ~~Uporabljene opustitve:~~
~~*Waivers applied:*~~ /
- Kraj:
Place: 1000 LJUBLJANA
- Datum:
Date: 06.10.2025
- Ime in podpis:
Name and signature: mag. Tomaž Svetina, univ.dipl.inž.str.
vodja sektorja za vozila

TOMAŽ
SVETINA Digitalno podpisal
TOMAŽ SVETINA
Datum: 2025.10.14
07:24:14 +02'00'

Temu sporočilu je priložen seznam dokumentov, ki so deponirani pri homologacijskem organu, ki je odobril to homologacijo in jih je na zahtevo mogoče dobiti:

glej kazalo opisne dokumentacije št. e08224 Rev.00

The list of documents deposited with the Administrative Service which has granted approval is annexed to this communication and may be obtained on request:

see index to information package No e08224 Rev.00

Dodatek k potrdilu o EU-homologaciji s številko EU-homologacije:
Addendum to the EU type-approval certificate with EU type-approval number:
e26*134/2014*2023/2724G*08224*00

1. **Omejitve uporabe samostojne tehnične enote: naprave za zmanjševanje hrupa:**
Restriction of use of the STU: noise-abatement device:

glej prilogo 2 testnega poročila 25-00067-CM-GBM-00
see enclosure 2 of the test report 25-00067-CM-GBM-00

2. **Posebni pogoji za vgradnjo samostojne tehnične enote: naprave za zmanjševanje hrupa:**
Special conditions for the mounting of the STU: noise-abatement device:

glej proizvajalčeva navodila za vgradnjo
see manufacturer's instruction manual

3. **Opombe:**
Remarks:

/

Ta homologacija se uporablja za tip serijsko izdelanih neoriginalnih izpušnih sistemov za tip motornega kolesa ali njegovih sestavnih delov pod naslednjimi pogoji:

Posamezni proizvodi iz serijske proizvodnje morajo ustrezati najmanj vsem zahtevam Uredbe (EU) št. 168/2013 in Priloge IX k Delegirani uredbi Komisije (EU) št. 134/2014, nazadnje spremenjene z Delegirano uredbo Komisije (EU) št. 2023/2724, "Zahteve za preskus tipa IX: raven hrupa".

Priloženo poročilo o preskusu in risbe so sestavni del te homologacije.

Vsak sestavni del neoriginalnega izpušnega sistema, vendar ne deli in cevi za vgradnjo, mora biti čitljivo in trajno označen z:

- znamko (tovarniškim imenom proizvajalca),
- trgovskim imenom,
- homologacijsko oznako.

Temu tipu proizvoda se dodeli naslednja homologacijska oznaka:

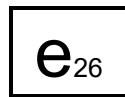

08224G

Homologacijska oznaka na proizvodu mora po izvedbi in velikosti ustrezati zahtevam Izvedbene uredbe Komisije (EU) št. 901/2014, nazadnje spremenjene z Izvedbeno uredbo Komisije (EU) št. 2023/2724.

S tem homologacijskim znakom so lahko označeni samo tisti proizvodi, ki v celoti ustrezajo homologacijski dokumentaciji.

Oznaka EU-homologacije samostojne tehnične enote ali sestavnega dela mora biti na samostojni tehnični enoti ali sestavnem dele nameščena tako, da je neizbrisna (npr. odtisnjena, jedkana, lasersko vgravirana, samouničljiva nalepka), jasno berljiva in vidna na mestu, kjer se namesti na vozilo, ne da bi bilo treba kateri koli del odstraniti z orodjem.

Proizvod je lahko označen tudi s tujo homologacijsko ali drugo oznako, če s tem ni motena razpoznavnost in čitljivost homologacijske oznake, ki jo je dodelil slovenski homologacijski organ.

Na proizvodu ne sme biti oznak, ki bi lahko privedle do zamenjave z uradno dodeljeno oznako.

Kakršnekoli spremembe na proizvodu so dovoljene samo na podlagi posebnega dovoljenja homologacijskega organa.

Veljavnost homologacije preneha z vrnitvijo ali z odvzemom. Homologacija se odvzame, če pogoji za podelitev in obstoj homologacije ne obstajajo več, če lastnik homologacije krši obveznosti, povezane s homologacijo, oziroma če se ugotovi, da homologirani proizvod ne ustreza več veljavnim predpisom.

Proizvajalec je dolžan stalno kontrolirati kakovost homologiranega proizvoda in njegovo skladnost s homologacijsko dokumentacijo. O tej kontroli je dolžan voditi evidenco in omogočiti vpogled v zapiske nadzornemu organu, ki ga določi homologacijski organ. V primeru ugotovitve neskladnosti s homologacijsko dokumentacijo je proizvajalec dolžan o tem takoj obvestiti homologacijski organ.

Homologacijski organ lahko kadarkoli preverja pravilno izvajanje pooblastil, dodeljenih s to homologacijo, in v ta namen tudi izbira vzorce za ponovni preskus. Stroške takšnih pregledov in presoj skladnosti proizvodnje, se zaračunajo proizvajalcu.

Vsako spremembo oznake proizvajalca, naslova ali proizvodne tovarne oziroma pri homologaciji imenovane pooblaščenice je treba takoj sporočiti homologacijskemu organu.

Pravice, podeljene s to homologacijo, so neprenosljive. Pravice tretjih s to homologacijo niso prizadete.

V primerih, da se proizvodnja ali prodaja proizvoda ne začne v roku enega leta od podelitve homologacije, da se proizvodnja ali prodaja prekine za več kot eno leto oziroma, da se predvideva taka prekinitve, je o tem treba takoj obvestiti homologacijski organ.

O začetku proizvodnje ali začetku prodaje oziroma njihovem ponovnem začetku je treba obvestiti homologacijski organ najkasneje v enem mesecu.

Neupoštevanje zgoraj navedenih določil lahko povzroči odvzem homologacije in se kazensko preganja.

Pravno razlago v zvezi s to homologacijo lahko daje samo homologacijski organ.

06.10.2025

mag. Tomaž Svetina, univ.dipl.inž.
vodja sektorja za vozila

This Approval shall apply to non-original exhaust systems for a type of motorcycle or its components from serial production under the following conditions:

Individual products from serial production shall comply at least with all requirements set out in the Regulation (EU) No 168/2013 and Annex(es) IX to Commission Delegated Regulation (EU) No 134/2014, as last amended by Commission Delegated Regulation (EU) No 2023/2724, "Test type IX requirements: sound level".

The attached test report and drawings shall be a constituent part of this Approval.

Each component of the nonoriginal exhaust system, excluding pipes and fitting accessories, shall be marked with a readable and durable:

- *make (trade name of manufacturer),*
- *commercial name,*
- *approval marking.*

This type of product shall be allotted the following approval marking:

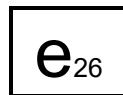

08224G

The design and size of the approval marking shall meet the requirements of the Commission implementing Regulation (EU) No 901/2014, as last amended by Commission implementing Regulation (EU) No 2023/2724.

Only products which comply with the approval documentation may bear the approval marking.

The EU separate technical unit or component type-approval mark shall be affixed to the separate technical unit or component in a way which is indelible (e.g. stamped, etched, laser-engraved, self-destructing adhesive label), clearly legible and visible in the place at which it is to be fitted to the vehicle without the need to remove any parts with the use of tools.

The product may also be marked with a foreign approval or other marking, provided that the identifiability and readability of the approval marking granted by the Slovenian Type Approval Authority is not affected.

The product shall not bear any markings that may lead to confusion with the officially allotted marking.

Changes of any kind performed on the product shall be subject to special permission by the Slovenian Type Approval Authority.

The Approval will become ineffective when returned or withdrawn. The Approval shall be withdrawn: should the conditions for its granting and existence no longer exist, should the owner of the Approval break his obligations related to the Approval, or when it has been established that the approved product no longer complies with the applicable regulations.

The manufacturer shall regularly inspect the quality of the approved product as well as its conformity with the approval documentation. He shall keep record of this inspection and allow to the surveillance body appointed by the Slovenian Type Approval Authority access to the records. Should any non-conformities be found with respect to the approval documentation, the manufacturer shall immediately inform thereof the Slovenian Type Approval Authority.

Any time, the Slovenian Type Approval Authority may check the correct implementation of the authorizations appointed through this Approval, and for this purpose also select samples for a repeated

test. The costs of such checks and conformity of production assessments are charged to the manufacturer.

Any changes regarding the manufacturer's marking, the address or the production plant, or the authorized person appointed through this Approval, shall be forthwith notified to the Slovenian Type Approval Authority.

The rights granted through this Approval shall be untransferrable. The rights of third persons shall not be affected through this Approval.

In the case where the production or sale of the product does not start within one year after the granting of the Approval, or the production or sale is interrupted for a period longer than one year, or such interruption is foreseen, the Slovenian Type Approval Authority shall be immediately notified.

The Slovenian Type Approval Authority shall be notified of the start of production or start of sale, or its restart, within a month's time at the latest.

Non-compliance with above stated provisions may result in withdrawal of the Approval and will be prosecuted.

Legal explanations in relation with this Approval may only be given by the Slovenian Type Approval Authority.

06.10.2025

Tomaž Svetina, M.Sc.Eng.
Head of Vehicle department

**SLOVENIAN TRAFFIC SAFETY AGENCY,
KOTNIKOVA ULICA 19a,
1000 LJUBLJANA,
SLOVENIA**

We, Akrapovič d.d., Malo Hudo 8a. 1295 Ivančna Gorica, Slovenia hereby ask STSA to grant approval against **134/2014*2023/2724 EC (G)** for the following product:
Exhaust system for Motorcycles - muffler:

Type: **M-HHA002**

Version: **M-HHA002 05T (Ti / Ti / Ca)**
M-HHA002 02T (SS / Ti / Ca)
M-HHA002 06T (Ti / Ti / Ti)
M-HHA002 03T (SS / Ti / Ti)
M-HHA002 05TBL (Ti / Ti / Ca)
M-HHA002 02TBL (SS / Ti / Ca)
M-HHA002 06TBL (Ti / Ti / Ti)
M-HHA002 03TBL (SS / Ti / Ti)

Manufacturer: **Akrapovič d.d.**
Malo Hudo 8a
1295 Ivančna Gorica
Slovenia

We declare that we have not applied to any other Approval Authority in the EU Member States for this approval.

We have requested **TÜV SÜD Auto Service GmbH**, to carry out all testing required by the directive and/or regulation that the approval is sought against and to present the entire documentation for the approval.

Yours sincerely,

Date: 20.11.2024

Akrapovič d.d.
Davorin Dobočnik, CEO





**JAVNA AGENCIJA
REPUBLIKE SLOVENIJE
ZA VARNOST PROMETA**

Sektor za vozila

Kotnikova 19a
1000 Ljubljana
Slovenija
telefon: 01 478 89 61
telefaks: 01 478 89 68
<http://www.avp-rs.si>

Številka: 37141-070/2024/03

Datum: 29.07.2025

AKRAPOVIČ D.D.
REGULATORY DEPARTMENT
g./ga. MARKO ŠTAMCAR
MALO HUDO 8A
1295 IVANČNA GORICA
Slovenija

Zadeva: Rezervacija homologacijske številke

Spoštovani!

Sporočamo Vam rezervirano homologacijsko številko za:

Znamka: AKRAPOVIČ
Tip: M-HHA002
Opis: STE: NAPRAVA ZA ZMANJŠEVANJE HRUPA 134/2014G
Direktiva / pravilnik: 2023/2724/EU - Delegirana uredba Komisije (EU) 2023/2724 z dne 27. septembra 2023 o spremembi in popravku Delegirane uredbe (EU) št. 134/2014 glede nekaterih sklicevanj na pravilnike Ekonomske komisije Združenih narodov za Evropo (UN/ECE) in razpoložljivosti nekaterih čistih plinov

REZERVACIJA: e26*2023/2724*08224*00

PRI ORIGINALNI VLOGI OBVEZNO NAVESTI, DA GRE ZA DOPOLNITEV VLOGE: 37141-070/2024/03

Lep pozdrav!

Poslano:
- AKRAPOVIČ D.D.



Digitally signed
by JOŽE TRŠELIČ
Date:
2025.10.06
08:37:51 +02'00'

PRÜFBERICHT TEST REPORT

Nr. / no. 25-00067-CM-GBM-00

über die Prüfung zur Bauartgenehmigung einer Nicht-Originalauspuffanlage oder
von Einzelteilen hiervon als selbstständige technische Einheit für Krafträder /

*about a test regarding a component type-approval for non-original exhaust system or
components thereof, as a technical unit for motorcycles*

Verordnung / Regulation (EU) 134/2014 vom / dated 16.12.2013
zuletzt geändert / last amended (EU) 2023/2724 vom / dated 27.09.2023
Kodierung / Codification G

zur Ergänzung der Verordnung (EU) Nr. 168/2013 des Europäischen Parlaments
und des Rates. /
supplementing Regulation (EU) 168/2013 of the European Parliament and the Council.

Genehmigungsstand / Approval status	
<input checked="" type="checkbox"/>	Erteilung einer Typgenehmigung <i>Granting of a type approval</i> e26*134/2014*2023/2724G*08224*00
<input type="checkbox"/>	Nachtrag/Änderung zur Typgenehmigung Nr. <i>Extension/correction to type approval no.</i>

Gründe der Erweiterung / Reasons for extension

Es wird geändert /
It will be changed: -

Es kommt hinzu /
It will be added: -

Es wird aktualisiert /
It will be updated: -



0. Allgemeine Angaben / General information

0.1. Fabrikmarke / Make: AKRAPOVIČ

0.2. Typ / Type: M-HHA002

0.2.1. Ausführungen / Variants:

Ausführungen / Variants	Material / Material		
	Rohre / Tubes	Außenmantel / Sleeve	Endkappe / End cap
M-HHA002 05T	Titan / Titan	Titan / Titan	Karbon / Carbon
M-HHA002 02T	VA / Stainless steel	Titan / Titan	Karbon / Carbon
M-HHA002 06T	Titan / Titan	Titan / Titan	Titan / Titan
M-HHA002 03T	VA / Stainless steel	Titan / Titan	Titan / Titan
M-HHA002 05TBL	Titan / Titan	Titan / Titan	Karbon / Carbon
M-HHA002 02TBL	VA / Stainless steel	Titan / Titan	Karbon / Carbon
M-HHA002 06TBL	Titan / Titan	Titan / Titan	Titan / Titan
M-HHA002 03TBL	VA / Stainless steel	Titan / Titan	Titan / Titan

Die Ausführungen unterscheiden sich in der Verwendung verschiedener Werkstoffe. Der konstruktive Aufbau ist gleich. Das akustische Verhalten ist als gleichwertig zu betrachten. /

The variants vary because different materials are used. The basic construction remains the same. The acoustic behaviour is to be regarded as equivalent.

0.3. Name und Anschrift des Herstellers /
 Name and address of manufacturer: Akrapovič d.d.
 Malo Hudo 8a
 SLO-1295 Ivančna Gorica

0.4. Name und Anschrift des Beauftragten /
 Name and address of authorized agent: entfällt / n.a.

0.5. Nr. des Beschreibungsbogens /
 No. of information document: M-HHA002
 Ausgabedatum / Date: 08.09.2025

1. Verwendungsbereich / Application range

- 1.1. Klasse der Fahrzeuge für die die Anlage bestimmt ist /
Class of the vehicles the unit is used for: L3e
- 1.2. Beschreibung der Fahrzeuge für die die Einrichtung bestimmt ist /
Description of the vehicles the unit is used for: siehe Anlage 2 / see enclosure 2

2. Angaben zum Prüfobjekt / Composition of the separate technical unit

- 2.1. Art der Technischen Einheit / *Kind of technical unit:*
Technische Einheit, bestehend aus einem Schalldämpfer nach Zeichnung Nr. 133249-HOM, oval 126,8 x 201,8 x 420 mm, Absorptionsprinzip mit Eintritts- und Austrittsrohren gem. Anlage 1. / *Technical unit, consisting of a silencer according to drawing no. 133249-HOM, oval 126,8 x 201,8 x 420 mm, absorption-principle with inlet and outlet pipes according to enclosure 1.*
- 2.2. Ort der Kennzeichnung /
Place of marking: Lasergravur, Typschild aufgenietet /
Engraved by laser, plate fixed with rivets
- 2.3. Zusammenstellung der techn. Einheit /
Composition of the separate technical unit: siehe Anlage 1 / see enclosure 1
- 2.4. Lage und Richtung der Auspuffmündung /
Position and direction of the tail pipe: rechts seitlich nach hinten /
right side to the rear

3. Prüfprotokoll / Test report

Die Prüfungen wurden in 2 Versuchsreihen A und B mit folgenden Fahrzeugen durchgeführt. /

The tests were carried out in 2 series A and B with following vehicles:

Versuchsreihe A / Series A: (Ifd. Nr. / *no.* 3, Messdatum / *Date* 01.09.2025)

3.1. Fahrzeug / *Vehicle*

3.1.1. Typ / <i>Type:</i>	KTM V2 Adventure
3.1.1.1 Variante / <i>Version / Variant / Version:</i>	C1 / -
3.1.1.2 Fahrzeugkategorie / <i>Category:</i>	L3e-A3
3.1.1.3 Handelsbezeichnung / <i>Model:</i>	KTM 1290 Super Adventure R
3.1.2. Hersteller / <i>Manufacturer:</i>	KTM AG Stallhofnerstr. 3 A-5230 Mattighofen
3.1.3. Genehmigungs-Nr. / <i>Homologation no.:</i>	e1*168/2013*00274*
3.1.3.1 Nachtrag bzw. Erweiterung / <i>Extension:</i>	00
3.1.4. Fahrzeugidentifizierungsnummer / <i>Vehicle identification no.:</i>	VBKV59403PM977026
3.1.5. Baujahr / <i>Year of manufacture:</i>	2024
3.1.6. Km-Stand / <i>Kilometers:</i>	9743
3.1.7. Zul. Gesamtgewicht / <i>Total weight:</i>	450 kg

3.2. Antriebsmaschine / *Engine*

3.2.1. Hersteller / <i>Manufacturer:</i>	KTM
3.2.2. Typ / <i>Type:</i>	619
3.2.3. Hubraum / <i>Engine capacity:</i>	1301 cm ³
3.2.4. Höchstleistung / <i>Max. net power:</i>	118 kW bei / <i>at</i> 9000 min ⁻¹
3.2.5. Max. Drehmoment / <i>Max. net torque:</i>	138 Nm bei / <i>at</i> 6500 min ⁻¹

3. **Prüfprotokoll** (Fortsetzung) / **Test report** (continuation)

3.3. **Kraftübertragung / Transmission**

- 3.3.1. Art der Kraftübertragung /
Kind of transmission: mechanisch / *mechanical*
- 3.3.2. Getriebe / *Gearbox:* 6-Gang-manuell / *6-gear-manual*
- 3.3.3. Übersetzungsverhältnisse /
Transmission ratios
primär / *primary* / sekundär / *secondary:* 1,900 / 2,471
- Höchstgeschwindigkeit / *Top speed:* 235 km/h
- Reifen / *Tires:* Bridgestone Battlax Adventure
Achse / *Axle 1:* 90/90-21 M/C 54V
Achse / *Axle 2:* 150/70 R18 M/C 70V

3.4. **Zusammenbau der Auspuffanlage / Assembly of the exhaust system** (Teile lfd. Nr. lt. Anlage 1 / *no. of parts acc. enclosure 1*)

Versuchsreihe A / *Series A:* 1)2a)

3.5. **Messung der Geräuschwerte / Acoustic measurements**

- 3.5.1. Hersteller des Messgerätes /
Manufacturer of test equipment: MÜLLER-BBM
- 3.5.2. Typ des Messgerätes /
Type of the test equipment: PAK MK II Configuration
- 3.5.3. Fahrgeräusch, Standgeräusch /
Drive by noise, stationary noise: nach ECE-R 41.05 /
according ECE-R 41.05
- 3.5.3.1 Position des Mikrofons /
Position of the microphone: gemäß UN-R41 Anhang 3 Anlage 2,
rechte Fahrzeugseite /
acc. to UN-R41 Annex 3 Appendix 2,
right side of the vehicle
- 3.5.4. Beladungszustand bei der Fahr-
geräuschmessung /
Load condition during drive by test: Leergewicht zuzüglich 75 kg Fahrer /
Unloaded weight plus 75 kg driver
- 3.5.5. Abweichung bei Kalibrierung /
Deviation at calibration: < 0.2 dB(A)

3. **Prüfprotokoll** (Fortsetzung) / **Test report** (continuation)

3.6. **Messung der Leistung / Power measurement**

3.6.1. Messung der Leistungskurve mit Nicht-Originalauspuffanlage / *Testing of max. power with non-original exhaust system:*

Die gemessene Nennleistung und die zugehörige Drehzahl liegen im Toleranzbereich von 5% im Vergleich zu den mit der Originalauspuffanlage gemessenen Werten (siehe Anlage). /

The tested max. power und the engine speed is in the 5% tolerance in comparison with the original exhaust system (see enclosure).

3.6.2. Messung der Höchstgeschwindigkeit mit Nicht-Originalauspuffanlage / *Testing of top speed with non-original exhaust system:*

entfällt, da Fahrzeugklasse /
not applicable, because vehicle class: L3e

Versuchsreihe B / Series B: (Ifd. Nr. / no. 5, Messdatum / Date 19.11.2024)

3.1. **Fahrzeug / Vehicle**

3.1.2. Typ / Type:	KTM V2 ADV
3.1.1.1 Variante / Version / Variant / Version:	B / -
3.1.1.2 Fahrzeugklasse / Category:	L3e-A3
3.1.1.3 Handelsbezeichnung / Model:	KTM 1390 Super Adventure S EVO
3.1.2. Hersteller / Manufacturer:	KTM AG Stallhofnerstr. 3 A-5230 Mattighofen
3.1.3. Genehmigungs-Nr. / Homologation no.:	e1*168/2013*00403*
3.1.3.1 Nachtrag bzw. Erweiterung / Extension:	00
3.1.4. Fahrzeugidentifizierungsnummer / Vehicle identification no.:	VBKV79P37SM901589
3.1.5. Baujahr / Year of manufacture:	2024
3.1.6. Km-Stand / Kilometers:	130
3.1.7. Zul. Gesamtgewicht / Total weight:	475 kg

3. **Prüfprotokoll** (Fortsetzung) / **Test report** (continuation)

3.2. **Antriebsmaschine / Engine**

- 3.2.1. Hersteller / *Manufacturer:* KTM
- 3.2.2. Typ / *Type:* A626
- 3.2.3. Hubraum / *Engine capacity:* 1350 cm³
- 3.2.4. Höchstleistung / *Max. net power:* 127 kW bei / *at* 9500 min⁻¹
- 3.2.5. Max. Drehmoment / *Max. net torque:* 145 Nm bei / *at* 8000 min⁻¹

3.3. **Kraftübertragung / Transmission**

- 3.3.1. Art der Kraftübertragung /
Kind of transmission: mechanisch / *mechanical*
- 3.3.2. Getriebe / *Gearbox:* 6-Gang-manuell / *6-gear-manual*
- 3.3.3. Übersetzungsverhältnisse /
Transmission ratios
primär / *primary* / sekundär / *secondary:* 1,900 / 2,471
- Höchstgeschwindigkeit / *Top speed:* 250 km/h
- Reifen / *Tires:* Dunlop Trailmax Meridian
- Achse / *Axle 1:* 120/70 ZR19 60W
- Achse / *Axle 2:* 170/60 ZR17 72W

3.4. **Zusammenbau der Auspuffanlage / Assembly of the exhaust system** (Teile lfd. Nr. lt. Anlage 1 / *no. of parts acc. enclosure 1*)

- Versuchsreihe B / *Series B:* 1)2a)

3.5. **Messung der Geräuschwerte / Acoustic measurements**

- 3.5.1. Hersteller des Messgerätes /
Manufacturer of test equipment: MÜLLER-BBM
- 3.5.2. Typ des Messgerätes /
Type of the test equipment: PAK MK II Configuration

3. **Prüfprotokoll** (Fortsetzung) / **Test report** (continuation)

- 3.5.3. Fahrgeräusch, Standgeräusch /
Drive by noise, stationary noise: nach ECE-R 41.05 /
according ECE-R 41.05
- 3.5.3.1 Position des Mikrofons /
Position of the microphone: gemäß UN-R41 Anhang 3 Anlage 2,
rechte Fahrzeugseite /
acc. to UN-R41 Annex 3 Appendix 2,
right side of the vehicle
- 3.5.4. Beladungszustand bei der Fahr-
geräuschmessung /
Load condition during drive by test: Leergewicht zuzüglich 75 kg Fahrer /
Unloaded weight plus 75 kg driver
- 3.5.5. Abweichung bei Kalibrierung /
Deviation at calibration: < 0.2 dB(A)

3.6. **Messung der Leistung / Power measurement**

- 3.6.1. Messung der Leistungskurve mit Nicht-Originalauspuffanlage /
Testing of max. power with non-original exhaust system:

Die gemessene Nennleistung und die zugehörige Drehzahl liegen im Toleranzbereich von 5% im Vergleich zu den mit der Originalauspuffanlage gemessenen Werten (siehe Anlage). /

The tested max. power and the engine speed is in the 5% tolerance in comparison with the original exhaust system (see enclosure).

- 3.6.2. Messung der Höchstgeschwindigkeit mit Nicht-Originalauspuffanlage /
Testing of top speed with non-original exhaust system:

entfällt, da Fahrzeugklasse /
not applicable, because vehicle class: L3e

3.7. **Konditionierung der Auspuffschalldämpferanlage /** **Conditioning of silencer system**

durch Druckschwingungen / *by pulsation*

3. **Prüfprotokoll** (Fortsetzung) / **Test report** (continuation)

3.8. **Ergebnisse / Test results**

Die Ergebnisse der Prüfungen hinsichtlich / *The test results of*

- 3.8.1. Geräuschmessung / *Noise testing*
- 3.8.2. Leistungsmessung / *Power measurement*

sind der als Anlage beigefügten Tabellen zu entnehmen. /
are attached in the enclosures.

Aufgrund der Messung mit dem/n o.g. Fahrzeug/en können auch die in Anlage 2 aufgeführten Krafräder, die die gleiche bzw. akustisch gleichwertige Serien-Auspuffanlage besitzen und gleiche bzw. geringere Motorleistung haben, mit in den Verwendungsbereich aufgenommen werden. /
All motorcycles with the same or acoustically equivalent serial exhaust system and same or less performance mentioned in enclosure 2 can be taken into the field of application due to the measurement with the above-named motorcycle/s.

- 3.8.3. Die beschriebene Nicht-Originalauspuffanlage / Technische Einheit darf an den in der Anlage 2 aufgeführten Kraftfahrzeugen unter den dort genannten Bedingungen verwendet werden. /
The described non-original exhaust system / technical unit is suitable for an application at the vehicles listed in enclosure 2.
- 3.8.4. Die allgemeinen Spezifikationen gemäß:
(EU) 134/2014; Anhang IX; Anlage 2; Abschnitt 3.5.1. werden durch die Nicht-Originalauspuffanlage als technische Einheit erfüllt. /
*The general specifications regarding:
(EU) 134/2014; Annex IX; Appendix 2; Clause 3.5.1. are fulfilled by the non-original exhaust system as technical unit.*

4. **Anlagen / Enclosures**

- Anlage 1: Teile der technischen Einheit (1 Seite / Page)
Enclosure 1: Composition of the separate technical unit
- Anlage 2: Verwendungsbereich (1 Seite / Page)
Enclosure 2: Field of application
- Anlage 3: Ergebnisse der Prüfungen (8 Seiten / Pages)
Enclosure 3: Test results



5. Schlussbescheinigung / Summary

Das beschriebene Prüfobjekt entspricht der genannten Prüfspezifikation. Das Prüfobjekt wurde als ungünstigster Fall entsprechend der Prozessbeschreibung "Anforderungen an Prüfberichte (AS-PB-T-02)" aus der Beschreibung des Typs (Beschreibungsmappe) ausgewählt. Somit erfüllt auch der beschriebene Typ die o. a. Prüfspezifikation.

In Bezug auf die Einhaltung der Grenzwerte wurde die Messunsicherheit nicht berücksichtigt.

Der Hersteller trägt die Verantwortung für die zu Verfügung gestellten Informationen und Prüfmuster. Die Prüfergebnisse beziehen sich auf die erhaltenen und genannten Prüfmuster. Diese sind repräsentativ für den beschriebenen Typ.

Der Prüfbericht darf nur vom Auftraggeber und nur in vollem Wortlaut vervielfältigt und weitergegeben werden. Eine auszugsweise Vervielfältigung und Veröffentlichung des Prüfberichtes sind nur nach schriftlicher Genehmigung zulässig. /

The test object described conforms to the mentioned test specification. The worst-case configuration was selected from the type of description (information folder) in accordance with the process description "Requirements for Test Reports (AS-PB-T-02)". Thus, the described type conforms to the test specification.

In question of meeting the limits the measurement uncertainty was ignored.

The manufacturer is responsible for the information and the test specimens provided by him. The test results relate only to the test specimens as received and mentioned. The test specimens are representative for the type described.

The test report may be reproduced and published in full and by the client only. It can be reproduced partially with the written permission of the test laboratory only.



5. Schlussbescheinigung (Fortsetzung) / Summary (continuation)

TÜV SÜD Auto Service GmbH ist benannt als Technischer Dienst durch:
TÜV SÜD Auto Service GmbH is designated as Technical Service by:

Genehmigungsbehörde <i>Approval authority</i>	Land <i>Country</i>	Registriernummer <i>Registration number</i>
Kraftfahrt-Bundesamt (KBA)	Deutschland <i>Germany</i>	KBA-P 00100-10
Vehicle Certification Agency (VCA)	Vereinigtes Königreich <i>United Kingdom</i>	VCA-TS-006
Approval Authority of the Netherlands (RDW)	Niederlande <i>The Netherlands</i>	RDWT-082-xx
National Standards Authority of Ireland (NSAI)	Irland <i>Ireland</i>	49
Swedish Transport Agency (STA)	Schweden <i>Sweden</i>	TT 0024
Société Nationale de Certification et d'Homologation s.a.	Luxemburg <i>Luxembourg</i>	13/B(g)
Vehicle Safety Certification Center (VSCC)	Taiwan <i>Taiwan</i>	DE04-06-2

Dieser Bericht umfasst Seite 1 bis 11. /
This test report contains the pages 1 up to 11.

München, 08.09.2025

F. Rinske (B. Eng.)
Sachverständiger / *Recognized Expert*
fr
M-HHA002_EC_0.docx





Prüfbericht Nr. / Test report No.: 25-00067-CM-GBM-00
Hersteller / Manufacturer: Akrapovič, d.d., SLO-1295 Ivancna Gorica
Typ / Type: M-HHA002

ANLAGE 1 ENCLOSURE 1

Teile der technischen Einheit / Composition of the separate technical unit

Lfd. Nr. / No.	Einzelteile, Abmessungen in mm / Components parts, dimensions in mm	Abmessungen des Teiles in mm bzw. Originalteil / Ersatzteil / Dimensions of the part in mm or original part / replacement part	Teilenummer bzw. Genehmigungsnummer / Part no. or homologation no.
1)	Krümmerröhre mit Katalysator / Header pipes with catalytic converter	Originalteile / Original parts	-
2a)	Schalldämpfer / Silencer (Eintrittsrohr / Inlet pipe Ø 88 2 Austrittsrohre / Outlet pipes Ø 28 / 32)	oval 126,8 x 201,8 Länge ohne Endkappe / Length without end cap 420	M-HHA002 e26*08224*G E26 92R-02 8224

M-HHA002_EC_1.docx



Prüfbericht Nr. / Test report No.: 25-00067-CM-GBM-00
 Hersteller / Manufacturer: Akrapovič, d.d., SLO-1295 Ivanačna Gorica
 Typ / Type: M-HHA002

ANLAGE 2 ENCLOSURE 2

Verwendungsbereich / Field of application

Die Fahrzeuge erfüllen - bezugnehmend auf ihre Fahrzeugtypgenehmigung - die Umweltafordnerungsstufen:
The vehicles fulfill - regarding their Whole Vehicle Type Approval (WVTA) - the environmental steps:

Euro (5/5+)
 Euro (5/5+)

Lfd. Nr.	Hersteller	Fabrikmarke	Handelsbezeichnung	Fahrzeugtyp ab Genehmigung Nr.	Var. Vers.	Motor typ 4-Takt	Hubraum in cm ³	Nennleistung kW/min ⁻¹	Sonstige bestimmende Merkmale	Anordnung entspr. Anl. 1 lfd. Nr.
No. of vehicle	Manufacturer	Trade mark	Commercial description	Vehicle type beginning with no. of homologation	Var. Vers.	Engine type 4-Stroke	Engine capacity in cm ³	max. engine power kW/min ⁻¹	Additional remarks	Composition reg. enclosure no. 1
1)	KTM (A)	KTM	KTM 1290 Super Adventure	KTM V2 Adventure e1*168/2013*00274*	A1 / -	619	1301	118/9000	mit Kat. / with cat. *)	1)2a)
2)			KTM 1290 Super Adventure S		B1 / -					
3)			KTM 1290 Super Adventure R		C1 / -					
4)			KTM 1390 Super Adventure S	KTM V2 ADV e1*168/2013*00403*	A / -	A626	1350	127/9500		
5)			KTM 1390 Super Adventure S EVO		B / -					
6)			KTM 1390 Super Adventure R		C / -					

*) Der serienmäßige Katalysator bleibt unverändert im Abgassystem. Eine Verschlechterung des Abgasverhaltens ist nicht zu erwarten. /
The original catalytic converter remains in the exhaust system. A degradation of catalyst efficiency is not expected.

M-HHA002_EC_2.docx



Prüfbericht Nr. / Test report No.: 25-00067-CM-GBM-00
 Hersteller / Manufacturer: Akrapovič, d.d., SLO-1295 Ivancna Gorica
 Typ / Type: M-HHA002

ANLAGE 3 ENCLOSURE 3

Ergebnisse der Geräusch- und Leistungsmessungen – Versuchsreihe A / Results of noise testing and power measurements – Series A

Lfd. Nr. Fahrzeug	Leistung		Leistung Austausch kW/min ⁻¹	V _{max}		Fahrgeräusch in dB(A) / Sound level driving vehicle in dB(A) ²⁾				Standgeräusch in dB(A) / Sound level stationary vehicle in dB(A) ²⁾			
	Serie kW/min ⁻¹	V _{max} Serie km/h		V _{max} Aus- tausch km/h	gemessen in Gang	Grenz- wert ¹⁾	Serie gemes- sen	Austausch gemessen	bei km/h	lt. Fzg. BE	Serie gemes- sen	Austausch gemessen	bei min ⁻¹
No. of vehicle	Engine power original kW/min ⁻¹	V _{max} original km/h	V _{max} non original km/h	measured in gear ratio	Limit value ¹⁾	original/ mea- sured L _{Urban}	non- original measured L _{Urban}	at km/h	Vehicle type hom.	original mea- sured	non- original measured	at min ⁻¹	
3) A:	118/9000	-	-	4	77	77,6	77,6	50	89	91	91	4500	

¹⁾ Grenzwert der Richtlinienfassung, die bei Erteilung der Fahrzeuggenehmigung Gültigkeit hatte. /
 Limit value of directive which was valid by vehicle type homologation.

²⁾ Betriebsart / Operating mode: Rally



Prüfbericht Nr. / Test report No.: 25-00067-CM-GBM-00
Hersteller / Manufacturer: Akrapovič, d.d., SLO-1295 Ivanačna Gorica
Typ / Type: M-HHA002

ANLAGE 3 ENCLOSURE 3

Prüfbedingungen / Test conditions

Masse im fahrbereiten Zustand / Vehicle kerb weight	m_{kerb} in kg	240
Testgewicht / Test weight	m_t in kg	315
Fahrzeug- bzw. Bezugslänge / Length of vehicle / reference	l_{veh} / l_{ref} in m	2,25
Leistungsgewicht / Power to mass ratio	PMR in kW/t	374,6
Referenzbeschleunigung / Reference acceleration	$a_{wot\ ref}$ in m/s^2	4,41
Sollbeschleunigung / Target acceleration	a_{urban} in m/s^2	2,10
Länge Vorbeschleunigung / Length of pre-acceleration	l_{pa} in m	0
Benutzter Gang / Tested gear	-	4
Teillastfaktor / Partial load factor	k_p	0,492 / 0,510
Ganggewichtungsfaktor / Gear weight factor	k	-

ANLAGE 3 ENCLOSURE 3

Ergebnis der Prüfungen – Seriensystem – Versuchsreihe A / Test results - Original system – Series A

Messungen und Berechnung der Vorbeifahrtmessung / Tests and calculation passby noise level

Gang / Stufe / Gear / Position	Beschl. Vorbeifahrt / Accel. driving noise level			Konstante Vorbeifahrt / Constant driving noise level				
	w _{otest} (l) links / left dB(A)	rechts / right dB(A)	a _{wotest} (l) m/s ²	V P,P' km/h	cr _{test} (l) links / left dB(A)	rechts / right dB(A)	a _{act test} (l)	V P,P' km/h
4	83,0	81,9	4,32	49,9	72,4	71,0	-	49,4
4	83,0	81,5	4,30	49,7	72,9	71,8	-	49,4
4	83,0	81,4	4,25	49,0	71,9	72,0	-	50,0

Vorbeifahrtmessung Endergebnis / Passby noise level final result

L _{wot rep} dB(A)	83,0	L _{ors rep} dB(A)	72,4
L _{urban} dB(A)	77,6	Grenzwert / Limit value dB(A)	77

Standgeräusch / Stationary noise level

n = 4500 min ⁻¹	links / left dB(A)	rechts / right dB(A)	links / left dB(A)	rechts / right dB(A)	links / left dB(A)	rechts / right dB(A)
Test 1	-	91,3	-	91,0	-	91,0
Test 2	-	90,5	-	90,9	-	91,0
Test 3	-	91,0	-	90,9	-	90,8
Mode	Rally					
Ergebnis / Result	91					
n = 4500 min ⁻¹	links / left dB(A)	rechts / right dB(A)	links / left dB(A)	rechts / right dB(A)	Sport	
Test 1	-	91,0	-	91,2	91	
Test 2	-	91,5	-	91,3	91	
Test 3	-	91,7	-	91,3	91	
Mode	Offroad					
Ergebnis / Result	91					
	Street					
	91					

ANLAGE 3 ENCLOSURE 3

Ergebnis der Prüfungen - Austauschsystem – Versuchsreihe A / Test results - Replacement system – Series A

Messungen und Berechnung der Vorbeifahrtmessung / Tests and calculation passby noise level

Gang / Stufe / Gear / Position	Beschl. Vorbeifahrt / Accel. driving noise level			Konstante Vorbeifahrt / Constant driving noise level			
	w _{otest} (l) links / left dB(A)	rechts / right dB(A)	a _{wotest} (l) m/s ²	cr _{test} (l) links / left dB(A)	rechts / right dB(A)	a _{act test} (l)	V P,P' km/h
4	82,4	82,6	4,17	72,4	72,1	-	49,2
4	82,4	82,8	4,14	72,2	72,2	-	49,2
4	82,3	82,7	4,07	72,7	71,8	-	49,4

Vorbeifahrtmessung Endergebnis / Passby noise level final result

L _{wot rep} dB(A)	82,7	L _{ors rep} dB(A)	72,4
L _{urban} dB(A)	77,6	Grenzwert / Limit value dB(A)	77

Standgeräusch / Stationary noise level

n = 4500 min ⁻¹	links / left dB(A)	rechts / right dB(A)	links / left dB(A)	rechts / right dB(A)	links / left dB(A)	rechts / right dB(A)
Test 1	-	91,0	-	90,6	-	90,6
Test 2	-	90,7	-	90,5	-	90,6
Test 3	-	91,3	-	90,3	-	91,0
Mode	Rally					
Ergebnis / Result	91		91		Street	
n = 4500 min ⁻¹	links / left dB(A)	rechts / right dB(A)	links / left dB(A)	rechts / right dB(A)		
Test 1	-	90,7	-	90,4		
Test 2	-	90,6	-	90,5		
Test 3	-	90,6	-	90,0		
Mode	Offroad					
Ergebnis / Result	91		90			



Prüfbericht Nr. / Test report No.: 25-00067-CM-GBM-00
 Hersteller / Manufacturer: Akrapovič, d.d., SLO-1295 Ivancna Gorica
 Typ / Type: M-HHA002

ANLAGE 3 ENCLOSURE 3

Ergebnisse der Geräusch- und Leistungsmessungen – Versuchsreihe B / Results of noise testing and power measurements – Series B

Lfd. Nr. Fahrzeug	Leistung		Leistung Austausch kW/min ⁻¹	V _{max} Serie km/h	V _{max} Aus- tausch km/h	Fahrgeräusch in dB(A) / Sound level driving vehicle in dB(A) ²⁾			Standgeräusch in dB(A) / Sound level stationary vehicle in dB(A) ²⁾					
	Serie kW/min ⁻¹	Engine power original kW/min ⁻¹				Grenz- wert ¹⁾	Serie gemes- sen	Austausch gemessen	bei km/h	It. Fzg. BE	Serie gemes- sen	Austausch gemessen	bei min ⁻¹	
No. of vehicle	Engine power original kW/min ⁻¹	Engine power non-original kW/min ⁻¹	Limit value ¹⁾	V _{max} original km/h	V _{max} non original km/h	measured in gear ratio	SL _{EU5}	original/ mea- sured L _{Urban}	non- original measured L _{Urban}	at km/h	Vehicle type hom.	original mea- sured	non- original measured	at min ⁻¹
5) B:	127/9500	127/9500	77	-	-	4	77	76,5 L _{Urban}	76,9 L _{Urban}	50	91	92	91	4750

¹⁾ Grenzwert der Richtlinienfassung, die bei Erteilung der Fahrzeuggenehmigung Gültigkeit hatte. /
 Limit value of directive which was valid by vehicle type homologation.

²⁾ Betriebsart / Operating mode: Sport

Prüfbericht Nr. / Test report No.: 25-00067-CM-GBM-00
 Hersteller / Manufacturer: Akrapovič, d.d., SLO-1295 Ivanačna Gorica
 Typ / Type: M-HHA002

ANLAGE 3 ENCLOSURE 3

Prüfbedingungen / Test conditions

Masse im fahrbereiten Zustand / Vehicle kerb weight	m_{kerb} in kg	260
Testgewicht / Test weight	m_t in kg	335
Fahrzeug- bzw. Bezugslänge / Length of vehicle / reference	l_{veh} / l_{ref} in m	2,35
Leistungsgewicht / Power to mass ratio	PMR in kW/t	379,1
Referenzbeschleunigung / Reference acceleration	$a_{wot\ ref}$ in m/s^2	4,43
Sollbeschleunigung / Target acceleration	a_{urban} in m/s^2	2,11
Länge Vorbeschleunigung / Length of pre-acceleration	l_{pa} in m	0
Benutzter Gang / Tested gear	-	4
Teillastfaktor / Partial load factor	k_p	0,549 / 0,553
Ganggewichtungsfaktor / Gear weight factor	k	-

ANLAGE 3 ENCLOSURE 3

Ergebnis der Prüfungen – Seriensystem – Versuchsreihe B / Test results - Original system – Series B

Messungen und Berechnung der Vorbeifahrtmessung / Tests and calculation passby noise level

Gang / Stufe / Gear / Position	Beschl. Vorbeifahrt / Accel. driving noise level		Konstante Vorbeifahrt / Constant driving noise level		V P,P' km/h
	wot _{test} (l) links / left dB(A)	rechts / right dB(A)	cr _{test} (l) links / left dB(A)	rechts / right dB(A)	
4	80,7	80,2	72,0	72,8	50,6
4	80,3	80,6	71,4	73,1	50,2
4	80,4	80,9	71,0	73,5	50,3

Vorbeifahrtmessung Endergebnis / Passby noise level final result

L _{wot rep} dB(A)	80,6	L _{ors rep} dB(A)	73,1
L _{urban} dB(A)	76,5	Grenzwert / Limit value dB(A)	77

Standgeräusch / Stationary noise level

n = 4750 min ⁻¹	links / left dB(A)		rechts / right dB(A)		links / left dB(A)		rechts / right dB(A)	
Test 1	-	-	91,5	91,6	-	-	91,4	91,4
Test 2	-	-	91,4	91,4	-	-	91,7	91,7
Test 3	-	-	91,6	91,2	-	-	91,6	91,6
Mode	Sport		Rain		Street		Street	
Ergebnis / Result	92		91		92		92	



Prüfbericht Nr. / Test report No.: 25-00067-CM-GBM-00
 Hersteller / Manufacturer: Akrapovič, d.d., SLO-1295 Ivanačna Gorica
 Typ / Type: M-HHA002

ANLAGE 3 ENCLOSURE 3

Ergebnis der Prüfungen - Austauschsystem – Versuchsreihe B / Test results - Replacement system – Series B

Messungen und Berechnung der Vorbeifahrtmessung / Tests and calculation passby noise level

Gang / Stufe / Gear / Position	Beschl. Vorbeifahrt / Accel. driving noise level			Konstante Vorbeifahrt / Constant driving noise level			
	wot _{test} (l) links / left dB(A)	rechts / right dB(A)	a _{wot, test} (l) m/s ²	cr _{test} (l) links / left dB(A)	rechts / right dB(A)	a _{act test} (l)	V P.P. km/h
4	81,9	82,3	4,75	72,3	72,7	-	50,2
4	82,1	82,0	4,55	72,6	72,7	-	49,5
4	82,3	82,3	4,86	72,9	72,4	-	49,5

Vorbeifahrtmessung Endergebnis / Passby noise level final result

L _{wot rep} dB(A)	82,2	L _{ors rep} dB(A)	72,6
L _{urban} dB(A)	76,9	Grenzwert / Limit value dB(A)	77

Standgeräusch / Stationary noise level

n = 4750 min ⁻¹	links / left dB(A)	rechts / right dB(A)	links / left dB(A)	rechts / right dB(A)	links / left dB(A)	rechts / right dB(A)
Test 1	-	91,1	-	91,0	-	90,9
Test 2	-	91,3	-	91,2	-	91,0
Test 3	-	91,1	-	90,6	-	91,0
Mode	Sport					
Ergebnis / Result	91			91		
	Street					

M-HHA002_EC_3.docx

Information Document M-HHA002

relating to EU type-approval of a noise-abatement device as a STU

TÜV SÜD Auto Service Technical Report: 25-00067-CM-GBM-00

Item No.	(Sub) categories	Detailed information
B.		General information concerning systems, components, or separate technical units
0.7.	L1e — L7e	Make(s) (trade name(s) of manufacturer): AKRAPOVIČ
0.8.	L1e — L7e	Type: M-HHA002
0.8.1.	L1e — L7e	Commercial name(s) (if available): n.a.
0.8.2.	L1e — L7e	Type-approval number(s) (if available): e26*134/2014*2023/2724G*08224*00
0.8.3.	L1e — L7e	Type-approval(s) issued on (date, if available): n.a.
0.9.	L1e — L7e	Company name and address of manufacturer: Akrapovic d.d. Malo Hudo 8a SLO-1295 Ivančna Gorica
0.9.1.	L1e — L7e	Name(s) and address(es) of assembly plants: Akrapovič, d.d. Malo Hudo 8a SLO-1295 Ivančna Gorica Akrapovič d.d., PE Ulica heroja Stariha 24 SLO-8340 Črnomelj
0.9.2.	L1e — L7e	Name and address of manufacturer's authorized representative, if any: n.a.
0.10.		Vehicle(s) for which the system/separate technical unit is intended for:
0.10.1.	L1e — L7e	Type: see Technical Report
0.10.2.	L1e — L7e	Variant: see Technical Report
0.10.3.	L1e — L7e	Version: see Technical Report
0.10.4.	L1e — L7e	Commercial name(s) (if available): see Technical Report
0.10.5.	L1e — L7e	Category, subcategory and sub-subcategory of vehicle: see Technical Report
C.		General information concerning vehicle, systems, components, or separate technical units
0.12.		Conformity of production
0.12.1.	L1e — L7e	Controlled by ISO 9001:2008 Quality Management System certified by TÜV SÜD Management Service GmbH Registration no.: 12 100/104 31148 TMS
1.		GENERAL CONSTRUCTION CHARACTERISTICS
1.8.		Propulsion unit performance
1.8.1.	L3e, L4e, L5e, L7e-A, L7e-B2	Declared maximum vehicle speed: km/h see Technical Report
1.8.2.	L1e, L2e, L6e, L7e-B1, L7e-C	Maximum design vehicle speed: and gear in which it is reached: n.a.
1.8.3.	L1e — L7e	Maximum net power combustion engine: . kW at . min ⁻¹ at A/F ratio: see Technical Report
1.8.4.	L1e — L7e	Maximum net torque combustion engine: . Nm at . min ⁻¹ at A/F ratio: see Technical Report
1.8.5.	L1e — L7e	Maximum continuous-rated power electric motor (15/30 minutes power): n.a.
1.8.6.	L1e — L7e	Maximum continuous-rated torque electric motor: Nm at min ⁻¹ n.a.
1.8.7.	L1e — L7e	Maximum continuous total power for propulsion(s): kW. at min ⁻¹ at A/F ratio: n.a.
1.8.8.	L1e — L7e	Maximum continuous total torque for propulsion(s): Nm at min ⁻¹ at A/F ratio: n.a.
1.8.9.	L1e — L7e	Maximum peak power for propulsion(s): kW at min ⁻¹ at A/F ratio: n.a.

Information Document M-HHA002

relating to EU type-approval of a noise-abatement device as a STU

TÜV SÜD Auto Service Technical Report: 25-00067-CM-GBM-00

4.		GENERAL INFORMATION ON ENVIRONMENTAL AND PROPULSION UNIT PERFORMANCE
4.0		General information on environmental and propulsion performance
4.0.1.	L1e — L7e	Environmental step: Euro (5/5+)
4.0.2.	L1e — L7e	Fuel consumption: see WVTA
4.0.3.	L1e — L7e	CO ₂ emissions: see WVTA
4.0.4.	L1e — L7e	Energy consumption: n.a.
4.0.5.	L1e — L7e	Electric range: n.a.
4.0.6.		Sound level
4.0.6.1.	L1e — L7e	Limit value for L_{urban} : see Technical Report
4.4.	L1e — L7e	Additional information on environmental and propulsion unit performance
4.4.4.	L1e — L7e	All additional technical informations according to UN Regulation No. 92, are mentioned in the Technical Report or shown in the attachments.

Anlage / <i>Enclosure</i>	Dokument-Nr. / <i>Document no.</i>	Datum / <i>Date</i>	Seiten / <i>Pages</i>
Zeichnung Gesamtanlage / <i>Drawing exhaust system</i>	-	-	1
Zeichnung(en) der Bauteil(e) der zu genehmigenden techn. Einheit / <i>Drawing(s) of the part(s) of the separate techn. unit</i>	133249-HOM	26.08.2025	1
Stückliste / <i>Part list</i>	M-HHA002	-	1
Einbauanleitung / <i>Mounting instructions</i>	KTM 1390 KTM 1290	-	12
ASEP-Erklärung / <i>ASEP Statement</i>	-	26.08.2025	1



Davorin Dobočnik, CEO

08.09.2025

Partial exhaust system / Slip-ON line / EC / ECE Type approval

- KTM 1390 Super Adventure S EVO**
- KTM 1390 Super Adventure R**
- KTM 1290 Super Adventure**
- KTM 1290 Super Adventure S**
- KTM 1290 Super Adventure R**

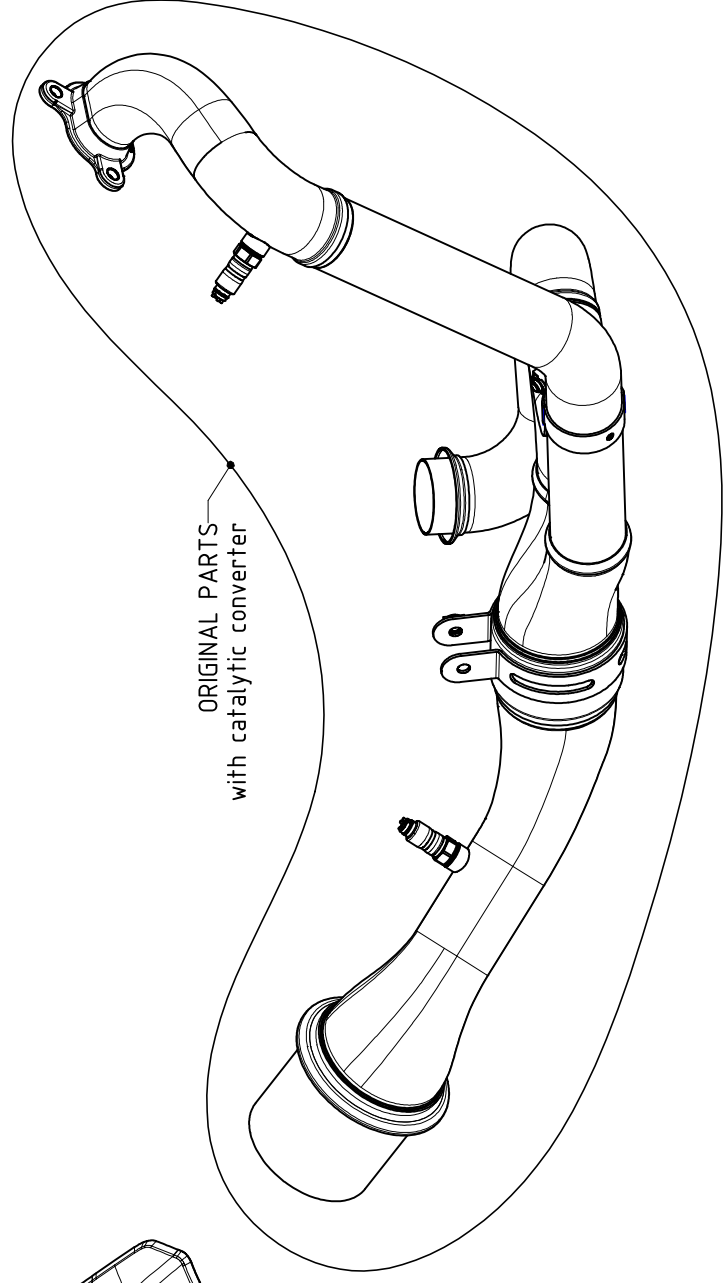
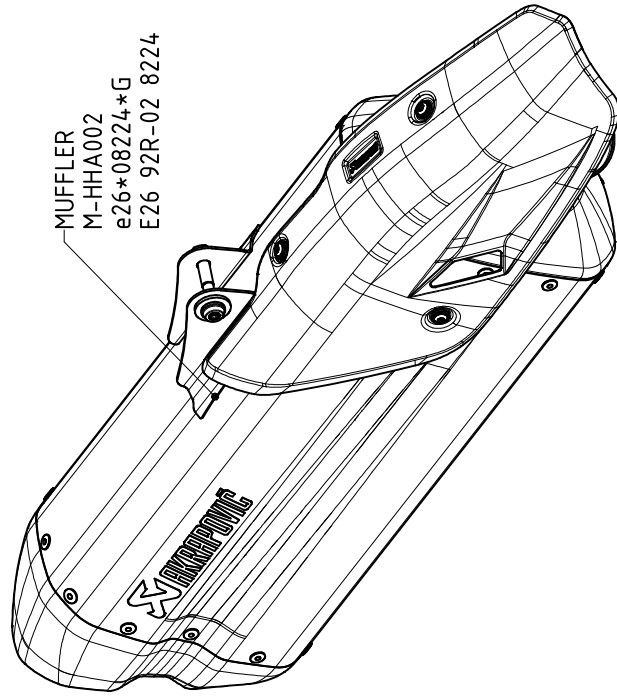
Product code: S-KTM12SO5-HHAT



Statement of compliance with the Additional Sound Emission Provisions

This statement is required for non-original replacement exhaust silencing systems (NORESS) without multiple, manually or electronically adjustable, rider selectable operating modes or without variable geometries specified for the use on L3 Category vehicles that are type approved pursuant to the amendments to UN Regulation No.41 and are subject to the ASEP-requirements series of amendments to UN Regulation No.41.

Akrapovič d.d., Malo Hudo 8a, 1295 Ivančna Gorica, attests that the non-original replacement exhaust silencing systems of this type **M-HHA002, (E26 92R-02 8224)**, comply with the applicable ASEP requirements of UN Regulation No.41 during the type approval procedure and its production.

Akrapovič d.d., Malo Hudo 8a, 1295 Ivančna Gorica, makes this statement in good faith, after having performed an appropriate evaluation of the sound emission performance of the non-original replacement exhaust silencing system in accordance with the requirements of UN Regulation No.92 during the type approval procedure and its production.

Akrapovič d.d.
Davorin Dobočnik, CEO

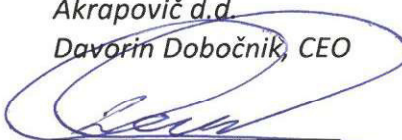

AKRAPOVIČ d.d.
Malo Hudo 8a, 1295 Ivančna Gorica

Date: 26.08.2025