



**CERTIFIKAT O ECE-HOMOLOGACIJI**  
**ECE COMPONENT TYPE-APPROVAL CERTIFICATE**

Sporočilo o podeljeni homologaciji za tip vozila glede na tip nadomestnega sistema za dušenje zvoka NORESS ali sestavnega dela v skladu s Pravilnikom št. 92 R, Amandma 02, Dodatek 00

*Communication concerning approval granted of a vehicle type with regard to a type of NORESS or component thereof pursuant to Regulation No. 92 R, Amendment 02, Supplement 00*

Homologacijska št.: **E26 92 R 02/00 8224**  
Approval No.:

Razširitev št.: **00**  
Extension No.:

- |   |  |
|---|--|
| 1. Blagovno ime ali znamka motocikla:<br><i>Trade name or mark of the motorcycle:</i>   | KTM  |
| 2. Tip motocikla:<br><i>Motorcycle type:</i>  | glej poročilo o preskusu<br><i>see the test report</i> |
| 3. Ime in naslov proizvajalca:<br><i>Manufacturer's name and address:</i>   | KTM (A)  |
| 4. Če pride v poštev, ime in naslov<br>predstavnika proizvajalca:<br><i>If applicable, name and address of<br/>manufacturer's representative:</i> | /  |
| 5. Motor<br><i>Engine</i>   |  |
| 5.1. Proizvajalec:<br><i>Manufacturer:</i>  | KTM (A)  |
| 5.2. Tip:<br><i>Type:</i>   | glej poročilo o preskusu<br><i>see the test report</i> |
| 5.3. Model:<br><i>Model:</i>  | /  |
| 5.4. Največja nazivna moč:<br><i>Rated maximum net power:</i>   | glej poročilo o preskusu<br><i>see the test report</i> |
| 5.5. Vrsta motorja:<br><i>Kind of engine:</i>   | na prisilni vžig<br><i>positive-ignition</i>           |
| 5.6. Način delovanja:<br><i>Cycles:</i>   | štiritaktni<br><i>four-stroke</i>                      |

---

5.7.	Prostornina valja: <i>Cylinder capacity:</i>	glej poročilo o preskusu <i>see the test report</i>
6.	Menjalnik <i>Transmission</i>	
6.1.	Vrsta menjalnika: <i>Type of transmission:</i>	ročni menjalnik <i>manual transmission</i>
6.2.	Število prestav: <i>Number of gears:</i>	6 prestav <i>6 gears</i>
7.	Oprema <i>Equipment</i>	
7.1.	Dušilnik zvoka <i>Exhaust silencer</i>	
7.1.1.	Proizvajalec ali pooblaščen zastopnik (če obstaja):  <i>Manufacturer or authorized representative (if any):</i>	AKRAPOVIC D.D. MALO HUDO 8A 1295 IVANCNA GORICA Slovenia
7.1.2.	Model: <i>Model:</i>	/
7.1.3.	Tip: <i>Type:</i>	M-HHA002
	v skladu s številko risbe: <i>in accordance with drawing No.:</i>	Muffler type M-HHA002
7.2.	Dušilnik zvoka na sesalni strani <i>Intake silencer</i>	originalen <i>original</i>
7.2.1.	Proizvajalec ali pooblaščen zastopnik (če obstaja):  <i>Manufacturer or authorized representative (if any):</i>	AKRAPOVIC D.D. MALO HUDO 8A 1295 IVANCNA GORICA Slovenia
7.2.2.	Model: <i>Model:</i>	/
7.2.3.	Tip: <i>Type:</i>	/
	v skladu s številko risbe: <i>in accordance with drawing No.:</i>	/
8.	Uporabljene prestave za izvajanje meritev v vožnji: <i>Gears used for test of motor cycle in motion:</i>	4 <i>4<sup>th</sup> gear</i>
9.	Končno prestavno razmerje(a): <i>Final drive ratio(s):</i>	1,900 / 2,471

---

10. ECE homologacijska številka pnevmatik(e):  
*ECE type approval number of tyre(s):* ni navedeno  
*no specification*
- Če ni na voljo, navesti naslednje podatke:  
*If not available, the following information shall be provided:*
- 10.1. Proizvajalec pnevmatik:  
*Tyre manufacturer:* glej poročilo o preskusu  
*see the test report*
- 10.2. Trgovska oznaka(e) tipa pnevmatik (po oseh), (npr: tovarniška oznaka, hitrostni razred in razred nosilnosti):  
*Commercial description(s) of the type of tyre (by axle), (e.g. trade name, speed index, load index):* glej poročilo o preskusu  
*see the test report*
- 10.3. Velikost pnevmatik (po oseh):  
*Tyre size (by axle):* glej poročilo o preskusu  
*see the test report*
- 10.4. Druge homologacijske številke (če so na voljo):  
*Other type approval number (if available):* /
11. Mase  
*Masses*
- 11.1. Največja tehnično dovoljena masa:  
*Maximum permissible gross weight:* glej poročilo o preskusu  
*see the test report*
- 11.2. Testna masa:  
*Test mass:* glej poročilo o preskusu  
*see the test report*
- 11.3. Indeks razmerja moči in mase (PMR):  
*Power to mass ratio index (PMR):* glej poročilo o preskusu  
*see the test report*
12. Dolžina vozila:  
*Vehicle length:* glej poročilo o preskusu  
*see the test report*
- 12.1. Referenčna dolžina  $l_{ref}$ :  
*Reference length  $l_{ref}$ :* glej poročilo o preskusu  
*see the test report*
13. Hitrost vozila pri meritvah v prstavi (i)  
*Vehicle speeds of measurements in gear (i)*
- 13.1. Hitrost vozila na začetku pospeševalnega cikla (povprečje 3 pospeševanj) za prestavo (i):  
*Vehicle speed at the beginning of the period of acceleration (average of 3 runs) for gear (i):* glej poročilo o preskusu  
*see the test report*
- 13.2. Dolžina pred začetkom pospeševanja za prestavo (i):  
*Pre-acceleration length for gear (i):* 0

13.3. Hitrost vozila $v_{PP}$ (povprečje 3 pospeševanj) za prestavo (i): <i>Vehicle speed <math>v_{PP}</math> (average of 3 runs) for gear (i):</i>	glej poročilo o preskusu <i>see the test report</i>
13.4. Hitrost vozila $v_{BB}$ (povprečje 3 pospeševanj) za prestavo (i): <i>Vehicle speed <math>v_{BB}</math> (average of 3 runs) for gear (i):</i>	glej poročilo o preskusu <i>see the test report</i>
14. Hitrosti vozila pri meritvah v prestavi (i+1) (če pride v poštev) <i>Vehicle speeds of measurements in gear (i+1) (if applicable)</i>	
14.1. Hitrost vozila na začetku pospeševalnega cikla (povprečje 3 pospeševanj) za prestavo (i+1): <i>Vehicle speed at the beginning of the period of acceleration (average of 3 runs) for gear (i+1):</i>	ne pride v poštev <i>not applicable</i>
14.2. Dolžina pred začetkom pospeševanja za prestavo (i+1): <i>Pre-acceleration length for gear (i+1):</i>	ne pride v poštev <i>not applicable</i>
14.3. Hitrost vozila $v_{PP}$ (povprečje 3 pospeševanj) za prestavo (i+1): <i>Vehicle speed <math>v_{PP}</math> (average of 3 runs) for gear (i+1):</i>	ne pride v poštev <i>not applicable</i>
14.4. Hitrost vozila $v_{BB}$ (povprečje 3 pospeševanj) za prestavo (i+1): <i>Vehicle speed <math>v_{BB}</math> (average of 3 runs) for gear (i+1):</i>	ne pride v poštev <i>not applicable</i>
15. Pospeški so izračunani med linijami AA' in BB'/PP' in BB' <i>Accelerations are calculated between lines AA' and BB'/PP' and BB'</i>	
15.1. Opis delovanja naprav za stabilizacijo pospeševanja (če pride v poštev): <i>Description of functionality of devices used to stabilize the acceleration (if applicable):</i>	ne pride v poštev <i>not applicable</i>
16. Ravni hrupa v vožnji <i>Noise levels of moving vehicle</i>	
16.1. Rezultati merjenja pri polnem plinu $L_{wot}$ : <i>Wide-open-throttle test result <math>L_{wot}</math>:</i>	glej poročilo o preskusu <i>see the test report</i>
16.2. Rezultati merjenja v vožnji $L_{crs}$ : <i>Constant speed test results <math>L_{crs}</math>:</i>	glej poročilo o preskusu <i>see the test report</i>
16.3. Delni faktor moči $k_p$ : <i>Partial power factor <math>k_p</math>:</i>	0,492 / 0,510
16.4. Končni rezultat merjenja $L_{urban}$ : <i>Final test result <math>L_{urban}</math>:</i>	glej poročilo o preskusu <i>see the test report</i>

17. Raven hrupa v mirovanju  
*Noise level of stationary vehicle*
- 17.1. Pozicija in smer mikrofona  
(skladno z dodatkom 2, Priloga 3,  
pravilnika ECE 41 R, amandma 04):  
*Position and orientation of microphone  
(according to Appendix 2 of Annex 3 of 04  
series of regulation No. 41):*
- 17.2. Rezultat merjenja v mirovanju:  
*Test result for stationary test:*
18. Dodatne določbe za emisije hrupa:  
*Additional sound emission provisions:*
19. Referenčna skladnost podatkov v uporabi  
*In-use compliance reference data*
- 19.1. Za meritev izbrana prestava (i) ali,  
izbrana lega izbirnika prestave,  
pri vozilih z varibalnim menjalnikom:  
*Gear (i) or, for vehicles tested with non-locked  
gear ratios, the position of the gear selector chosen  
for the test:*
- 19.2. Dolžina pred začetkom pospeševanja  $l_{PA}$ :  
*Pre-acceleration length  $l_{PA}$ :*
- 19.3. Hitrost vozila na začetku pospeševalnega cikla  
(povprečje 3 pospeševanj) za prestavo (i):  
*Vehicle speed at the beginning of the period  
of acceleration (average of 3 runs) for gear (i):*
- 19.4. Raven zvočnega tlaka  $L_{wot(i)}$ :  
*Sound pressure level  $L_{wot(i)}$ :*
20. Datum predložitve vozila v postopek homologacije:  
*Date of submission of vehicle for approval:*
- glej točko 3.5.3. poročila o preskusu  
25-00068-CM-GBM-00
- see point 3.5.3. of the test report  
25-00068-CM-GBM-00
- glej poročilo o preskusu  
see the test report
- glej točko 3.5.3. poročila o preskusu  
25-00068-CM-GBM-00 in  
priložene risbe  
see point 3.5.3. of the test report  
25-00068-CM-GBM-00 and  
attached drawings
- 4
- 4<sup>th</sup> gear
- 0 m
- glej poročilo o preskusu  
see the test report
- glej poročilo o preskusu  
see the test report
- glej poročilo o preskusu  
see the test report

21. Tehnična služba odgovorna za homologacijske preskuse:  
*Technical service responsible for conducting approval tests:* TÜV SÜD Auto Service GmbH  
Westendstraße 199  
D-80686 München  
Germany
22. Datum poročila o preskusu, ki ga je izdala ta služba:  
*Date of test report issued by that Service:* 08.09.2025
23. Številka poročila o preskusu, ki ga je izdala ta služba:  
*Number of test report issued by that Service:* 25-00068-CM-GBM-00
24. Homologacija:  
*Approval:* **podeljena**  
**granted**
25. Mesto homologacijske oznake na vozilu:  
*Position of approval mark on the vehicle:* vgravirano z laserjem / tablica  
pritrjena s kovicami  
*engraved by laser / plate fixed with rivets*
26. Kraj:  
*Place:* 1000 LJUBLJANA
27. Datum:  
*Date:* 06.10.2025
28. Podpis:  
*Signature:* mag. Tomaž Svetina, univ.dipl.inž.  
vodja sektorja za vozila **TOMAŽ**  
**SVETINA**
29. Temu sporočilu je priložen seznam dokumentov, ki so deponirani pri homologacijskem organu, ki je odobril to homologacijo in jih je na zahtevo mogoče dobiti:  
**glej kazalo opisne dokumentacije št. E8224 Rev.00**  
*The list of documents deposited with the Administrative Service which has granted approval is annexed to this communication and may be obtained on request:*  
**see index to information package No E8224 Rev.00**

Ta homologacija se uporablja za tip serijsko izdelanih neoriginalnih nadomestnih sistemov za dušenje zvoka (RESS) ali njegovih sestavnih delov pod naslednjimi pogoji:

Posamezni proizvodi iz serijske proizvodnje morajo ustrezati najmanj vsem zahtevam Pravilnika št. 92R, Amandma 02, Dodatek 00, "Enotni pogoji za homologiranje neoriginalnih nadomestnih sistemov za dušenje zvoka (RESS) za motorna kolesa, mopede in trikolesna vozila".

Priloženo poročilo o preskusu in risbe so sestavni del te homologacije.

Vsak sestavni del neoriginalnega nadomestnega sistema za dušenje zvoka, vendar ne deli in cevi za vgradnjo, mora biti čitljivo in trajno označen z:

- znamko (tovarniškim imenom ali oznako proizvajalca),
- trgovskim imenom,
- homologacijsko oznako.

Temu tipu proizvoda se dodeli naslednja homologacijska oznaka:

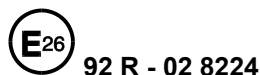

Homologacijska oznaka na proizvodu mora po izvedbi in velikosti ustrezati zahtevam Pravilnika št. 92 R.02.

S tem homologacijskim znakom so lahko označeni samo tisti proizvodi, ki v celoti ustrezajo homologacijski dokumentaciji.

Homologacijska oznaka na proizvodu mora biti nameščena na mestu, ki je označeno v homologacijski dokumentaciji. Mesto homologacijske oznake mora biti izbrano tako, da je oznaka jasno čitljiva tudi po vgradnji v vozilo.

Proizvod je lahko označen tudi s tujo homologacijsko ali drugo oznako, če s tem ni motena razpoznavnost in čitljivost homologacijske oznake, ki jo je dodelil slovenski homologacijski organ.

Na proizvodu ne sme biti oznak, ki bi lahko privedle do zamenjave z uradno dodeljeno oznako.

Kakršnekoli spremembe na proizvodu so dovoljene samo na podlagi posebnega dovoljenja homologacijskega organa.

Veljavnost homologacije preneha z vrnitvijo ali z odvzemom. Homologacija se odvzame, če pogoji za podelitev in obstoj homologacije ne obstajajo več, če lastnik homologacije krši obveznosti, povezane s homologacijo, oziroma če se ugotovi, da homologirani proizvod ne ustreza več veljavnim predpisom.

Proizvajalec je dolžan stalno kontrolirati kakovost homologiranega proizvoda in njegovo skladnost s homologacijsko dokumentacijo. O tej kontroli je dolžan voditi evidenco in omogočiti vpogled v zapiske nadzornemu organu, ki ga določi homologacijski organ. V primeru ugotovitve neskladnosti s homologacijsko dokumentacijo je proizvajalec dolžan o tem takoj obvestiti homologacijski organ.

Homologacijski organ lahko kadarkoli preverja pravilno izvajanje pooblastil, dodeljenih s to homologacijo, in v ta namen tudi izbira vzorce za ponovni preskus. Stroške takšnih pregledov in presoj skladnosti proizvodnje, se zaračunajo proizvajalcu.

Vsako spremembo oznake proizvajalca, naslova ali proizvodne tovarne oziroma pri homologaciji imenovane pooblaščen osebe je treba takoj sporočiti homologacijskemu organu.

Pravice, podeljene s to homologacijo, so neprenosljive. Pravice tretjih s to homologacijo niso prizadete.

V primerih, da se proizvodnja ali prodaja proizvoda ne začne v roku enega leta od podelitve homologacije, da se proizvodnja ali prodaja prekine za več kot eno leto oziroma, da se predvideva taka prekinitve, je o tem treba takoj obvestiti homologacijski organ.

O začetku proizvodnje ali začetku prodaje oziroma njihovem ponovnem začetku je treba obvestiti homologacijski organ najkasneje v enem mesecu.

Neupoštevanje zgoraj navedenih določil lahko povzroči odvzem homologacije in se kazensko preganja.

Pravno razlago v zvezi s to homologacijo lahko daje samo homologacijski organ.

06.10.2025

mag. Tomaž Svetina, univ.dipl.inž.  
vodja sektorja za vozila

*This Approval shall apply to a type of non-original replacement exhaust silencing systems (RESS) or its components from serial production under the following conditions:*

*Individual products from serial production shall comply at least with all requirements set out in the Regulation No. 92 R, Amendment 02, Supplement 00 "Uniform provisions concerning the approval of non-original replacement exhaust silencing systems (RESS) for motorcycles, mopeds and three-wheeled vehicles".*

*The attached test report and drawings shall be a constituent part of this Approval.*

*Each component of the nonoriginal replacement exhaust silencing system, excluding pipes and fitting accessories, shall be marked with a readable and durable:*

- *make (trade name or mark of manufacturer),*
- *commercial name,*
- *approval marking.*

*This type of product shall be allotted the following approval marking:*

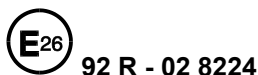

*The design and size of the approval marking shall meet the requirements of the Regulation No. 92 R.*

*Only products which fully comply with the approval documentation may bear the allotted approval mark.*

*The approval marking on the product must be attached at the place indicated in the approval documentation. Location of the approval marking shall be selected in such way that the marking is clearly readable even when installed on a vehicle.*

*The product may also be marked with a foreign approval or other marking, provided that the identifiability and readability of the approval marking granted by the Slovenian Type Approval Authority is not affected.*

*The product shall not bear any markings that may lead to confusion with the officially allotted marking.*

*Changes of any kind performed on the product shall be subject to special permission by the Slovenian Type Approval Authority.*

*The Approval will become ineffective when returned or withdrawn. The Approval shall be withdrawn: should the conditions for its granting and existence no longer exist, should the owner of the Approval break his obligations related to the Approval, or when it has been established that the approved product no longer complies with the applicable regulations.*

*The manufacturer shall regularly inspect the quality of the approved product as well as its conformity with the approval documentation. He shall keep record of this inspection and allow to the surveillance body appointed by the Slovenian Type Approval Authority access to the records. Should any non-conformities be found with respect to the approval documentation, the manufacturer shall immediately inform thereof the Slovenian Type Approval Authority.*

*Any time, the Slovenian Type Approval Authority may check the correct implementation of the authorizations appointed through this Approval, and for this purpose also select samples for a repeated test. The costs of such checks and conformity of production assessments are charged to the manufacturer.*

*Any changes regarding the manufacturer's marking, the address or the production plant, or the authorized person appointed through this Approval, shall be forthwith notified to the Slovenian Type Approval Authority.*

---

*The rights granted through this Approval shall be untransferrable. The rights of third persons shall not be affected through this Approval.*

*In the case where the production or sale of the product does not start within one year after the granting of the Approval, or the production or sale is interrupted for a period longer than one year, or such interruption is foreseen, the Slovenian Type Approval Authority shall be immediately notified.*

*The Slovenian Type Approval Authority shall be notified of the start of production or start of sale, or its restart, within a month's time at the latest.*

*Non-compliance with above stated provisions may result in withdrawal of the Approval and will be prosecuted.*

*Legal explanations in relation with this Approval may only be given by the Slovenian Type Approval Authority.*

06.10.2025

Tomaž Svetina, M.Sc.Eng.  
Head of Vehicle department

**SLOVENIAN TRAFFIC SAFETY AGENCY,  
KOTNIKOVA ULICA 19a,  
1000 LJUBLJANA,  
SLOVENIA**

We, Akrapovič d.d., Malo Hudo 8a. 1295 Ivančna Gorica, Slovenia hereby ask STSA to grant approval against **ECE-R92 02** for the following product:  
Exhaust system for Motorcycles:

Type: **M-HHA002**

Version: **M-HHA002 05T (Ti / Ti / Ca)**  
**M-HHA002 02T (SS / Ti / Ca)**  
**M-HHA002 06T (Ti / Ti / Ti)**  
**M-HHA002 03T (SS / Ti / Ti)**  
**M-HHA002 05TBL (Ti / Ti / Ca)**  
**M-HHA002 02TBL (SS / Ti / Ca)**  
**M-HHA002 06TBL (Ti / Ti / Ti)**  
**M-HHA002 03TBL (SS / Ti / Ti)**

Manufacturer: **Akrapovič d.d.**  
**Malo Hudo 8a**  
**1295 Ivančna Gorica**  
**Slovenia**

We declare that we have not applied to any other Approval Authority in the EU Member States for this approval.

We have requested **TÜV SÜD Auto Service GmbH**, to carry out all testing required by the directive and/or regulation that the approval is sought against and to present the entire documentation for the approval.

Yours sincerely,



Akrapovič d.d.  
Davorin Dobočnik, CEO

Date: 20.11.2024



**JAVNA AGENCIJA  
REPUBLIKE SLOVENIJE  
ZA VARNOST PROMETA**

-----  
**Sektor za vozila**

Kotnikova 19a  
1000 Ljubljana  
Slovenija  
telefon: 01 400 84 30  
telefaks: 01 400 84 17  
<http://www.avp-rs.si>

Številka: 37141-070/2024/02

Datum: 01.12.2024

AKRAPOVIČ D.D.  
REGULATORY DEPARTMENT  
g./ga. MARKO ŠTAMCAR  
MALO HUDO 8A

**Zadeva: Rezervacija homologacijske številke**

Spoštovani!

Sporočamo Vam rezervirano homologacijsko številko za:

Znamka: AKRAPOVIČ  
Tip: M-HHA002  
Opis: NADOMESTNI GLUŠNIKI ZA MOTOCIKLE (RESS)  
Direktiva / pravilnik: 92 R 02 - Nadomestni glušniki za motocikle, mopede in trikolesna vozila

REZERVACIJA: 92 R 02 8224\*00

PRI ORIGINALNI VLOGI OBVEZNO NAVESTI, DA GRE ZA DOPOLNITEV VLOGE: 37141-070/2024/02

Lep pozdrav!

Poslano:  
- AKRAPOVIČ D.D.



Digitally signed  
by JOŽE TRŠELIČ  
Date: 2025.10.06  
08:36:52 +02'00'

## PRÜFBERICHT TEST REPORT

**Nr. / no. 25-00068-CM-GBM-00**

über die Prüfung einer Nicht-Originalauspuffanlage oder  
von Einzelteilen hiervon als Technische Einheit für Krafträder gemäß  
ECE-R 92, Änderungsserie 02  
Einheitliche Bedingungen für die Genehmigung von nicht-originalen Austausch-  
Schalldämpferanlagen für Krafträder, Mopeds und Dreiradfahrzeuge. /

*about a test of a non-original exhaust system or a component  
as a separate technical unit for motorcycles according to  
ECE-R 92, 02 series of amendments*

*Uniform provisions concerning the approval of non-original replacement exhaust silencing  
systems (NORESS) for motorcycles, mopeds, and three-wheeled vehicles*

Genehmigungsstand / Approval status	
<input checked="" type="checkbox"/>	Erteilung einer Typgenehmigung <i>Granting of a type approval</i> <b>E26 92R-02 8224*00</b>
<input type="checkbox"/>	Nachtrag/Änderung zur Typgenehmigung Nr. <i>Extension/correction to type approval no.</i>

### Gründe der Erweiterung / Reasons for extension

Es wird geändert /  
*It will be changed:* -

Es kommt hinzu /  
*It will be added:* -

Es wird aktualisiert /  
*It will be updated:* -



**0. Allgemeine Angaben / General information**

0.1. Fabrikmarke / Make: AKRAPOVIČ

0.2. Typ / Type: M-HHA002

0.2.1. Ausführungen / Variants:

Ausführungen / Variants	Material / Material		
	Rohre / Tubes	Außenmantel / Sleeve	Endkappe / End cap
M-HHA002 05T	Titan / Titan	Titan / Titan	Karbon / Carbon
M-HHA002 02T	VA / Stainless steel	Titan / Titan	Karbon / Carbon
M-HHA002 06T	Titan / Titan	Titan / Titan	Titan / Titan
M-HHA002 03T	VA / Stainless steel	Titan / Titan	Titan / Titan
M-HHA002 05TBL	Titan / Titan	Titan / Titan	Karbon / Carbon
M-HHA002 02TBL	VA / Stainless steel	Titan / Titan	Karbon / Carbon
M-HHA002 06TBL	Titan / Titan	Titan / Titan	Titan / Titan
M-HHA002 03TBL	VA / Stainless steel	Titan / Titan	Titan / Titan

Die Ausführungen unterscheiden sich in der Verwendung verschiedener Werkstoffe. Der konstruktive Aufbau ist gleich. Das akustische Verhalten ist als gleichwertig zu betrachten. /

*The variants vary because different materials are used. The basic construction remains the same. The acoustic behaviour is to be regarded as equivalent.*

0.3. Name und Anschrift des Herstellers /  
 Name and address of manufacturer: Akrapovič d.d.  
 Malo Hudo 8a  
 SLO-1295 Ivančna Gorica

0.4. Name und Anschrift des Beauftragten /  
 Name and address of authorized agent: entfällt / n.a.

0.5. Nr. des Beschreibungsbogens /  
 No. of information document: M-HHA002  
 Ausgabedatum / Date: 08.09.2025

## **1. Verwendungsbereich / Application range**

- 1.1. Klasse der Fahrzeuge für die die Anlage bestimmt ist /  
*Class of the vehicles the unit is used for:* L3e
- 1.2. Beschreibung der Fahrzeuge für die die Einrichtung bestimmt ist /  
*Description of the vehicles the unit is used for:* siehe Anlage 2 / see enclosure 2

## **2. Angaben zum Prüfobjekt / Composition of the separate technical unit**

- 2.1. Art der Technischen Einheit / *Kind of technical unit:*  
Technische Einheit, bestehend aus einem Schalldämpfer nach Zeichnung Nr. 133249-HOM, oval 126,8 x 201,8 x 420 mm, Absorptionsprinzip mit Eintritts- und Austrittsrohren gem. Anlage 1. / *Technical unit, consisting of a silencer according to drawing no. 133249-HOM, oval 126,8 x 201,8 x 420 mm, absorption-principle with inlet and outlet pipes according to enclosure 1.*
- 2.2. Ort der Kennzeichnung /  
*Place of marking:* Lasergravur, Typschild aufgenietet /  
*Engraved by laser, plate fixed with rivets*
- 2.3. Zusammenstellung der techn. Einheit /  
*Composition of the separate technical unit:* siehe Anlage 1 / see enclosure 1
- 2.4. Lage und Richtung der Auspuffmündung /  
*Position and direction of the tail pipe:* rechts seitlich nach hinten /  
*right side to the rear*

### 3. Prüfprotokoll / Test report

Die Prüfungen wurden in 2 Versuchsreihen A und B mit folgenden Fahrzeugen durchgeführt. /

*The tests were carried out in 2 series A and B with following vehicles:*

Versuchsreihe A / Series A: (Ifd. Nr. / no. 3, Messdatum / Date 01.09.2025)

#### 3.1. Fahrzeug / Vehicle

3.1.1. Typ / Type:	KTM V2 Adventure
3.1.1.1 Variante / Version / Variant / Version:	C1 / -
3.1.1.2 Fahrzeugkategorie / Category:	L3e-A3
3.1.1.3 Handelsbezeichnung / Model:	KTM 1290 Super Adventure R
3.1.2. Hersteller / Manufacturer:	KTM AG Stallhofnerstr. 3 A-5230 Mattighofen
3.1.3. Genehmigungs-Nr. / Homologation no.:	e1*168/2013*00274*
3.1.3.1 Nachtrag bzw. Erweiterung / Extension:	00
3.1.4. Fahrzeugidentifizierungsnummer / Vehicle identification no.:	VBKV59403PM977026
3.1.5. Baujahr / Year of manufacture:	2024
3.1.6. Km-Stand / Kilometers:	9743
3.1.7. Zul. Gesamtgewicht / Total weight:	450 kg

#### 3.2. Antriebsmaschine / Engine

3.2.1. Hersteller / Manufacturer:	KTM
3.2.2. Typ / Type:	619
3.2.3. Hubraum / Engine capacity:	1301 cm <sup>3</sup>
3.2.4. Höchstleistung / Max. net power:	118 kW bei / at 9000 min <sup>-1</sup>
3.2.5. Max. Drehmoment / Max. net torque:	138 Nm bei / at 6500 min <sup>-1</sup>

### 3. **Prüfprotokoll** (Fortsetzung) / **Test report** (continuation)

#### 3.3. **Kraftübertragung / Transmission**

- 3.3.1. Art der Kraftübertragung /  
*Kind of transmission:* mechanisch / *mechanical*
- 3.3.2. Getriebe / *Gearbox:* 6-Gang-manuell / *6-gear-manual*
- 3.3.3. Übersetzungsverhältnisse /  
*Transmission ratios*  
primär / *primary* / sekundär / *secondary:* 1,900 / 2,471
- Höchstgeschwindigkeit / *Top speed:* 235 km/h
- Reifen / *Tires:* Bridgestone Battlax Adventure  
Achse / *Axle 1:* 90/90-21 M/C 54V  
Achse / *Axle 2:* 150/70 R18 M/C 70V

#### 3.4. **Zusammenbau der Auspuffanlage / Assembly of the exhaust system** (Teile lfd. Nr. lt. Anlage 1 / *no. of parts acc. enclosure 1*)

Versuchsreihe A / *Series A:* 1)2a)

#### 3.5. **Messung der Geräuschwerte / Acoustic measurements**

- 3.5.1. Hersteller des Messgerätes /  
*Manufacturer of test equipment:* MÜLLER-BBM
- 3.5.2. Typ des Messgerätes /  
*Type of the test equipment:* PAK MK II Configuration
- 3.5.3. Fahrgeräusch, Standgeräusch /  
*Drive by noise, stationary noise:* nach ECE-R 41.05 /  
*according ECE-R 41.05*
- 3.5.3.1 Position des Mikrofons /  
*Position of the microphone:* gemäß UN-R41 Anhang 3 Anlage 2,  
rechte Fahrzeugseite /  
*acc. to UN-R41 Annex 3 Appendix 2,*  
*right side of the vehicle*
- 3.5.4. Beladungszustand bei der Fahr-  
geräuschmessung /  
*Load condition during drive by test:* Leergewicht zuzüglich 75 kg Fahrer /  
*Unloaded weight plus 75 kg driver*
- 3.5.5. Abweichung bei Kalibrierung /  
*Deviation at calibration:* < 0.2 dB(A)

### 3. **Prüfprotokoll** (Fortsetzung) / **Test report** (continuation)

#### 3.6. **Messung der Leistung / Power measurement**

##### 3.6.1. Messung der Leistungskurve mit Nicht-Originalauspuffanlage / *Testing of max. power with non-original exhaust system:*

Die gemessene Nennleistung und die zugehörige Drehzahl liegen im Toleranzbereich von 5% im Vergleich zu den mit der Originalauspuffanlage gemessenen Werten (siehe Anlage). /

*The tested max. power und the engine speed is in the 5% tolerance in comparison with the original exhaust system (see enclosure).*

##### 3.6.2. Messung der Höchstgeschwindigkeit mit Nicht-Originalauspuffanlage / *Testing of top speed with non-original exhaust system:*

entfällt, da Fahrzeugklasse /  
*not applicable, because vehicle class:* L3e

Versuchsreihe B / Series B: (Ifd. Nr. / no. 5, Messdatum / Date 19.11.2024)

#### 3.1. **Fahrzeug / Vehicle**

3.1.2. Typ / Type:	KTM V2 ADV
3.1.1.1 Variante / Version / Variant / Version:	B / -
3.1.1.2 Fahrzeugklasse / Category:	L3e-A3
3.1.1.3 Handelsbezeichnung / Model:	KTM 1390 Super Adventure S EVO
3.1.2. Hersteller / Manufacturer:	KTM AG Stallhofnerstr. 3 A-5230 Mattighofen
3.1.3. Genehmigungs-Nr. / Homologation no.:	e1*168/2013*00403*
3.1.3.1 Nachtrag bzw. Erweiterung / Extension:	00
3.1.4. Fahrzeugidentifizierungsnummer / Vehicle identification no.:	VBKV79P37SM901589
3.1.5. Baujahr / Year of manufacture:	2024
3.1.6. Km-Stand / Kilometers:	130
3.1.7. Zul. Gesamtgewicht / Total weight:	475 kg

### **3. Prüfprotokoll (Fortsetzung) / Test report (continuation)**

#### **3.2. Antriebsmaschine / Engine**

- 3.2.1. Hersteller / *Manufacturer:* KTM
- 3.2.2. Typ / *Type:* A626
- 3.2.3. Hubraum / *Engine capacity:* 1350 cm<sup>3</sup>
- 3.2.4. Höchstleistung / *Max. net power:* 127 kW bei / *at* 9500 min<sup>-1</sup>
- 3.2.5. Max. Drehmoment / *Max. net torque:* 145 Nm bei / *at* 8000 min<sup>-1</sup>

#### **3.3. Kraftübertragung / Transmission**

- 3.3.1. Art der Kraftübertragung /  
*Kind of transmission:* mechanisch / *mechanical*
- 3.3.2. Getriebe / *Gearbox:* 6-Gang-manuell / *6-gear-manual*
- 3.3.3. Übersetzungsverhältnisse /  
*Transmission ratios*  
primär / *primary* / sekundär / *secondary:* 1,900 / 2,471
- Höchstgeschwindigkeit / *Top speed:* 250 km/h
- Reifen / *Tires:* Dunlop Trailmax Meridian  
Achse / *Axle 1:* 120/70 ZR19 60W  
Achse / *Axle 2:* 170/60 ZR17 72W

#### **3.4. Zusammenbau der Auspuffanlage / Assembly of the exhaust system** (Teile lfd. Nr. lt. Anlage 1 / *no. of parts acc. enclosure 1*)

Versuchsreihe B / *Series B:* 1)2a)

#### **3.5. Messung der Geräuschwerte / Acoustic measurements**

- 3.5.1. Hersteller des Messgerätes /  
*Manufacturer of test equipment:* MÜLLER-BBM
- 3.5.2. Typ des Messgerätes /  
*Type of the test equipment:* PAK MK II Configuration

### 3. **Prüfprotokoll** (Fortsetzung) / **Test report** (continuation)

- 3.5.3. Fahrgeräusch, Standgeräusch /  
*Drive by noise, stationary noise:* nach ECE-R 41.05 /  
*according ECE-R 41.05*
- 3.5.3.1 Position des Mikrofons /  
*Position of the microphone:* gemäß UN-R41 Anhang 3 Anlage 2,  
*rechte Fahrzeugseite /*  
*acc. to UN-R41 Annex 3 Appendix 2,*  
*right side of the vehicle*
- 3.5.4. Beladungszustand bei der Fahr-  
geräuschmessung /  
*Load condition during drive by test:* Leergewicht zuzüglich 75 kg Fahrer /  
*Unloaded weight plus 75 kg driver*
- 3.5.5. Abweichung bei Kalibrierung /  
*Deviation at calibration:* < 0.2 dB(A)

### 3.6. **Messung der Leistung / Power measurement**

- 3.6.1. Messung der Leistungskurve mit Nicht-Originalauspuffanlage /  
*Testing of max. power with non-original exhaust system:*

Die gemessene Nennleistung und die zugehörige Drehzahl liegen im Toleranzbereich von 5% im Vergleich zu den mit der Originalauspuffanlage gemessenen Werten (siehe Anlage). /

*The tested max. power and the engine speed is in the 5% tolerance in comparison with the original exhaust system (see enclosure).*

- 3.6.2. Messung der Höchstgeschwindigkeit mit Nicht-Originalauspuffanlage /  
*Testing of top speed with non-original exhaust system:*

entfällt, da Fahrzeugklasse /  
*not applicable, because vehicle class:* L3e

### 3.7. **Konditionierung der Auspuffschalldämpferanlage /** **Conditioning of silencer system**

durch Druckschwingungen / *by pulsation*

### 3. **Prüfprotokoll** (Fortsetzung) / **Test report** (continuation)

#### 3.8. **Ergebnisse / Test results**

Die Ergebnisse der Prüfungen hinsichtlich / *The test results of*

- 3.8.1. Geräuschmessung / *Noise testing*
- 3.8.2. Leistungsmessung / *Power measurement*

sind der als Anlage beigefügten Tabellen zu entnehmen. /  
*are attached in the enclosures.*

Aufgrund der durchgeführten Messungen mit Original- und Nicht-Original-Auspuffanlage können die Punkte 6.2 bis 6.5 der ECE-R 92 als erfüllt betrachtet werden. /

*The results of the tests with the original and non-original exhaust system show that item 6.2 to 6.5 of the directive ECE-R 92 is fulfilled.*

- 3.8.3. Die beschriebene Nicht-Originalauspuffanlage / Technische Einheit darf an den in der Anlage 2 aufgeführten Kraftfahrzeugen unter den dort genannten Bedingungen verwendet werden. /  
*The described non-original exhaust system / technical unit is suitable for an application at the vehicles listed in enclosure 2.*
- 3.8.4. Die allgemeinen Spezifikationen gemäß Punkt 6.1 der ECE-R 92 wurden überprüft und werden durch die Nicht-Originalauspuffanlage / Technische Einheit erfüllt. /  
*The general specifications concerning item 6.1 of the directive ECE-R 92 were checked and are fulfilled.*

#### 4. **Anlagen / Enclosures**

Anlage 1: Teile der technischen Einheit (1 Seite / Page)  
*Enclosure 1: Composition of the separate technical unit*

Anlage 2: Verwendungsbereich (1 Seite / Page)  
*Enclosure 2: Field of application*

Anlage 3: Ergebnisse der Prüfungen (8 Seiten / Pages)  
*Enclosure 3: Test results*



## 5. Schlussbescheinigung / Summary

Das beschriebene Prüfobjekt entspricht der genannten Prüfspezifikation. Das Prüfobjekt wurde als ungünstigster Fall entsprechend der Prozessbeschreibung "Anforderungen an Prüfberichte (AS-PB-T-02)" aus der Beschreibung des Typs (Beschreibungsmappe) ausgewählt. Somit erfüllt auch der beschriebene Typ die o. a. Prüfspezifikation.

In Bezug auf die Einhaltung der Grenzwerte wurde die Messunsicherheit nicht berücksichtigt.

Der Hersteller trägt die Verantwortung für die zu Verfügung gestellten Informationen und Prüfmuster. Die Prüfergebnisse beziehen sich auf die erhaltenen und genannten Prüfmuster. Diese sind repräsentativ für den beschriebenen Typ.

Der Prüfbericht darf nur vom Auftraggeber und nur in vollem Wortlaut vervielfältigt und weitergegeben werden. Eine auszugsweise Vervielfältigung und Veröffentlichung des Prüfberichtes sind nur nach schriftlicher Genehmigung zulässig. /

*The test object described conforms to the mentioned test specification. The worst-case configuration was selected from the type of description (information folder) in accordance with the process description "Requirements for Test Reports (AS-PB-T-02)". Thus, the described type conforms to the test specification.*

*In question of meeting the limits the measurement uncertainty was ignored.*

*The manufacturer is responsible for the information and the test specimens provided by him. The test results relate only to the test specimens as received and mentioned. The test specimens are representative for the type described.*

*The test report may be reproduced and published in full and by the client only. It can be reproduced partially with the written permission of the test laboratory only.*



**5. Schlussbescheinigung (Fortsetzung) / Summary (continuation)**

TÜV SÜD Auto Service GmbH ist benannt als Technischer Dienst durch:  
*TÜV SÜD Auto Service GmbH is designated as Technical Service by:*

<b>Genehmigungsbehörde</b> <i>Approval authority</i>	<b>Land</b> <i>Country</i>	<b>Registriernummer</b> <i>Registration number</i>
Kraftfahrt-Bundesamt (KBA)	Deutschland <i>Germany</i>	KBA-P 00100-10
Vehicle Certification Agency (VCA)	Vereinigtes Königreich <i>United Kingdom</i>	VCA-TS-006
Approval Authority of the Netherlands (RDW)	Niederlande <i>The Netherlands</i>	RDWT-082-xx
National Standards Authority of Ireland (NSAI)	Irland <i>Ireland</i>	49
Swedish Transport Agency (STA)	Schweden <i>Sweden</i>	TT 0024
Société Nationale de Certification et d'Homologation s.a.	Luxemburg <i>Luxembourg</i>	13/B(g)
Vehicle Safety Certification Center (VSCC)	Taiwan <i>Taiwan</i>	DE04-06-2

Dieser Bericht umfasst Seite 1 bis 11. /  
*This test report contains the pages 1 up to 11.*

München, 08.09.2025

F. Rinske (B. Eng.)  
Sachverständiger / *Recognized Expert*  
fr  
M-HHA002\_ECE\_0.docx





Prüfbericht Nr. / Test report No.: 25-00068-CM-GBM-00  
Hersteller / Manufacturer: Akrapovič, d.d., SLO-1295 Ivancna Gorica  
Typ / Type: M-HHA002

## ANLAGE 1 ENCLOSURE 1

### Teile der technischen Einheit / Composition of the separate technical unit

Lfd. Nr. / No.	Einzelteile, Abmessungen in mm / Components parts, dimensions in mm	Abmessungen des Teiles in mm bzw. Originalteil / Ersatzteil / Dimensions of the part in mm or original part / replacement part	Teilenummer bzw. Genehmigungsnummer / Part no. or homologation no.
1)	Krümmerröhre mit Katalysator / Header pipes with catalytic converter	Originalteile / Original parts	-
2a)	Schalldämpfer / Silencer (Eintrittsrohr / Inlet pipe Ø 88 2 Austrittsrohre / Outlet pipes Ø 28 / 32)	oval 126,8 x 201,8 Länge ohne Endkappe / Length without end cap 420	M-HHA002 e26*08224*G E26 92R-02 8224

M-HHA002\_ECE\_1.docx



Prüfbericht Nr. / Test report No.: 25-00068-CM-GBM-00  
 Hersteller / Manufacturer: Akrapovič, d.d., SLO-1295 Ivanačna Gorica  
 Typ / Type: M-HHA002

## ANLAGE 2 ENCLOSURE 2

### Verwendungsbereich / Field of application

Die Fahrzeuge erfüllen - bezugnehmend auf ihre Fahrzeugtypgenehmigung - die Umweltaanforderungsstufen:  
*The vehicles fulfill - regarding their Whole Vehicle Type Approval (WVTA) - the environmental steps:*

Euro (5/5+)  
 Euro (5/5+)

Lfd. Nr.	Hersteller	Fabrikmarke	Handelsbezeichnung	Fahrzeugtyp ab Genehmigung Nr.	Var. Vers.	Motor typ 4-Takt	Hubraum in cm <sup>3</sup>	Nennleistung kW/min <sup>-1</sup>	Sonstige bestimmende Merkmale	Anordnung entspr. Anl. 1 lfd. Nr.
No. of vehicle	Manufacturer	Trade mark	Commercial description	Vehicle type beginning with no. of homologation	Var. Vers.	Engine type 4-Stroke	Engine capacity in cm <sup>3</sup>	max. engine power kW/min <sup>-1</sup>	Additional remarks	Composition reg. enclosure no. 1
1)	KTM (A)	KTM	KTM 1290 Super Adventure	KTM V2 Adventure	A1 / -	619	1301	118/9000	mit Kat. / with cat. *)	1)2a)
2)			KTM 1290 Super Adventure S	e1*168/2013*00274*	B1 / -					
3)			KTM 1290 Super Adventure R		C1 / -					
4)			KTM 1390 Super Adventure S	KTM V2 ADV	A / -	A626	1350	127/9500		
5)			KTM 1390 Super Adventure S EVO	e1*168/2013*00403*	B / -					
6)			KTM 1390 Super Adventure R		C / -					

\*) Der serienmäßige Katalysator bleibt unverändert im Abgassystem. Eine Verschlechterung des Abgasverhaltens ist nicht zu erwarten. /  
*The original catalytic converter remains in the exhaust system. A degradation of catalyst efficiency is not expected.*

M-HHA002\_ECE\_2.docx



Prüfbericht Nr. / Test report No.: 25-00068-CM-GBM-00  
 Hersteller / Manufacturer: Akrapovič, d.d., SLO-1295 Ivancna Gorica  
 Typ / Type: M-HHA002

## ANLAGE 3 ENCLOSURE 3

### Ergebnisse der Geräusch- und Leistungsmessungen – Versuchsreihe A / Results of noise testing and power measurements – Series A

Lfd. Nr. Fahrzeug	Leistung		Leistung Austausch kW/min <sup>-1</sup>	V <sub>max</sub>		V <sub>max</sub> Aus- tausch km/h	Fahrgeräusch in dB(A) / Sound level driving vehicle in dB(A) <sup>2)</sup>				Standgeräusch in dB(A) / Sound level stationary vehicle in dB(A) <sup>2)</sup>			
	Serie kW/min <sup>-1</sup>	Serie km/h		Serie km/h	V <sub>max</sub> original km/h		V <sub>max</sub> non original km/h	gemessen in Gang	Grenz- wert <sup>1)</sup>	Serie gemes- sen	Austausch gemessen	bei km/h	lt. Fzg. BE	Serie gemes- sen
No. of vehicle	Engine power original kW/min <sup>-1</sup>	Engine power non-original kW/min <sup>-1</sup>	Engine power non-original kW/min <sup>-1</sup>	V <sub>max</sub> original km/h	V <sub>max</sub> non original km/h	measured in gear ratio	Limit value <sup>1)</sup>	original/ mea- sured L <sub>Urban</sub>	non- original measured L <sub>Urban</sub>	at km/h	Vehicle type hom.	original mea- sured	non- original measured	at min <sup>-1</sup>
3) A:	118/9000	118/9000	118/9000	-	-	4	77	77,6	77,6	50	89	91	91	4500

<sup>1)</sup> Grenzwert der Richtlinienfassung, die bei Erteilung der Fahrzeuggenehmigung Gültigkeit hatte. /  
 Limit value of directive which was valid by vehicle type homologation.

<sup>2)</sup> Betriebsart / Operating mode: Rally

Prüfbericht Nr. / Test report No.: 25-00068-CM-GBM-00  
 Hersteller / Manufacturer: Akrapovič, d.d., SLO-1295 Ivanačna Gorica  
 Typ / Type: M-HHA002

## ANLAGE 3 ENCLOSURE 3

### Prüfbedingungen / Test conditions

Masse im fahrbereiten Zustand / Vehicle kerb weight	$m_{kerb}$ in kg	240
Testgewicht / Test weight	$m_t$ in kg	315
Fahrzeug- bzw. Bezugslänge / Length of vehicle / reference	$l_{veh}$ / $l_{ref}$ in m	2,25
Leistungsgewicht / Power to mass ratio	<b>PMR</b> in kW/t	374,6
Referenzbeschleunigung / Reference acceleration	$a_{wot\ ref}$ in $m/s^2$	4,41
Sollbeschleunigung / Target acceleration	$a_{urban}$ in $m/s^2$	2,10
Länge Vorbeschleunigung / Length of pre-acceleration	$l_{pa}$ in m	0
Benutzter Gang / Tested gear	-	4
Teillastfaktor / Partial load factor	$k_p$	0,492 / 0,510
Ganggewichtungsfaktor / Gear weight factor	$k$	-

## ANLAGE 3 ENCLOSURE 3

### Ergebnis der Prüfungen – Seriensystem – Versuchsreihe A / Test results - Original system – Series A

#### Messungen und Berechnung der Vorbeifahrtmessung / Tests and calculation passby noise level

Gang / Stufe / Gear / Position	Beschl. Vorbeifahrt / Accel. driving noise level			Konstante Vorbeifahrt / Constant driving noise level			
	w <sub>otest</sub> (l) links / left dB(A)	rechts / right dB(A)	a <sub>wotest</sub> (l) m/s <sup>2</sup>	cr <sub>test</sub> (l) links / left dB(A)	rechts / right dB(A)	a <sub>act test</sub> (l)	V P-P' km/h
4	83,0	81,9	4,32	72,4	71,0	-	49,4
4	83,0	81,5	4,30	72,9	71,8	-	49,4
4	83,0	81,4	4,25	71,9	72,0	-	50,0

#### Vorbeifahrtmessung Endergebnis / Passby noise level final result

L <sub>wot rep</sub> dB(A)	83,0	L <sub>ors rep</sub> dB(A)	72,4
L <sub>urban</sub> dB(A)	77,6	Grenzwert / Limit value dB(A)	77

#### Standgeräusch / Stationary noise level

n = 4500 min <sup>-1</sup>	links / left dB(A)	rechts / right dB(A)	links / left dB(A)	rechts / right dB(A)	links / left dB(A)	rechts / right dB(A)
Test 1	-	91,3	-	91,0	-	91,0
Test 2	-	90,5	-	90,9	-	91,0
Test 3	-	91,0	-	90,9	-	90,8
Mode	Rally					
Ergebnis / Result	91					
n = 4500 min <sup>-1</sup>	links / left dB(A)	rechts / right dB(A)	links / left dB(A)	rechts / right dB(A)	Street	
Test 1	-	91,0	-	91,2	91	
Test 2	-	91,5	-	91,3	91	
Test 3	-	91,7	-	91,3	91	
Mode	Offroad					
Ergebnis / Result	91					

## ANLAGE 3 ENCLOSURE 3

### Ergebnis der Prüfungen - Austauschsystem – Versuchsreihe A / Test results - Replacement system – Series A

#### Messungen und Berechnung der Vorbeifahrtmessung / Tests and calculation passby noise level

Gang / Stufe / Gear / Position	Beschl. Vorbeifahrt / Accel. driving noise level			Konstante Vorbeifahrt / Constant driving noise level			
	w <sub>otest</sub> (l) links / left dB(A)	rechts / right dB(A)	a <sub>wotest</sub> (l) m/s <sup>2</sup>	cr <sub>test</sub> (l) links / left dB(A)	rechts / right dB(A)	a <sub>act test</sub> (l)	V P,P' km/h
4	82,4	82,6	4,17	72,4	72,1	-	49,2
4	82,4	82,8	4,14	72,2	72,2	-	49,2
4	82,3	82,7	4,07	72,7	71,8	-	49,4

#### Vorbeifahrtmessung Endergebnis / Passby noise level final result

L <sub>wot rep</sub> dB(A)	82,7	L <sub>ors rep</sub> dB(A)	72,4
L <sub>urban</sub> dB(A)	77,6	Grenzwert / Limit value dB(A)	77

#### Standgeräusch / Stationary noise level

n = 4500 min <sup>-1</sup>	links / left dB(A)	rechts / right dB(A)	links / left dB(A)	rechts / right dB(A)	links / left dB(A)	rechts / right dB(A)
Test 1	-	91,0	-	90,6	-	90,6
Test 2	-	90,7	-	90,5	-	90,6
Test 3	-	91,3	-	90,3	-	91,0
Mode	Rally					
Ergebnis / Result	91		91		Street	
n = 4500 min <sup>-1</sup>	links / left dB(A)	rechts / right dB(A)	links / left dB(A)	rechts / right dB(A)		
Test 1	-	90,7	-	90,4		
Test 2	-	90,6	-	90,5		
Test 3	-	90,6	-	90,0		
Mode	Offroad					
Ergebnis / Result	91		90			



Prüfbericht Nr. / Test report No.: 25-00068-CM-GBM-00  
 Hersteller / Manufacturer: Akrapovič, d.d., SLO-1295 Ivancna Gorica  
 Typ / Type: M-HHA002

## ANLAGE 3 ENCLOSURE 3

### Ergebnisse der Geräusch- und Leistungsmessungen – Versuchsreihe B / Results of noise testing and power measurements – Series B

Lfd. Nr. Fahrzeug	Leistung		Leistung Austausch kW/min <sup>-1</sup>	V <sub>max</sub> Serie km/h	V <sub>max</sub> Aus- tausch km/h	Fahrgeräusch in dB(A) / Sound level driving vehicle in dB(A) <sup>2)</sup>			Standgeräusch in dB(A) / Sound level stationary vehicle in dB(A) <sup>2)</sup>				
	Serie kW/min <sup>-1</sup>	Engine power original kW/min <sup>-1</sup>				gemessen in Gang	Grenz- wert <sup>1)</sup>	Serie gemes- sen	Austausch gemessen	bei km/h	It. Fzg. BE	Serie gemes- sen	Austausch gemessen
No. of vehicle	Engine power original kW/min <sup>-1</sup>	Engine power non-original kW/min <sup>-1</sup>	measured in gear ratio	V <sub>max</sub> original km/h	V <sub>max</sub> non original km/h	Limit value <sup>1)</sup>	original/ mea- sured L <sub>Urban</sub>	non- original measured L <sub>Urban</sub>	at km/h	Vehicle type hom.	original mea- sured	non- original measured	at min <sup>-1</sup>
5) B:	127/9500	127/9500	4	-	-	77 SLEU5	76,5 L <sub>Urban</sub>	76,9 L <sub>Urban</sub>	50	91	92	91	4750

<sup>1)</sup> Grenzwert der Richtlinienfassung, die bei Erteilung der Fahrzeuggenehmigung Gültigkeit hatte. /  
 Limit value of directive which was valid by vehicle type homologation.

<sup>2)</sup> Betriebsart / Operating mode: Sport

Prüfbericht Nr. / Test report No.: 25-00068-CM-GBM-00  
 Hersteller / Manufacturer: Akrapovič, d.d., SLO-1295 Ivanačna Gorica  
 Typ / Type: M-HHA002

## ANLAGE 3 ENCLOSURE 3

### Prüfbedingungen / Test conditions

Masse im fahrbereiten Zustand / Vehicle kerb weight	$m_{kerb}$ in kg	260
Testgewicht / Test weight	$m_t$ in kg	335
Fahrzeug- bzw. Bezugslänge / Length of vehicle / reference	$l_{veh}$ / $l_{ref}$ in m	2,35
Leistungsgewicht / Power to mass ratio	<b>PMR</b> in kW/t	379,1
Referenzbeschleunigung / Reference acceleration	$a_{wot\ ref}$ in $m/s^2$	4,43
Sollbeschleunigung / Target acceleration	$a_{urban}$ in $m/s^2$	2,11
Länge Vorbeschleunigung / Length of pre-acceleration	$l_{pa}$ in m	0
Benutzter Gang / Tested gear	-	4
Teillastfaktor / Partial load factor	$k_p$	0,549 / 0,553
Ganggewichtungsfaktor / Gear weight factor	$k$	-

## ANLAGE 3 ENCLOSURE 3

### Ergebnis der Prüfungen – Seriensystem – Versuchsreihe B / Test results - Original system – Series B

#### Messungen und Berechnung der Vorbeifahrtmessung / Tests and calculation passby noise level

Gang / Stufe / Gear / Position	Beschl. Vorbeifahrt / Accel. driving noise level			Konstante Vorbeifahrt / Constant driving noise level				
	wot <sub>test</sub> (l) links / left dB(A)	rechts / right dB(A)	a <sub>wot, test</sub> (l) m/s <sup>2</sup>	V P,P' km/h	cr <sub>test</sub> (l) links / left dB(A)	rechts / right dB(A)	a <sub>act test</sub> (l)	V P,P' km/h
4	80,7	80,2	4,75	50,6	72,0	72,8	-	50,9
4	80,3	80,6	4,54	50,2	71,4	73,1	-	50,5
4	80,4	80,9	4,75	50,3	71,0	73,5	-	50,8

#### Vorbeifahrtmessung Endergebnis / Passby noise level final result

L <sub>wot rep</sub> dB(A)	80,6	L <sub>ors rep</sub> dB(A)	73,1
L <sub>urban</sub> dB(A)	76,5	Grenzwert / Limit value dB(A)	77

#### Standgeräusch / Stationary noise level

n = 4750 min <sup>-1</sup>	links / left dB(A)	rechts / right dB(A)	links / left dB(A)	rechts / right dB(A)	links / left dB(A)	rechts / right dB(A)
Test 1	-	91,5	-	91,6	-	91,4
Test 2	-	91,4	-	91,4	-	91,7
Test 3	-	91,6	-	91,2	-	91,6
Mode	Sport					
Ergebnis / Result	92			91		
	Street					
	92					

## ANLAGE 3 ENCLOSURE 3

### Ergebnis der Prüfungen - Austauschsystem – Versuchsreihe B / Test results - Replacement system – Series B

#### Messungen und Berechnung der Vorbeifahrtmessung / Tests and calculation passby noise level

Gang / Stufe / Gear / Position	Beschl. Vorbeifahrt / Accel. driving noise level			Konstante Vorbeifahrt / Constant driving noise level			
	w <sub>otest</sub> (l) links / left dB(A)	rechts / right dB(A)	a <sub>wotest</sub> (l) m/s <sup>2</sup>	cr <sub>test</sub> (l) links / left dB(A)	rechts / right dB(A)	a <sub>act test</sub> (l)	V P,P' km/h
4	81,9	82,3	4,75	72,3	72,7	-	50,2
4	82,1	82,0	4,55	72,6	72,7	-	49,5
4	82,3	82,3	4,86	72,9	72,4	-	49,5

#### Vorbeifahrtmessung Endergebnis / Passby noise level final result

L <sub>wot rep</sub> dB(A)	82,2	L <sub>ors rep</sub> dB(A)	72,6
L <sub>urban</sub> dB(A)	76,9	Grenzwert / Limit value dB(A)	77

#### Standgeräusch / Stationary noise level

n = 4750 min <sup>-1</sup>	links / left dB(A)	rechts / right dB(A)	links / left dB(A)	rechts / right dB(A)	links / left dB(A)	rechts / right dB(A)
Test 1	-	91,1	-	91,0	-	90,9
Test 2	-	91,3	-	91,2	-	91,0
Test 3	-	91,1	-	90,6	-	91,0
Mode	Sport					
Ergebnis / Result	91			91		
	Street					
	91					

M-HHA002\_ECE\_3.docx

**Information Document M-HHA002**

**relating to EU type-approval of a noise-abatement device as a STU**

TÜV SÜD Auto Service Technical Report: 25-00068-CM-GBM-00

Item No.	(Sub) categories	Detailed information
B.		<b>General information concerning systems, components, or separate technical units</b>
0.7.	L1e — L7e	<b>Make(s) (trade name(s) of manufacturer):</b> AKRAPOVIČ
0.8.	L1e — L7e	<b>Type:</b> <b>M-HHA002</b>
0.8.1.	L1e — L7e	Commercial name(s) (if available): n.a.
0.8.2.	L1e — L7e	Type-approval number(s) (if available): E26 92R-02 8224*00
0.8.3.	L1e — L7e	Type-approval(s) issued on (date, if available): n.a.
0.9.	L1e — L7e	<b>Company name and address of manufacturer:</b> Akrapovic d.d. Malo Hudo 8a SLO-1295 Ivančna Gorica
0.9.1.	L1e — L7e	Name(s) and address(es) of assembly plants: Akrapovič, d.d. Malo Hudo 8a SLO-1295 Ivančna Gorica  Akrapovič d.d., PE Ulica heroja Stariha 24 SLO-8340 Črnomelj
0.9.2.	L1e — L7e	Name and address of manufacturer's authorized representative, if any: n.a.
0.10.		<b>Vehicle(s) for which the system/separate technical unit is intended for:</b>
0.10.1.	L1e — L7e	Type: see Technical Report
0.10.2.	L1e — L7e	Variant: see Technical Report
0.10.3.	L1e — L7e	Version: see Technical Report
0.10.4.	L1e — L7e	Commercial name(s) (if available): see Technical Report
0.10.5.	L1e — L7e	Category, subcategory and sub-subcategory of vehicle: see Technical Report
C.		<b>General information concerning vehicle, systems, components, or separate technical units</b>
0.12.		<b>Conformity of production</b>
0.12.1.	L1e — L7e	Controlled by ISO 9001:2008 Quality Management System certified by TÜV SÜD Management Service GmbH Registration no.: 12 100/104 31148 TMS
1.		<b>GENERAL CONSTRUCTION CHARACTERISTICS</b>
1.8.		<b>Propulsion unit performance</b>
1.8.1.	L3e, L4e, L5e, L7e-A, L7e-B2	Declared maximum vehicle speed: km/h see Technical Report
1.8.2.	L1e, L2e, L6e, L7e-B1, L7e-C	Maximum design vehicle speed: ..... and gear in which it is reached: n.a.
1.8.3.	L1e — L7e	Maximum net power combustion engine: . kW at . min <sup>-1</sup> at A/F ratio: see Technical Report
1.8.4.	L1e — L7e	Maximum net torque combustion engine: . Nm at . min <sup>-1</sup> at A/F ratio: see Technical Report
1.8.5.	L1e — L7e	Maximum continuous-rated power electric motor (15/30 minutes power): n.a.
1.8.6.	L1e — L7e	Maximum continuous-rated torque electric motor: ..... Nm at .... min <sup>-1</sup> n.a.
1.8.7.	L1e — L7e	Maximum continuous total power for propulsion(s): .... kW. at .... min <sup>-1</sup> at A/F ratio: n.a.
1.8.8.	L1e — L7e	Maximum continuous total torque for propulsion(s): .... Nm at .... min <sup>-1</sup> at A/F ratio: n.a.
1.8.9.	L1e — L7e	Maximum peak power for propulsion(s): ..... kW at .... min <sup>-1</sup> at A/F ratio: n.a.

**Information Document M-HHA002**

**relating to EU type-approval of a noise-abatement device as a STU**

TÜV SÜD Auto Service Technical Report: 25-00068-CM-GBM-00

4.		<b>GENERAL INFORMATION ON ENVIRONMENTAL AND PROPULSION UNIT PERFORMANCE</b>
4.0		<b>General information on environmental and propulsion performance</b>
4.0.1.	L1e — L7e	Environmental step: Euro (5/5+)
4.0.2.	L1e — L7e	Fuel consumption: see WVTA
4.0.3.	L1e — L7e	CO <sub>2</sub> emissions: see WVTA
4.0.4.	L1e — L7e	Energy consumption: n.a.
4.0.5.	L1e — L7e	Electric range: n.a.
4.0.6.		Sound level
4.0.6.1.	L1e — L7e	Limit value for L <sub>urban</sub> : see Technical Report
4.4.	L1e — L7e	<b>Additional information on environmental and propulsion unit performance</b>
4.4.4.	L1e — L7e	All additional technical informations according to UN Regulation No. 92, are mentioned in the Technical Report or shown in the attachments.

Anlage / Enclosure	Dokument-Nr. / Document no.	Datum / Date	Seiten / Pages
Zeichnung Gesamtanlage / Drawing exhaust system	-	-	1
Zeichnung(en) der Bauteil(e) der zu genehmigenden techn. Einheit / Drawing(s) of the part(s) of the separate techn. unit	133249-HOM	26.08.2025	1
Stückliste / Part list	M-HHA002	-	1
Einbauanleitung / Mounting instructions	KTM 1390 KTM 1290	-	12
ASEP-Erklärung / ASEP Statement	-	26.08.2025	1

  
Davorin Dobočnik, CEO

08.09.2025

**Partial exhaust system / Slip-ON line / EC / ECE Type approval**

- KTM 1390 Super Adventure S EVO**
- KTM 1390 Super Adventure R**
- KTM 1290 Super Adventure**
- KTM 1290 Super Adventure S**
- KTM 1290 Super Adventure R**

**Product code: S-KTM12SO5-HHAT**

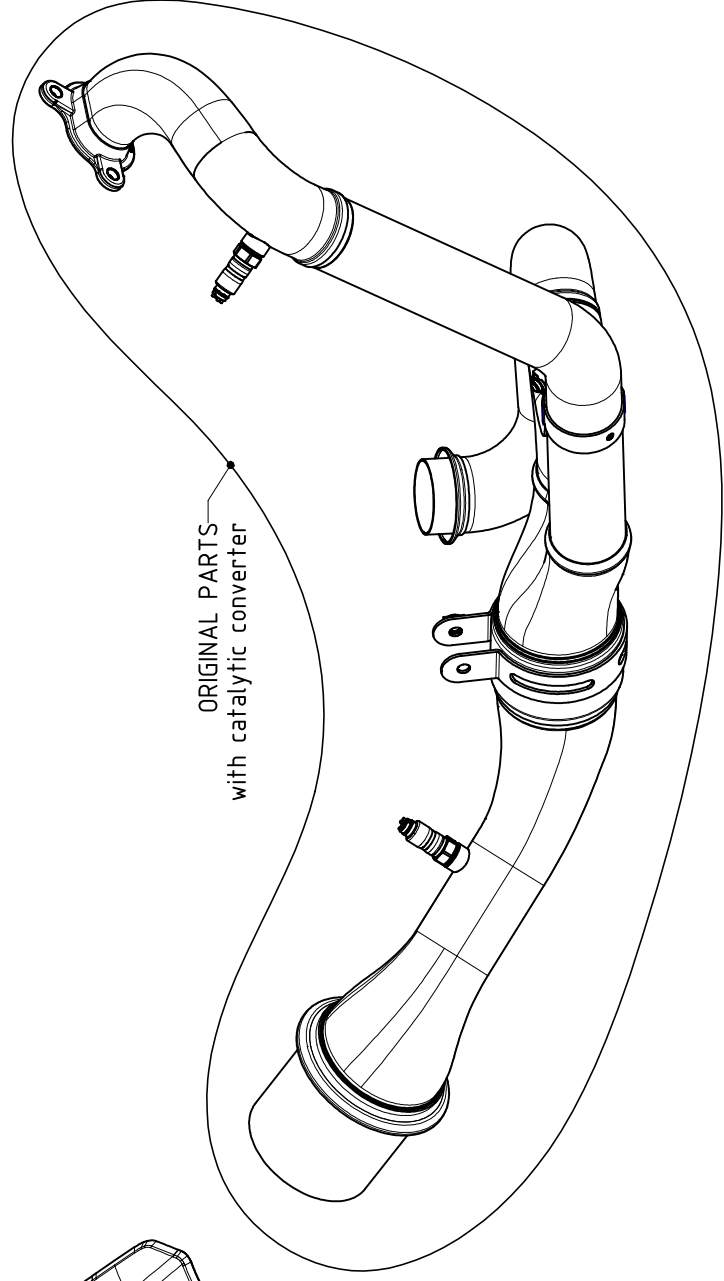
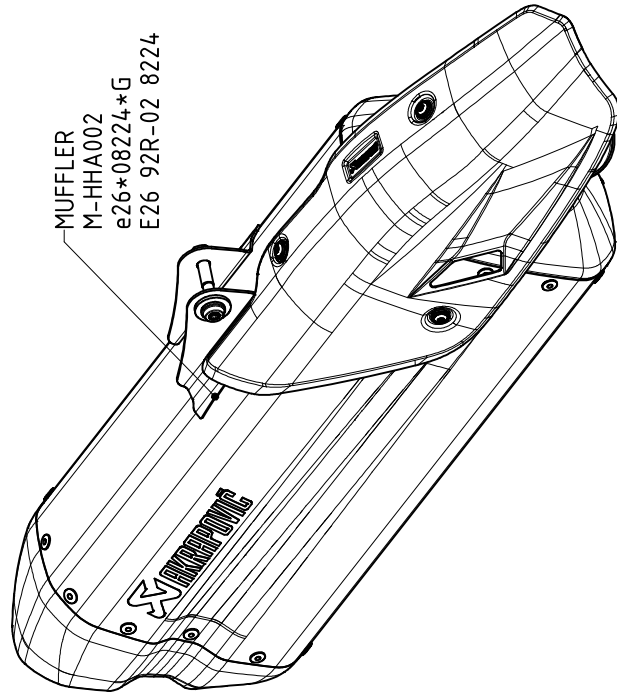

## Statement of compliance with the Additional Sound Emission Provisions

This statement is required for non-original replacement exhaust silencing systems (NORESS) without multiple, manually or electronically adjustable, rider selectable operating modes or without variable geometries specified for the use on L3 Category vehicles that are type approved pursuant to the amendments to UN Regulation No.41 and are subject to the ASEP-requirements series of amendments to UN Regulation No.41.

Akrapovič d.d., Malo Hudo 8a, 1295 Ivančna Gorica, attests that the non-original replacement exhaust silencing systems of this type **M-HHA002, (E26 92R-02 8224)**, comply with the applicable ASEP requirements of UN Regulation No.41 during the type approval procedure and its production.

Akrapovič d.d., Malo Hudo 8a, 1295 Ivančna Gorica, makes this statement in good faith, after having performed an appropriate evaluation of the sound emission performance of the non-original replacement exhaust silencing system in accordance with the requirements of UN Regulation No.92 during the type approval procedure and its production.

Date: 26.08.2025

Akrapovič d.d.  
Davorin Dobočnik, CEO

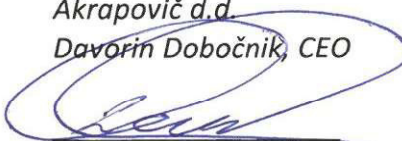

AKRAPOVIČ d.d.  
Malo Hudo 8a, 1295 Ivančna Gorica