



NSAI

EU TYPE-APPROVAL CERTIFICATE

Communication concerning: ~~EU type approval⁽¹⁾~~
~~Extension of EU type approval⁽¹⁾~~
~~Refusal of EU type approval⁽¹⁾~~
~~Withdrawal of EU type approval⁽¹⁾~~

of a type of ~~component~~/separate technical unit⁽¹⁾⁽⁰⁾ noise-abatement device
with regard to Annex(es) IX ^(a) to Commission Delegated Regulation (EU) No 134/2014 ~~(and Annex(es) ...^(a) to~~
~~Commission Delegated Regulation (EU) No .../...~~⁽¹⁾, as last amended by (Commission Delegated) ⁽¹⁾ Regulation (EU)
No 2018/295 ⁽¹⁾⁽⁶⁾

EU type-approval number⁽¹⁾: **e24*134/2014*2018/295/H*00306*01**

~~Reason for extension⁽¹⁾:~~ ***-Expansion of the area of application***
-Addition of exhaust tests stage 3

SECTION I

- 0.7. Make(s) (trade name(s) of manufacturer): **REMUS**
- 0.8. Type: **HX12**
- 0.8.1. Commercial name(s) (if available): **N/A**
- 0.9. Company name and address of the manufacturer: **Remus Innovation GmbH**
Ruhmannstraße 11
8570 Voitsberg
Austria
- 0.9.1. Name(s) and address(es) of assembly plant(s): **Remus Innovation Forschungs-**
und Abgasanlagen Produktions
GmbH
Dr. Niederdorferstraße 25
A-8572 Bärnbach
- Remus Innovation GmbH**
Ruhmannstraße 11
A-8570 Voitsberg
- 0.9.2. Name and address of the manufacturer's representative (if any): **N/A**
- 0.10. In the case of separate technical unit, vehicle(s) for which is intended for ^(b):
- 0.10.1. Type^(c) **See test report for details**
- 0.10.2. Variant(s)^(c): **See test report for details**
- 0.10.3. Version(s)^(c): **See test report for details**
- 0.10.4. Commercial name(s) (if available): **See test report for details**
- 0.10.5. Category, subcategory and sub-subcategory of vehicle (3): **L3e-A2, L3e-A3**

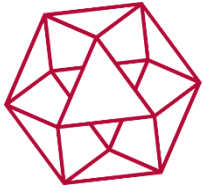

NSAI

EU type-approval number⁽¹⁾:

*e24*134/2014*2018/295/H*00306*01*

SECTION II

1. Technical service responsible for carrying out the tests:

***TÜV AUSTRIA
AUTOMOTIVE GMBH
Deutschstraße 10
A-1230 Wien***

2. Date of test report(s):

As before and 10.06.2022

3. Number of test report(s):

20-TAHO-142 up to/E1/SFLO

4. Remarks (see addendum):

N/A

5. Restrictions of validity ⁽¹⁾⁽⁴⁾:

N/A

6. Waivers applied ⁽¹⁾⁽⁴⁾:

N/A

Place:

Dublin

Date:

24th June, 2022

Name and signature (or visual representation of an ‘advanced electronic signature’ according to Directive 1999/93/EC, including data for verification):



Attachments:

- Information package
- Test report

NB:

— If this model is used for type-approval of a component or separate technical unit as an exemption for new technology or new concept, pursuant to Article 40 of Regulation (EU) No 168/2013, the heading of the certificate shall read ‘EU PROVISIONAL TYPE-APPROVAL CERTIFICATE VALID ONLY ON THE TERRITORY OF ... ⁽⁴⁾’, The provisional type approval certificate shall also specify the restrictions that have been imposed as to its validity and the waivers which have been applied in accordance with Article 30⁽⁴⁾ of Regulation (EU) No 168/2013.

Explanatory notes relating to Appendix 5

(Footnotes and explanations not to be stated on the type-approval certificate)

⁽⁰⁾ Indicate the component/separate technical unit according to first column of Table 1 in point 6 of Annex VII (e.g. devices to prevent unauthorised use)

⁽¹⁾ Delete where not applicable.

⁽³⁾ Classified according to Article 4 of and Annex I to Regulation (EU) No 168/2013, the coding shall be indicated, e.g. “L3e-A1E” for a low-performance Enduro motor-cycle.

⁽⁴⁾ Indicate the Member State.

⁽⁵⁾ Applicable only for type-approval of a component or separate technical unit as an exemption for new technology or new concept, pursuant to Article 40 of Regulation (EU) No 168/2013

⁽⁶⁾ Indicate the latest amendment of the Commission Delegated Regulation according to the amendment applied for the EU type-approval.

^(a) The Roman numeral of the relevant Annex to the Commission Delegated Regulation or multiple Roman numerals of the relevant Annexes to the same Commission Delegated Regulation.

^(b) Provide this information for each vehicle type.

^(c) Indicate the alphanumeric code Type-Variant-Version or ‘TVV’ allocated to each type, variant and version as set out in point 2.3 of Part B of Annex I.



ADDENDUM TO THE EU TYPE-APPROVAL CERTIFICATE WITH EU TYPE-APPROVAL NUMBER
*e24*134/2014*2018/295/H*00306*01*

- | | |
|--|--|
| 1. Restriction of use of the ⁽⁰⁾ (¹): | <i>Pollution control device and
Noise-abatement device</i> |
| (²): | <i>N/A</i> |
| 2. Special conditions for the mounting of the ⁽⁰⁾ (¹): | <i>Pollution control device and
Noise-abatement device</i> |
| (²): | <i>N/A</i> |
| 3. Remarks ⁽⁰⁾ : | <i>N/A</i> |

Explanatory notes relating to Appendix 6

(Footnotes and explanations not to be stated on the addendum to the type-approval certificate)

⁽⁰⁾ Delete where not applicable.

⁽¹⁾ Identify the component or separate technical unit according to the first column of Table 1 in point 6 of Annex VII to this Regulation (e.g. devices to prevent unauthorised use).

⁽²⁾ In accordance with Article 31(4) of Regulation (EU) No 168/2013, indicate the restrictions of use and the special conditions for the mounting of the component/separate technical unit.

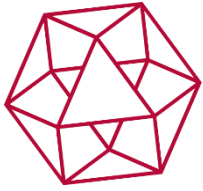

NSAI

EU type-approval number:

*e24*134/2014*2018/295/H*00306*01*

Index to the Information Package

Date of issue:	<i>13th October, 2020</i>
Date of latest amendment:	<i>24th June, 2022</i>
Reason for extension/revision:	<i>N/A</i>
1. Additional conditions, and advisory notes on legal alternatives	
2. Test report(s)	
- numbers(s):	<i>20-TAHO-0142 up to /E1/SFLO</i>
- date of issue:	<i>11.09.2020</i>
- date of latest amendment:	<i>10.06.2022</i>
3. Information document	
- number(s):	<i>HX12 up to /01</i>
- date of issue:	<i>03.08.2020</i>
- date of latest amendment:	<i>11.04.2022</i>
Documentation:	<i>89 pages</i>



EU type-approval number:

*e24*134/2014*2018/295/H*00306*01*

Appendix: Additional conditions, and advisory notes on legal alternatives

A: Additional conditions:

1. The attached technical report, with any of its attachments, forms part of this Type Approval certificate.
2. Each type from series production shall be to the measurements specified in the attached drawings, and shall be manufactured only from the materials specified in the Approval documents.
3. Changes in the type are permitted only with the explicit permission of NSAI. Breaches of this requirement will lead to a withdrawal of the Type Approval, and in addition may be subject to criminal prosecution.
4. At regular intervals, any tests or associated checks prescribed by the applicable legislation to verify continued conformity with the approved type shall be carried out. The manufacturer shall demonstrate compliance with this by submitting to NSAI evidence of adequate arrangements and documented control plans for each type approved.
5. Any set of samples or test pieces showing evidence of non-conformity shall give rise to further sampling and testing and all steps shall be taken to restore conformity of production.
6. This Type Approval will expire when it is surrendered by the holder, or withdrawn by NSAI, or when the approved type no longer conforms to legal requirements. The recall of the Type Approval can be issued by NSAI when the conditions required for the issuing or continuation of the Type Approval are no longer current, or when the Approval holder is in breach of the duties attached to the Type Approval, or when it is established that the approved type no longer meets the requirements of traffic safety.
7. Changes in the company name, address or manufacturing site, as well as in any of the sales or other agents specified in the issuing of the approval must immediately be notified to NSAI.
8. The duties imposed by the issuing of this certificate are not transferable. The legal protection of third parties is not affected by this certificate.
9. When the manufacture or sale of the system, component or separate technical unit has not been started within one year of the date of issue of this certificate, then NSAI is to be informed. This requirement also applies when the manufacture or sale has been halted for more than one year, or when it ought to have been halted for more than one year. The initial commencement of manufacture or sale, or the resumption of manufacture or sale, shall then be notified to NSAI within one month of commencement or resumption.

B: Legal Options:

Any objection to the requirements set out in this certificate shall be made within one month of the date of issue. The objection shall be made, in writing, to NSAI in Dublin.

Hersteller : Remus Innovation GmbH
Manufacturer
Type : HX12
Type
Prüfgegenstand : Austauschschalldämpfer
Subject
replacement exhaust

Prüfbericht

Test Report

20-TAHO-0142/E1/SFLO

**Einheitliche Bedingungen für die Genehmigung eines Auspuffs
(emissionsmindernde Einrichtung und lärmindernde Einrichtung) als
selbstständige technische Einheit für Fahrzeuge der Klassen L1, L2, L3, L4 und L5**
*Uniform provisions concerning the approval of an exhaust (pollution-control and noise abatement device)
as a separate technical unit for motorcycles, mopeds and three-wheeled vehicles*

Gemäß Verordnung/Richtlinie According to Regulation/Directive	
<input checked="" type="checkbox"/>	VO (EU) 134/2014 Anhang I, Anhang II und Anhang IX Anlage 2 einschließlich aller Änderungen bis 2018/295 <i>Regulation (EU) 134/2014 Annex I, Annex II and Annex IX appendix 2 including amendments until 2018/295</i>

Genehmigungsstand approval status	
<input type="checkbox"/>	Erteilung einer Typgenehmigung <i>Granting of a type approval</i>
<input checked="" type="checkbox"/>	Erweiterung der Typgenehmigung e24*134/2014*2018/295H*00306*00 *) <i>Extension to a type approval e24*134/2014*2018/295H*00306*00</i>
<input type="checkbox"/>	Änderung zur Typgenehmigung *) <i>Correction of a type approval</i>

*Bemerkungen / Remarks
Erweiterung des Verwendungsbereichs und Abgasprüfung Phase 3 <i>Expansion of the area of application and exhaust tests stage 3</i>

Änderungen sind blau markiert
Changes are marked blue

Hersteller : Remus Innovation GmbH
Manufacturer
Type : HX12
Type
Prüfgegenstand : Austauschschalldämpfer
Subject : replacement exhaust

PBV-TAA-005 Rev. 00

0. Allgemeine Angaben

General information

- 0.1 Fabrikmarke : Remus
Trademark
- 0.2 Typ : HX12
Type
- 0.3 Varianten und Versionen : Siehe Beschreibungsbogen
Variants and Versions
See Information Document
- 0.4 Name und Anschrift des Herstellers : Remus Innovation GmbH
Name and address of manufacturer
Ruhmannstraße 11
A-8570 Voitsberg
- 0.5 Beschreibungsbogen Nr. : HX12/01
Information document No.
- 0.5.1 Ausgabedatum : 21.04.2022
Issue date

1. Verwendungsbereich : Siehe Anlage 1
Range of application
See Annex 1

2. Angaben zum Prüfobjekt : Siehe Beschreibungsbogen
Details of the test subject
See Information Document

- 2.1 Art des Ersatzschalldämpfers : Siehe Beschreibungsbogen gemäß Punkt 0.5
Type of replacement muffler
see Information Document according to 0.5
- 2.2 Lage, Anzahl und Richtung des Endrohre : Fahrzeugende hinten, rechts
Position, number and direction of the tail pipe(s)
Rear side of the vehicle, right

3. Prüfprotokoll

Test protocol

Die Prüfungen wurden mit folgendem(n) : Fahrzeug Nr. #1
Fahrzeug(en) durchgeführt #2
Test have been carried out with the following vehicle(s) Vehicle number #7
#8
#13
#14

Verwendeter Austauschschalldämpfer : Remus / HX12
Muffler used

Hersteller : Remus Innovation GmbH
Manufacturer
Type : HX12
Type
Prüfgegenstand : Austauschschalldämpfer
Subject replacement exhaust

PBV-TAA-005 Rev. 00

3.1 Fahrzeug #1 Vehicle #1

3.1.1.1 Hersteller : Husqvarna
Manufacturer
3.1.1.2 Typ : Husqvarna 701
Type
3.1.1.3 Variante/Version : A / -
Variant/Version
3.1.1.4 Genehmigungsnummer : e1*168/2013*00032*..
Homologation no.
3.1.1.5 Fahrzeugidentifizierungsnummer : VBKUSVP35MM781894
Vehicle identification number
3.1.1.6 Baujahr : 2020
Year of manufacture
3.1.1.7 Kilometerstand : 1114
Mileage (km)

3.1.2 Antriebsaggregat Engine

3.1.2.1 Hersteller : KTM AG
Manufacturer
3.1.2.2 Typ : 768
Type
3.1.2.3 Nennleistung [kW @ min-1] : 55 @ 8000
Rated maximum engine power
3.1.2.4 Hubraum [cm³] : 693
Cubic capacity

3.1.3 Kraftübertragung Transmission

3.1.3.1 Technische Zeichnung des Kraftübertragungssystems : Siehe Fahrzeugtypgenehmigung gemäß 3.1.4
Tech. Drawing of the power transmission system See WVTA according to 3.1.4
3.1.3.2 Art der Kraftübertragung : mechanisch / mechanic
Type of power transmission hydraulisch / hydraulic
 elektrisch / electric

Hersteller : Remus Innovation GmbH
Manufacturer
Type : HX12
Type
Prüfgegenstand : Austauschschalldämpfer
Subject
replacment exhaust

PBV-TAA-005 Rev. 00

3.1.3.3 Art des Getriebes : mechanisch / mechanic
Type of gearbox automatisch / automatic
 stufenlos / CVT

3.1.3.4 Getriebeübersetzungen

Gear ratios

Primär

I : 2,5

primary

II : 1,75

III : 1,35

IV : 1,095

V : 0,957

VI : 0,87

Sekundär

Antriebsübersetzung 2,63

secondary

Final drive ratio

3.1.3.5 Höchstgeschwindigkeit [km/h] : 200

Maximum speed

3.1.4 Bereifung

Mounted wheels

Achse 1

: 120/70 R17 M/C 58H

Axle 1

Achse 2

: 160/60 R17 M/C 69H

Axle 2

Hersteller : Remus Innovation GmbH
Manufacturer
Type : HX12
Type
Prüfgegenstand : Austauschschalldämpfer
Subject : replacement exhaust

3.2 Fahrzeug #2 Vehicle #2

3.2.1.1 Hersteller : Husqvarna
Manufacturer
3.2.1.2 Typ : Husqvarna 701
Type
3.2.1.3 Variante/Version : A / -
Variant/Version
3.2.1.4 Genehmigungsnummer : e1*168/2013*00034*..
Homologation no.
3.2.1.5 Fahrzeugidentifizierungsnummer : VBKUSVP35MM781894
Vehicle identification number
3.2.1.6 Baujahr : 2020
Year of manufacture
3.2.1.7 Kilometerstand : 1223
Mileage (km)

3.2.2 Antriebsaggregat Engine

3.2.2.1 Hersteller : KTM AG
Manufacturer
3.2.2.2 Typ : 768
Type
3.2.2.3 Nennleistung [kW @ min-1] : 31 @ 7000
Rated maximum engine power
3.2.2.4 Hubraum [cm³] : 693
Cubic capacity

3.2.3 Kraftübertragung Transmission

3.2.3.1 Technische Zeichnung des Kraftübertragungssystems : Siehe Fahrzeugtypgenehmigung gemäß 3.1.4
Tech. Drawing of the power transmission system See WVTA according to 3.1.4
3.2.3.2 Art der Kraftübertragung : mechanisch / mechanic
Type of power transmission hydraulisch / hydraulic
 elektrisch / electric

Hersteller : Remus Innovation GmbH
Manufacturer
Type : HX12
Type
Prüfgegenstand : Austauschschalldämpfer
Subject : replacement exhaust

PBV-TAA-005 Rev. 00

3.2.3.3 Art des Getriebes : mechanisch / mechanic
Type of gearbox automatisch / automatic
 stufenlos / CVT

3.2.3.4 Getriebeübersetzungen

Gear ratios

Primär

I : 2,5

primary

II : 1,75

III : 1,35

IV : 1,095

V : 0,957

VI : 0,87

Sekundär

Antriebsübersetzung 2,63

secondary

Final drive ratio

3.2.3.5 Höchstgeschwindigkeit [km/h] : 160

Maximum speed

3.2.4 Bereifung

Mounted wheels

Achse 1

: 120/70 R17 M/C 58H

Axle 1

Achse 2

: 160/60 R17 M/C 69H

Axle 2

Hersteller : Remus Innovation GmbH
Manufacturer
Type : HX12
Type
Prüfgegenstand : Austauschschalldämpfer
Subject : replacement exhaust

PBV-TAA-005 Rev. 00

3.3 Fahrzeug #7 Vehicle #7

3.3.1.1 Hersteller : KTM
Manufacturer
3.3.1.2 Typ : KTM 690 LC4
Type
3.3.1.3 Variante/Version : A / -
Variant/Version
3.3.1.4 Genehmigungsnummer : e1*168/2013*00147*..
Homologation no.
3.3.1.5 Fahrzeugidentifizierungsnummer : VBKLETP30MM777579
Vehicle identification number
3.3.1.6 Baujahr : 2020
Year of manufacture
3.3.1.7 Kilometerstand : 1690
Mileage (km)

3.3.2 Antriebsaggregat Engine

3.3.2.1 Hersteller : KTM AG
Manufacturer
3.3.2.2 Typ : 768
Type
3.3.2.3 Nennleistung [kW @ min-1] : 55 @ 8000
Rated maximum engine power
3.3.2.4 Hubraum [cm³] : 693
Cubic capacity

3.3.3 Kraftübertragung Transmission

3.3.3.1 Technische Zeichnung des Kraftübertragungssystems : Siehe Fahrzeugtypgenehmigung gemäß 3.1.4
Tech. Drawing of the power transmission system See WVTA according to 3.1.4
3.3.3.2 Art der Kraftübertragung : mechanisch / mechanic
Type of power transmission hydraulisch / hydraulic
 elektrisch / electric

Hersteller : Remus Innovation GmbH
Manufacturer
Type : HX12
Type
Prüfgegenstand : Austauschschalldämpfer
Subject
replacement exhaust

PBV-TAA-005 Rev. 00

3.3.3.3 Art des Getriebes : mechanisch / mechanic
Type of gearbox automatisch / automatic
 stufenlos / CVT

3.3.3.4 Getriebeübersetzungen

Gear ratios

Primär

I : 2,5

primary

II : 1,75

III : 1,35

IV : 1,095

V : 0,957

VI : 0,87

Sekundär

Antriebsübersetzung 3,07

secondary

Final drive ratio

3.3.3.5 Höchstgeschwindigkeit [km/h] : 180

Maximum speed

3.3.4 Bereifung

Mounted wheels

Achse 1

: 90/90 R21 M/C 54T

Axle 1

Achse 2

: 140/80 R18 M/C 70T

Axle 2

Hersteller : Remus Innovation GmbH
Manufacturer
Type : HX12
Type
Prüfgegenstand : Austauschschalldämpfer
Subject replacement exhaust

PBV-TAA-005 Rev. 00

3.4 Fahrzeug #8
Vehicle #8

- 3.4.1.1 Hersteller : KTM
Manufacturer
- 3.4.1.2 Typ : KTM 690 LC4
Type
- 3.4.1.3 Variante/Version : A / -
Variant/Version
- 3.4.1.4 Genehmigungsnummer : e1*168/2013*00146*..
Homologation no.
- 3.4.1.5 Fahrzeugidentifizierungsnummer : VBKLETP30MM777579
Vehicle identification number
- 3.4.1.6 Baujahr : 2020
Year of manufacture
- 3.4.1.7 Kilometerstand : 1786
Mileage (km)

3.4.2 Antriebsaggregat
Engine

- 3.4.2.1 Hersteller : KTM AG
Manufacturer
- 3.4.2.2 Typ : 768
Type
- 3.4.2.3 Nennleistung [kW @ min-1] : 31 @ 7000
Rated maximum engine power
- 3.4.2.4 Hubraum [cm³] : 693
Cubic capacity

3.4.3 Kraftübertragung
Transmission

- 3.4.3.1 Technische Zeichnung des Kraftübertragungssystems : Siehe Fahrzeugtypgenehmigung gemäß 3.1.4
Tech. Drawing of the power transmission system See WVTA according to 3.1.4
- 3.4.3.2 Art der Kraftübertragung : mechanisch / *mechanic*
 hydraulisch / *hydraulic*
 elektrisch / *electric*

Hersteller : Remus Innovation GmbH
Manufacturer
Type : HX12
Type
Prüfgegenstand : Austauschschalldämpfer
Subject
replacment exhaust

PBV-TAA-005 Rev. 00

3.4.3.3 Art des Getriebes : mechanisch / mechanic
Type of gearbox automatisch / automatic
 stufenlos / CVT

3.4.3.4 Getriebeübersetzungen

Gear ratios

Primär

I : 2,5

primary

II : 1,75

III : 1,35

IV : 1,095

V : 0,957

VI : 0,87

Sekundär

Antriebsübersetzung 3,07

secondary

Final drive ratio

3.4.3.5 Höchstgeschwindigkeit [km/h] : 160

Maximum speed

3.4.4 Bereifung

Mounted wheels

Achse 1

: 90/90 R21 M/C 54T

Axle 1

Achse 2

: 140/80 R18 M/C 70T

Axle 2

Hersteller : Remus Innovation GmbH
Manufacturer
Type : HX12
Type
Prüfgegenstand : Austauschschalldämpfer
Subject replacement exhaust

PBV-TAA-005 Rev. 00

3.5 Fahrzeug #13
Vehicle #13

3.5.1.1 Hersteller : KTM
Manufacturer

3.5.1.2 Typ : KTM 690 LC4
Type

3.5.1.3 Variante/Version : B / -
Variant/Version

3.5.1.4 Genehmigungsnummer : e1*168/2013*00147*..
Homologation no.

3.5.1.5 Fahrzeugidentifizierungsnummer : VBKLSTP38KM735473
Vehicle identification number

3.5.1.6 Baujahr : 2019
Year of manufacture

3.5.1.7 Kilometerstand : 1006
Mileage (km)

3.5.2 Antriebsaggregat
Engine

3.5.2.1 Hersteller : KTM AG
Manufacturer

3.5.2.2 Typ : 768
Type

3.5.2.3 Nennleistung [kW @ min-1] : 55 @ 8000
Rated maximum engine power

3.5.2.4 Hubraum [cm³] : 693
Cubic capacity

3.5.3 Kraftübertragung
Transmission

3.5.3.1 Technische Zeichnung des Kraftübertragungssystems : Siehe Fahrzeugtypgenehmigung gemäß 3.1.4
Tech. Drawing of the power transmission system See WVTA according to 3.1.4

3.5.3.2 Art der Kraftübertragung : mechanisch / *mechanic*
 hydraulisch / *hydraulic*
 elektrisch / *electric*

Hersteller : Remus Innovation GmbH
Manufacturer
Type : HX12
Type
Prüfgegenstand : Austauschschalldämpfer
Subject
replacement exhaust

PBV-TAA-005 Rev. 00

3.5.3.3 Art des Getriebes : mechanisch / mechanic
Type of gearbox automatisch / automatic
 stufenlos / CVT

3.5.3.4 Getriebeübersetzungen

Gear ratios

Primär

I : 2,5

primary

II : 1,75

III : 1,35

IV : 1,095

V : 0,957

VI : 0,87

Sekundär

Antriebsübersetzung 2,63

secondary

Final drive ratio

3.5.3.5 Höchstgeschwindigkeit [km/h] : 200

Maximum speed

3.5.4 Bereifung

Mounted wheels

Achse 1

: 120/70 R17 M/C 58W

Axle 1

Achse 2

: 160/60 R17 M/C 69W

Axle 2

Hersteller : Remus Innovation GmbH
Manufacturer
Type : HX12
Type
Prüfgegenstand : Austauschschalldämpfer
Subject replacement exhaust

PBV-TAA-005 Rev. 00

3.6.1 Fahrzeug #14
Vehicle #14

3.6.1.1 Hersteller : KTM
Manufacturer

3.6.1.2 Typ : KTM 690 LC4
Type

3.6.1.3 Variante/Version : A / -
Variant/Version

3.6.1.4 Genehmigungsnummer : e1*168/2013*00146*..
Homologation no.

3.6.1.5 Fahrzeugidentifizierungsnummer : VBKLSTP38KM735473
Vehicle identification number

3.6.1.6 Baujahr : 2019
Year of manufacture

3.6.1.7 Kilometerstand : 1145
Mileage (km)

3.6.2 Antriebsaggregat
Engine

3.6.2.1 Hersteller : KTM AG
Manufacturer

3.6.2.2 Typ : 768
Type

3.6.2.3 Nennleistung [kW @ min-1] : 32 @ 5500
Rated maximum engine power

3.6.2.4 Hubraum [cm³] : 693
Cubic capacity

3.6.3 Kraftübertragung
Transmission

3.6.3.1 Technische Zeichnung des Kraftübertragungssystems : Siehe Fahrzeugtypgenehmigung gemäß 3.1.4
Tech. Drawing of the power transmission system See WVTA according to 3.1.4

3.6.3.2 Art der Kraftübertragung : mechanisch / *mechanic*
 hydraulisch / *hydraulic*
 elektrisch / *electric*

Hersteller : Remus Innovation GmbH
Manufacturer
Type : HX12
Type
Prüfgegenstand : Austauschschalldämpfer
Subject
replacement exhaust

PBV-TAA-005 Rev. 00

3.6.3.3 Art des Getriebes : mechanisch / mechanic
Type of gearbox automatisch / automatic
 stufenlos / CVT

3.6.3.4 Getriebeübersetzungen

Gear ratios

Primär

I : 2,5

primary

II : 1,75

III : 1,35

IV : 1,095

V : 0,957

VI : 0,87

Sekundär

Antriebsübersetzung 2,63

secondary

Final drive ratio

3.6.3.5 Höchstgeschwindigkeit [km/h] : 150

Maximum speed

3.6.4 Bereifung

Mounted wheels

Achse 1

: 120/70 R17 M/C 58W

Axle 1

Achse 2

: 160/60 R17 M/C 69W

Axle 2

Hersteller : Remus Innovation GmbH
Manufacturer
Type : HX12
Type
Prüfgegenstand : Austauschschalldämpfer
Subject : replacement exhaust

PBV-TAA-005 Rev. 00

- 3.7 Zusammenbau der Abgasanlage** : Siehe Beschreibungsbogen
Assembly of the exhaust system See information document
- 3.8 Messung der Geräuschwerte**
Acoustic measurements
- 3.8.1 Hersteller der Messgeräte : NTI Audio
Manufacturer of measurement devices
- 3.8.2 Type der Messgeräte : XL2 TA
Make of measurement devices
- 3.8.3 Prüfverfahren für Fahrgeräusch : UNECE-R41.04
Testing procedure for driving sound level UNECE-R41.04
 VO(EU) 134/2014
Regulation (EU) 134/2014
- 3.8.4 Prüfverfahren für Standgeräusch : Siehe 3.6.3
Testing procedure for stationary vehicle sound level See 3.6.3
- 3.9 Messung des Abgasgedrucks**
Exhaust back pressure measurements
- 3.9.1 Hersteller des Messgerätes : WIKA
Manufacturer of measurement device
- 3.9.2 Type des Messgerätes : 909.40.500
Make of measurement device
- 3.9.3 Messmethode : Messung bei Volllast
Method of testing Measurement under full load
- 3.10 Konditionierung der Auspuffschalldämpferanlage** : Straßendauerlauf
Conditioning of exhaust gas silencing system Road permanent run

Hersteller : Remus Innovation GmbH
Manufacturer
Type : HX12
Type
Prüfgegenstand : Austauschschalldämpfer
Subject : replacement exhaust

4. Prüfergebnisse Testing results

- 4.1 Das Messwerte der durchgeführten Prüfungen sind der in Anlage 2 beigefügten Tabelle zu entnehmen.
The measured values of the tests carried out shall be taken from the table in Appendix 2.
- 4.2 Aufgrund eines Vergleiches der Geräuschpegel des beschriebenen Schalldämpfers mit denen des serienmäßigen Schalldämpfers sind beide Schalldämpfer als akustisch gleichwertig zu betrachten.
Due to a comparison of the noise level of the exhaust described with those of the standard exhaust, both exhaust systems are considered to be acoustically equivalent.
- 4.3 Aufgrund dessen sind die Messergebnisse sind für die in Anlage 1 aufgeführten Fahrzeuge und Motoren mit identischen Serienschalldämpfern, die gemäß den nachfolgend genannten Richtlinien geprüft und typgenehmigt wurden, stellvertretend.
As a result, the measurement results are representative of the vehicles and engines listed in Appendix 1 with identical series silencers that have been tested and type approved in accordance with the following guidelines.
- 4.4 Es ist sichergestellt, dass alle in Anlage 1 aufgeführten Fahrzeuge gemäß VO (EU) 134/2014 in der entsprechenden Fassung, bzw. ECE R41.04 typgenehmigt wurden.
It is ensured that all vehicles listed in Appendix 1 have been type-approved in accordance with VO (EU) 134/2014 as amended or ECE R41.04
- 4.5 Die Messergebnisse sind auf den unter Punkt 0.2 genannten Typ inklusiver aller beschriebenen Versionen und Varianten übertragbar.
The measurement results are transferable to the type mentioned under point 0.2 including all versions and variants described.
- 4.6 Die beschriebene technische Einheit darf an den in Anlage 1 aufgeführten Kraftfahrzeugen unter den dort genannten Bedingungen verwendet werden.
The described technical unit is suitable for an application at the vehicles named in annex 1 under the conditions specified therein.
- 4.7 Mit der gegenständlichen Schalldämpferanlage wurden die Abgasemissionen gemäß VO(EU) 134/2014 ermittelt. Die der Typengenehmigung zugrundeliegenden Grenzwerte wurden hierbei nicht überschritten.
The exhaust gas emissions of the complete exhaust system were determined in accordance with Regulation (EU) 134/2014. The limit values on which the type approval was based were not exceeded.

Hersteller : Remus Innovation GmbH
Manufacturer
Type : HX12
Type
Prüfgegenstand : Austauschschalldämpfer
Subject replacement exhaust

5. Anlagen Annexes

Anlage Annex	1	Verwendungsbereich Range of application	1	Seite(n) Page(s)
Anlage Annex	2	Prüfergebnisse Betriebsgeräusch Test results sound level	15	Seite(n) Page(s)
Anlage Annex	3	Prüfergebnisse Abgasemissionen Test results exhaust emissions	4	Seite(n) Page(s)
Anlage Annex	4	Informationsdokument (siehe 0.5) Information documents (acc. to 0.5)	51	Seite(n) Page(s)

6. Schlussbescheinigung Final statement

Der unter Punkt 0.5. angegebene Beschreibungsbogen und der darin beschriebene Typ entsprechen der oben genannten Prüfspezifikation. Der ungünstigste Fall wurde entsprechend Dokument (QAA-TAA-002_Auswahlverfahren für worst case) bestimmt.

The information document as mentioned under No. 0.5 and the type described therein are in compliance with the test specification mentioned above. The worst case was selected in accordance with document (QAA-TAA-002_Selection process for worst case).

Dieser Prüfbericht umfasst die Seiten 1 bis 7 und die unter Punkt 6 beschriebenen Anhänge. Der Prüfbericht darf nur vom Auftraggeber und nur in vollem Wortlaut vervielfältigt und weitergegeben werden. Eine auszugsweise Vervielfältigung und Veröffentlichung des Prüfberichtes ist nur nach schriftlicher Genehmigung des Prüflaboratoriums zulässig.

This report includes pages 1 to 17. The test report may be reproduced and published fully and by the client only.

Wien / Vienna, 10.06.2022

TÜV AUSTRIA AUTOMOTIVE GMBH



Benannter Technischer Dienst des Kraftfahrt-Bundesamtes (KBA), Registrier-Nummer KBA-P 00055-00

Designated Technical Service of Kraftfahrt-Bundesamt (KBA), Germany, Registration number KBA-P 00055-00



Benannter Technischer Dienst des National Standards Authority of Ireland (NSAI), Technical Service Number 103

Designated Technical Service by the National Standards Authority of Ireland (NSAI), Technical Service Number 103

Zeichnungsberechtigter

Approved signatory

Ing. Andreas Pfiel



Anhang / Annex 1: Verwendungsbereich / Range of application

Hersteller : Remus Innovation GmbH
 Manufacturer
 Type : HX12
 Type
 Prüfgegenstand : Austauschschalldämpfer
 Subject replacement exhaust

PBV-TAA-005 Rev. 00

Hersteller / Manufacturer		KTM AG								
Fzg. Nr. Vehicle	Handelsbezeichnung Trade name	Fahrzeugtype Vehicle type	Genehmigungs- nummer Approval no.	Fahrzeug klasse Category	Motortyp / Arbeitsprinzip Engine type / principle	Takt Stroke	Hubraum Capacity [cm ³]	Nennleistung Engine power [kW/min ⁻¹]	Anordnung Configuration	
#1	Husqvarna	Husqvarna 701	e1*168/2013*00032*..	L3e, A3	768	PI	4-Takt 4 stroke	693	55/8000	siehe Beschreibungs- bogen see information document
#2	Husqvarna	Husqvarna 701	e1*168/2013*00034*..	L3e, A2					31/7000	
#3	Husqvarna	Husqvarna 701	e1*168/2013*00032*..	L3e, A3					55/8000	
#4	Husqvarna	Husqvarna 701	e1*168/2013*00034*..	L3e, A2					31/7000	
#5	Husqvarna	Husqvarna 701	e1*168/2013*00032*..	L3e, A3					55/8000	
#6	Husqvarna	Husqvarna 701	e1*168/2013*00034*..	L3e, A2					31/7000	
#7	KTM	KTM 690 LC4	e1*168/2013*00147*..	L3e, A3					55/8000	
#8	KTM	KTM 690 LC4	e1*168/2013*00146*..	L3e, A2					31/7000	
#9	KTM	KTM 690 LC4	e1*168/2013*00147*..	L3e, A3					55/8000	
#10	KTM	KTM 690 LC4	e1*168/2013*00146*..	L3e, A2					31/7000	
#11	KTM	KTM 690 LC4	e1*168/2013*00147*..	L3e, A3					55/8000	
#12	KTM	KTM 690 LC4	e1*168/2013*00146*..	L3e, A2					32/5500	
#13	KTM	KTM 690 LC4	e1*168/2013*00147*..	L3e, A3					55/8000	
#14	KTM	KTM 690 LC4	e1*168/2013*00146*..	L3e, A2					32/5500	

Anhang / Annex 1: Verwendungsbereich / Range of application

Hersteller : Remus Innovation GmbH
 Manufacturer
 Type : HX12
 Type
 Prüfgegenstand : Austauschschalldämpfer
 Subject replacement exhaust

PBV-TAA-005 Rev. 00

Hersteller / Manufacturer		KTM AG								
Fzg. Nr. Vehicle	Handelsbezeichnung Trade name	Fahrzeugtype Vehicle type	Genehmigungs- nummer Approval no.	Fahrzeug klasse Category	Motortyp / Arbeitsprinzip Engine type / principle		Takt Stroke	Hubraum Capacity [cm ³]	Nennleistung Engine power [kW/min ⁻¹]	Anordnung Configuration
#15	GasGas ES 700	GG LC4	e1*168/2013*00298*00	L3e, A3	768	PI	4-Takt 4 stroke	693	55 / 8000	siehe Beschreibungs- bogen see information document
#16	GasGas SM 700	GG LC4	e1*168/2013*00298*00	L3e, A3					55 / 8000	
#17	GasGas ES 700	GG LC4	e1*168/2013*00307*00	L3e, A2					31 / 7000	
#18	GasGas SM 700	GG LC4	e1*168/2013*00307*00	L3e, A2					31 / 7000	

Aktenzeichen / File number
20-TAHO-0142/E1/SFLO

Anhang / Annex 2: Prüfergebnisse Betriebsgeräusch / Test results sound level

Hersteller : Remus Innovation GmbH

Manufacturer

Type : HX12

Type

Prüfgegenstand : Austauschschalldämpfer

Subject replacement exhaust

TÜV AUSTRIA AUTOMOTIVE GMBH
Deutschstraße 10
A-1230 Wien
www.tuv.at



PBV-TAA-005 Rev. 00

Fahrzeug-Nr. / Vehicle-No.	#1
FIN / VIN	VBKUSVP35MM781894
Variante / Version / Variant / Version	A / --
Power to Mass Ratio index (PMR) [-]	238,10
l_{ref} [m]	2,18
Testmasse / test mass (mt) [kg]	231
$a_{urban\ ref}$ [m/s ²]	1,85
$a_{wot\ ref}$ [m/s ²]	3,75
Teillastfaktor / Partial power factor kp [-]	0,482

Umgebungsbedingungen / meteorological data	
Temperatur / Temperature	15,1 [°C]
Luftdruck / Air pressure	980 [hPa]
Windgeschwindigkeit / Wind speed	2,2 [m/s]
Luftfeuchtigkeit / Humidity	45,1 [%]
Umgebungsgeräusch / Ambient noise	48,7 [dB(A)]

Messergebnisse im Detail - Fahrgeräusch / measurement results in detail – moving sound level

$L_{wot, 3^{rd}\ gear\ V_{pp}=50km/h}$	vAA (km/h)	vPP (km/h)	vBB (km/h)	$A_{wot\ AA-BB}\ (m/s^2)$	$L_{wot\ left}\ (dB(A))$	$L_{wot\ right}\ (dB(A))$	$L_{wot\ Max}\ [dB(A)]$
1.Test	39,8	50,3	60,0	3,51	80,2	78,7	
2.Test	39,9	51,0	61,1	3,72	79,6	79,9	
3.Test	40,9	50,6	60,7	3,50	80,6	79,1	
Average / Mittelwert	40,2	50,6	60,6	3,58	80,1	79,2	80,1

$L_{crs, 3^{rd}\ gear\ 50km/h}$	vAA (km/h)	vPP (km/h)	vBB (km/h)	$L_{crs\ left}\ (dB(A))$	$L_{crs\ right}\ (dB(A))$	$L_{crs\ Max}\ [dB(A)]$
1.Test	50,9	50,5	50,0	71,0	70,6	
2.Test	49,4	49,7	49,6	71,8	70,1	
3.Test	49,9	50,4	50,2	71,4	71,2	
Average / Mittelwert	50,1	50,2	49,9	71,4	70,6	71,4

L_{urban}		$L_{urban}\ [dB(A)]$
Schalldruckpegel L_{urban} Sound pressure level L_{urban}	$L_{urban} = L_{wot} - kp * (L_{wot} - L_{crs})$	75,9

Aktenzeichen / File number
20-TAHO-0142/E1/SFLO

Anhang / Annex 2: Prüfergebnisse Betriebsgeräusch / Test results sound level

Hersteller : Remus Innovation GmbH

Manufacturer

Type : HX12

Type

Prüfgegenstand : Austauschschalldämpfer

Subject replacement exhaust

TÜV AUSTRIA AUTOMOTIVE GMBH
Deutschstraße 10
A-1230 Wien
www.tuv.at



PBV-TAA-005 Rev. 00

Messergebnisse im Detail – Standgeräusch / measurement results in detail – stationary sound level

Standgeräusch <i>Stationary Sound Level</i>	LHS / links [dB(A)]	RHS / rechts [dB(A)]	Prüfdrehzahl [min ⁻¹] <i>Target Engine Speed [min-1]</i>
1.Test	90,4	--	4000
2.Test	89,8	--	
3.Test	90,3	--	
Prüfergebnis <i>Test result</i>	90	--	

Aktenzeichen / File number
20-TAHO-0142/E1/SFLO

Anhang / Annex 2: Prüfergebnisse Betriebsgeräusch / Test results sound level

Hersteller : Remus Innovation GmbH

Manufacturer

Type : HX12

Type

Prüfgegenstand : Austauschschalldämpfer

Subject replacement exhaust

TÜV AUSTRIA AUTOMOTIVE GMBH
Deutschstraße 10
A-1230 Wien
www.tuv.at



PBV-TAA-005 Rev. 00

Fahrzeug-Nr. / Vehicle-No.	#2
FIN / VIN	VBKUSVP35MM781894
Variante / Version / Variant / Version	A / --
Power to Mass Ratio index (PMR) [-]	134,20
l_{ref} [m]	2,18
Testmasse / test mass (mt) [kg]	231
$a_{urban\ ref}$ [m/s ²]	1,53
$a_{wot\ ref}$ [m/s ²]	2,93
Teillastfaktor / Partial power factor k_p [-]	0,422

Umgebungsbedingungen / meteorological data	
Temperatur / Temperature	16,5 [°C]
Luftdruck / Air pressure	981,5 [hPa]
Windgeschwindigkeit / Wind speed	0,8 [m/s]
Luftfeuchtigkeit / Humidity	45,1 [%]
Umgebungsgeräusch / Ambient noise	48,8 [dB(A)]

Messergebnisse im Detail - Fahrgeräusch / measurement results in detail – moving sound level

$L_{wot, 4^{th}\ gear\ V_{pp}=50km/h}$	vAA (km/h)	vPP (km/h)	vBB (km/h)	$A_{wot\ AA-BB}$ (m/s ²)	$L_{wot\ left}$ (dB(A))	$L_{wot\ right}$ (dB(A))	$L_{wot\ Max}$ [dB(A)]
1.Test	43,2	50,4	58,2	2,65	79,3	78,8	
2.Test	42,6	50,6	58,1	2,71	79,0	78,4	
3.Test	43,5	50,1	58,2	2,60	79,3	78,7	
Average / Mittelwert	43,1	50,4	58,2	2,65	79,2	78,6	

$L_{crs, 4^{th}\ gear\ 50km/h}$	vAA (km/h)	vPP (km/h)	vBB (km/h)	$L_{crs\ left}$ (dB(A))	$L_{crs\ right}$ (dB(A))	$L_{crs\ Max}$ [dB(A)]
1.Test	50,6	50,4	50,3	71,4	70,4	
2.Test	49,4	49,6	50,1	71,3	70,3	
3.Test	50,4	50,4	50,7	71,6	71,1	
Average / Mittelwert	50,1	50,1	50,4	71,4	70,6	

L_{urban}		L_{urban} [dB(A)]
Schalldruckpegel L_{urban} Sound pressure level L_{urban}	$L_{urban} = L_{wot} - k_p * (L_{wot} - L_{crs})$	75,9

Aktenzeichen / File number
20-TAHO-0142/E1/SFLO

Anhang / Annex 2: Prüfergebnisse Betriebsgeräusch / Test results sound level

Hersteller : Remus Innovation GmbH

Manufacturer

Type : HX12

Type

Prüfgegenstand : Austauschschalldämpfer

Subject replacement exhaust

TÜV AUSTRIA AUTOMOTIVE GMBH
Deutschstraße 10
A-1230 Wien
www.tuv.at



PBV-TAA-005 Rev. 00

Messergebnisse im Detail – Standgeräusch / measurement results in detail – stationary sound level

Standgeräusch <i>Stationary Sound Level</i>	LHS / links [dB(A)]	RHS / rechts [dB(A)]	Prüfdrehzahl [min ⁻¹] <i>Target Engine Speed [min-1]</i>
1.Test	88,0	--	3500
2.Test	88,3	--	
3.Test	87,8	--	
Prüfergebnis <i>Test result</i>	88	--	

Aktenzeichen / File number
20-TAHO-0142/E1/SFLO

Anhang / Annex 2: Prüfergebnisse Betriebsgeräusch / Test results sound level

Hersteller : Remus Innovation GmbH

Manufacturer

Type : HX12

Type

Prüfgegenstand : Austauschschalldämpfer

Subject replacement exhaust

TÜV AUSTRIA AUTOMOTIVE GMBH
Deutschstraße 10
A-1230 Wien
www.tuv.at



PBV-TAA-005 Rev. 00

Fahrzeug-Nr. / Vehicle-No.	#7
FIN / VIN	VBKLETP30MM777579
Variante / Version / Variant / Version	A / --
Power to Mass Ratio index (PMR) [-]	234,04
l_{ref} [m]	2,18
Testmasse / test mass (mt) [kg]	235
$a_{urban\ ref}$ [m/s ²]	1,84
$a_{wot\ ref}$ [m/s ²]	3,73
Teillastfaktor / Partial power factor k_p [-]	0,515

Umgebungsbedingungen / meteorological data	
Temperatur / Temperature	14,4 [°C]
Luftdruck / Air pressure	980 [hPa]
Windgeschwindigkeit / Wind speed	3,1 [m/s]
Luftfeuchtigkeit / Humidity	48,5 [%]
Umgebungsgeräusch / Ambient noise	52,1 [dB(A)]

Messergebnisse im Detail - Fahrgeräusch / measurement results in detail – moving sound level

$L_{wot, 3^{rd}\ gear\ V_{pp}=50km/h}$	vAA (km/h)	vPP (km/h)	vBB (km/h)	$A_{wot\ AA-BB}\ (m/s^2)$	$L_{wot\ left}\ (dB(A))$	$L_{wot\ right}\ (dB(A))$	$L_{wot\ Max}\ [dB(A)]$
1.Test	38,9	50,1	61,0	3,84	81,7	80,8	
2.Test	39,1	50,5	60,2	3,64	81,1	81,2	
3.Test	38,3	49,9	61,0	3,92	81,3	81,0	
Average / Mittelwert	38,8	50,2	60,7	3,80	81,4	81,0	

$L_{crs, 3^{rd}\ gear\ 50km/h}$	vAA (km/h)	vPP (km/h)	vBB (km/h)	$L_{crs\ left}\ (dB(A))$	$L_{crs\ right}\ (dB(A))$	$L_{crs\ Max}\ [dB(A)]$
1.Test	50,0	50,0	49,6	73,1	71,4	
2.Test	49,6	49,6	49,6	73,0	72,4	
3.Test	50,1	50,0	49,4	72,6	71,4	
Average / Mittelwert	49,9	49,9	49,5	72,9	71,7	

L_{urban}		$L_{urban}\ [dB(A)]$
Schalldruckpegel L_{urban} Sound pressure level L_{urban}	$L_{urban} = L_{wot} - k_p * (L_{wot} - L_{crs})$	77,0

Aktenzeichen / File number
20-TAHO-0142/E1/SFLO

Anhang / Annex 2: Prüfergebnisse Betriebsgeräusch / Test results sound level

Hersteller : Remus Innovation GmbH

Manufacturer

Type : HX12

Type

Prüfgegenstand : Austauschschalldämpfer

Subject replacement exhaust

TÜV AUSTRIA AUTOMOTIVE GMBH
Deutschstraße 10
A-1230 Wien
www.tuv.at



PBV-TAA-005 Rev. 00

Messergebnisse im Detail – Standgeräusch / measurement results in detail – stationary sound level

Standgeräusch <i>Stationary Sound Level</i>	LHS / links [dB(A)]	RHS / rechts [dB(A)]	Prüfdrehzahl [min ⁻¹] <i>Target Engine Speed [min-1]</i>
1.Test	90,4	--	4000
2.Test	90,0	--	
3.Test	90,1	--	
Prüfergebnis <i>Test result</i>	90	--	

Aktenzeichen / File number
20-TAHO-0142/E1/SFLO

Anhang / Annex 2: Prüfergebnisse Betriebsgeräusch / Test results sound level

Hersteller : Remus Innovation GmbH

Manufacturer

Type : HX12

Type

Prüfgegenstand : Austauschschalldämpfer

Subject replacement exhaust

TÜV AUSTRIA AUTOMOTIVE GMBH
Deutschstraße 10
A-1230 Wien
www.tuv.at



PBV-TAA-005 Rev. 00

Fahrzeug-Nr. / Vehicle-No.	#8
FIN / VIN	VBKLETP30MM777579
Variante / Version / Variant / Version	A / --
Power to Mass Ratio index (PMR) [-]	131,91
l_{ref} [m]	2,18
Testmasse / test mass (mt) [kg]	235
$a_{urban\ ref}$ [m/s ²]	1,52
$a_{wot\ ref}$ [m/s ²]	2,90
Teillastfaktor / Partial power factor k_p [-]	0,504

Umgebungsbedingungen / meteorological data	
Temperatur / Temperature	20,1 [°C]
Luftdruck / Air pressure	981 [hPa]
Windgeschwindigkeit / Wind speed	2,4 [m/s]
Luftfeuchtigkeit / Humidity	28,3 [%]
Umgebungsgeräusch / Ambient noise	47,2 [dB(A)]

Messergebnisse im Detail - Fahrgeräusch / measurement results in detail – moving sound level

$L_{wot, 4^{th}\ gear\ V_{pp}=50km/h}$	vAA (km/h)	vPP (km/h)	vBB (km/h)	$A_{wot\ AA-BB}$ (m/s ²)	$L_{wot\ left}$ (dB(A))	$L_{wot\ right}$ (dB(A))	$L_{wot\ Max}$ [dB(A)]
1.Test	42,9	50,8	60,2	3,10	81,6	80,7	
2.Test	42,0	50,3	59,2	3,03	81,6	79,5	
3.Test	42,8	51,0	60,1	3,10	81,2	80,5	
Average / Mittelwert	42,6	50,7	59,8	3,08	81,5	80,2	

$L_{crs, 4^{th}\ gear\ 50km/h}$	vAA (km/h)	vPP (km/h)	vBB (km/h)	$L_{crs\ left}$ (dB(A))	$L_{crs\ right}$ (dB(A))	$L_{crs\ Max}$ [dB(A)]
1.Test	50,3	50,0	50,1	72,1	71,4	
2.Test	50,4	50,9	50,3	73,2	70,6	
3.Test	50,2	50,4	49,9	72,4	71,4	
Average / Mittelwert	50,3	50,4	50,1	72,6	71,1	

L_{urban}		L_{urban} [dB(A)]
Schalldruckpegel L_{urban} Sound pressure level L_{urban}	$L_{urban} = L_{wot} - k_p * (L_{wot} - L_{crs})$	77,0

Aktenzeichen / File number
20-TAHO-0142/E1/SFLO

Anhang / Annex 2: Prüfergebnisse Betriebsgeräusch / Test results sound level

Hersteller : Remus Innovation GmbH

Manufacturer

Type : HX12

Type

Prüfgegenstand : Austauschschalldämpfer

Subject replacement exhaust

TÜV AUSTRIA AUTOMOTIVE GMBH
Deutschstraße 10
A-1230 Wien
www.tuv.at



PBV-TAA-005 Rev. 00

Messergebnisse im Detail – Standgeräusch / measurement results in detail – stationary sound level

Standgeräusch <i>Stationary Sound Level</i>	LHS / links [dB(A)]	RHS / rechts [dB(A)]	Prüfdrehzahl [min ⁻¹] <i>Target Engine Speed [min-1]</i>
1.Test	88,1	--	3500
2.Test	88,3	--	
3.Test	88,0	--	
Prüfergebnis <i>Test result</i>	88	--	

Aktenzeichen / File number
20-TAHO-0142/E1/SFLO

Anhang / Annex 2: Prüfergebnisse Betriebsgeräusch / Test results sound level

Hersteller : Remus Innovation GmbH

Manufacturer

Type : HX12

Type

Prüfgegenstand : Austauschschalldämpfer

Subject replacement exhaust

TÜV AUSTRIA AUTOMOTIVE GMBH
Deutschstraße 10
A-1230 Wien
www.tuv.at



PBV-TAA-005 Rev. 00

Fahrzeug-Nr. / Vehicle-No.	#13
FIN / VIN	VBKLSTP38KM735473
Variante / Version / Variant / Version	B / --
Power to Mass Ratio index (PMR) [-]	234,04
l_{ref} [m]	2,18
Testmasse / test mass (mt) [kg]	235
$a_{urban\ ref}$ [m/s ²]	1,84
$a_{wot\ ref}$ [m/s ²]	3,73
Teillastfaktor / Partial power factor kp [-]	0,514

Umgebungsbedingungen / meteorological data	
Temperatur / Temperature	15,8 [°C]
Luftdruck / Air pressure	980 [hPa]
Windgeschwindigkeit / Wind speed	2,6 [m/s]
Luftfeuchtigkeit / Humidity	43,8 [%]
Umgebungsgeräusch / Ambient noise	47,3 [dB(A)]

Messergebnisse im Detail - Fahrgeräusch / measurement results in detail – moving sound level

$L_{wot, 3^{rd}\ gear\ V_{pp}=50km/h}$	vAA (km/h)	vPP (km/h)	vBB (km/h)	$A_{wot\ AA-BB}\ (m/s^2)$	$L_{wot\ left}\ (dB(A))$	$L_{wot\ right}\ (dB(A))$	$L_{wot\ Max}\ [dB(A)]$
1.Test	39,0	50,0	60,5	3,72	80,9	79,3	
2.Test	38,3	50,2	60,9	3,90	80,8	79,9	
3.Test	38,4	49,5	60,3	3,76	81,3	79,5	
Average / Mittelwert	38,6	49,9	60,6	3,79	81,0	79,6	81,0

$L_{crs, 3^{rd}\ gear\ 50km/h}$	vAA (km/h)	vPP (km/h)	vBB (km/h)	$L_{crs\ left}\ (dB(A))$	$L_{crs\ right}\ (dB(A))$	$L_{crs\ Max}\ [dB(A)]$
1.Test	49,9	49,6	49,7	71,7	70,0	
2.Test	50,4	49,9	49,8	71,1	70,0	
3.Test	50,0	49,8	49,7	71,0	70,4	
Average / Mittelwert	50,1	49,8	49,7	71,3	70,1	71,3

L_{urban}		$L_{urban}\ [dB(A)]$
Schalldruckpegel L_{urban} Sound pressure level L_{urban}	$L_{urban} = L_{wot} - kp * (L_{wot} - L_{crs})$	76,0

Aktenzeichen / File number
20-TAHO-0142/E1/SFLO

Anhang / Annex 2: Prüfergebnisse Betriebsgeräusch / Test results sound level

Hersteller : Remus Innovation GmbH

Manufacturer

Type : HX12

Type

Prüfgegenstand : Austauschschalldämpfer

Subject replacement exhaust

TÜV AUSTRIA AUTOMOTIVE GMBH
Deutschstraße 10
A-1230 Wien
www.tuv.at



PBV-TAA-005 Rev. 00

Messergebnisse im Detail – Standgeräusch / measurement results in detail – stationary sound level

Standgeräusch <i>Stationary Sound Level</i>	LHS / links [dB(A)]	RHS / rechts [dB(A)]	Prüfdrehzahl [min ⁻¹] <i>Target Engine Speed [min-1]</i>
1.Test	90,5	--	4000
2.Test	90,1	--	
3.Test	90,4	--	
Prüfergebnis <i>Test result</i>	90	--	

Aktenzeichen / File number
20-TAHO-0142/E1/SFLO

Anhang / Annex 2: Prüfergebnisse Betriebsgeräusch / Test results sound level

Hersteller : Remus Innovation GmbH

Manufacturer

Type : HX12

Type

Prüfgegenstand : Austauschschalldämpfer

Subject replacement exhaust

TÜV AUSTRIA AUTOMOTIVE GMBH
Deutschstraße 10
A-1230 Wien
www.tuv.at



PBV-TAA-005 Rev. 00

Fahrzeug-Nr. / Vehicle-No.	#14
FIN / VIN	VBKLSTP38KM735473
Variante / Version / Variant / Version	A / --
Power to Mass Ratio index (PMR) [-]	136,17
l_{ref} [m]	2,18
Testmasse / test mass (mt) [kg]	235
$a_{urban\ ref}$ [m/s ²]	1,54
$a_{wot\ ref}$ [m/s ²]	2,95
Teillastfaktor / Partial power factor kp [-]	0,441

Umgebungsbedingungen / meteorological data	
Temperatur / Temperature	15,2 [°C]
Luftdruck / Air pressure	980 [hPa]
Windgeschwindigkeit / Wind speed	2,8 [m/s]
Luftfeuchtigkeit / Humidity	45,6 [%]
Umgebungsgeräusch / Ambient noise	51,1 [dB(A)]

Messergebnisse im Detail - Fahrgeräusch / measurement results in detail – moving sound level

$L_{wot, 3^{rd}\ gear\ V_{pp}=50km/h}$	vAA (km/h)	vPP (km/h)	vBB (km/h)	$A_{wot\ AA-BB}\ (m/s^2)$	$L_{wot\ left}\ (dB(A))$	$L_{wot\ right}\ (dB(A))$	$L_{wot\ Max}\ [dB(A)]$
1.Test	42,7	49,6	58,6	2,80	80,8	79,1	
2.Test	42,6	49,5	57,7	2,63	80,6	79,8	
3.Test	42,2	49,8	58,4	2,83	80,4	80,2	
Average / Mittelwert	42,5	49,6	58,2	2,76	80,6	79,7	

$L_{crs, 3^{rd}\ gear\ 50km/h}$	vAA (km/h)	vPP (km/h)	vBB (km/h)	$L_{crs\ left}\ (dB(A))$	$L_{crs\ right}\ (dB(A))$	$L_{crs\ Max}\ [dB(A)]$
1.Test	49,6	49,7	49,9	72,4	71,5	
2.Test	50,2	49,9	50,1	72,2	71,3	
3.Test	50,2	49,7	49,3	72,1	71,2	
Average / Mittelwert	50,0	49,8	49,8	72,2	71,3	

L_{urban}		$L_{urban}\ [dB(A)]$
Schalldruckpegel L_{urban} Sound pressure level L_{urban}	$L_{urban} = L_{wot} - kp * (L_{wot} - L_{crs})$	76,9

Aktenzeichen / File number
20-TAHO-0142/E1/SFLO

Anhang / Annex 2: Prüfergebnisse Betriebsgeräusch / Test results sound level

Hersteller : Remus Innovation GmbH

Manufacturer

Type : HX12

Type

Prüfgegenstand : Austauschschalldämpfer

Subject replacement exhaust

TÜV AUSTRIA AUTOMOTIVE GMBH
Deutschstraße 10
A-1230 Wien
www.tuv.at



PBV-TAA-005 Rev. 00

Messergebnisse im Detail – Standgeräusch / measurement results in detail – stationary sound level

Standgeräusch <i>Stationary Sound Level</i>	LHS / links [dB(A)]	RHS / rechts [dB(A)]	Prüfdrehzahl [min ⁻¹] <i>Target Engine Speed [min-1]</i>
1.Test	87,8	--	2750
2.Test	87,5	--	
3.Test	87,7	--	
Prüfergebnis <i>Test result</i>	88	--	

Aktenzeichen / File number
20-TAHO-0142/E1/SFLO

Anhang / Annex 2: Prüfergebnisse Betriebsgeräusch / Test results sound level

Hersteller : Remus Innovation GmbH

Manufacturer

Type : HX12

Type

Prüfgegenstand : Austauschschalldämpfer

Subject replacement exhaust

TÜV AUSTRIA AUTOMOTIVE GMBH
Deutschstraße 10
A-1230 Wien
www.tuv.at



PBV-TAA-005 Rev. 00

Übersicht Messergebnisse / Overview test data

Fahrzeug Nr. Vehicle No.	Geräuschwerte Sound level values							
	Fahrgeräusch L _{Urban} Moving vehicle					Standgeräusch Stationary vehicle		
	Gang Gear	WVTA [dB(A)]	OEM _{gemessen} OEM _{measured} [dB(A)]	Austausch- schalldämpfer Replacement exhaust [dB(A)]	Grenzwert ¹⁾ Limit ¹⁾ [dB(A)]	WVTA [dB(A)]	OEM _{gemessen} OEM _{measured} [dB(A)@min ⁻¹]	Austausch- schalldämpfer Replacement exhaust [dB(A)@min ⁻¹]
#1	3	76	76,7	75,9	77	90	91/4000	90/4000
#2	4	76	76,3	75,9	77	89	88/3500	88/3500
#7	3	77	77,8	77,0	77	90	90/4000	90/4000
#8	4	77	76,9	77,0	77	89	89/3500	88/3500
#13	3	76	76,3	77,0	77	91	90/4000	90/4000
#14	4	77	77,4	76,9	77	88	87/2750	88/2750

¹⁾ Grenzwert lt. Richtlinie od. Verordnung der Fahrzeugtypgenehmigung

^{*)} limit value of directive which was valid when vehicle type approval was issued

Übersicht ASEP / Overview ASEP

Fahrzeug Nr.: #1 Vehicle No.:		nAA' (min ⁻¹)	VAA' (km/h)	nPP' (min ⁻¹)	VPP' (km/h)	nBB' (min ⁻¹)	VBB' (km/h)	ASEP noise level [dB(A)]	ASEP noise limit [dB(A)]
1.st ref.	3 th gear	2772	40,5	3450	50,7	4080	60,5	82,1	84,3
2nd ref.	3 th gear	4005	59,8	4517	66,9	5065	75,0	85,2	89,5
1.add	4 th gear	2481	44,9	2866	52,3	3251	59,8	81,2	83,7
2nd add.	4 th gear	2720	49,6	3120	56,4	3465	63,7	81,8	83,9

Fahrzeug Nr.: #2 Vehicle No.:		nAA' (min ⁻¹)	VAA' (km/h)	nPP' (min ⁻¹)	VPP' (km/h)	nBB' (min ⁻¹)	VBB' (km/h)	ASEP noise level [dB(A)]	ASEP noise limit [dB(A)]
1.st ref.	4 th gear	2398	43,0	2772	50,4	3166	58,1	81,3	83,2
2nd ref.	3 th gear	2881	41,7	3524	52,0	4206	62,0	82,5	86,9
1.add	3 th gear	2384	34,9	3173	46,5	3894	57,6	81,9	85,2
2nd add.	4 th gear	2738	49,3	3105	56,2	3471	63,3	82,5	84,8

Fahrzeug Nr.: #7 Vehicle No.:		nAA' (min ⁻¹)	VAA' (km/h)	nPP' (min ⁻¹)	VPP' (km/h)	nBB' (min ⁻¹)	VBB' (km/h)	ASEP noise level [dB(A)]	ASEP noise limit [dB(A)]
1.st ref.	3 th gear	2993	38,9	3779	50,3	4537	60,3	82,0	84,9
2nd ref.	3 th gear	3698	48,8	4378	57,9	5146	67,7	85,6	87,8
1.add	4 th gear	2479	40,7	3147	47,7	3441	56,9	82,1	84,3
2nd add.	4 th gear	3086	50	3617	57,5	3923	64,7	82,7	84,7

Fahrzeug Nr.: #8 Vehicle No.:		nAA' (min ⁻¹)	VAA' (km/h)	nPP' (min ⁻¹)	VPP' (km/h)	nBB' (min ⁻¹)	VBB' (km/h)	ASEP noise level [dB(A)]	ASEP noise limit [dB(A)]
1.st ref.	4 th gear	2644	42,3	3115	50,8	3663	59,8	81,8	84,5
2nd ref.	3 th gear	2227	27,5	3193	42,2	4147	54,9	82,1	84,9
1.add	4 th gear	2758	44,6	3253	53,1	3748	61,7	82,3	85,2
2nd add.	4 th gear	3064	49,7	3546	57,6	4006	65,4	83,0	86,7

Anhang / Annex 2: Prüfergebnisse Betriebsgeräusch / Test results sound level

Hersteller : Remus Innovation GmbH

Manufacturer

Type : HX12

Type

Prüfgegenstand : Austauschschalldämpfer

Subject replacement exhaust

Fahrzeug Nr.: #13 Vehicle No.:		nAA' (min ⁻¹)	VAA' (km/h)	nPP' (min ⁻¹)	VPP' (km/h)	nBB' (min ⁻¹)	VBB' (km/h)	ASEP noise level [dB(A)]	ASEP noise limit [dB(A)]
1.st ref.	3 th gear	2682	38,2	3404	49,7	4127	60,6	81,8	85,1
2nd ref.	3 th gear	3990	58,2	4523	66,4	5137	75,4	86,2	90,7
1.add	4 th gear	2519	45,0	2918	51,9	3335	60,4	81,9	84,5
2nd add.	4 th gear	2792	50,1	3179	57,0	3567	64,7	82,8	84,8

Fahrzeug Nr.: #14 Vehicle No.:		nAA' (min ⁻¹)	VAA' (km/h)	nPP' (min ⁻¹)	VPP' (km/h)	nBB' (min ⁻¹)	VBB' (km/h)	ASEP noise level [dB(A)]	ASEP noise limit [dB(A)]
1.st ref.	4 th gear	2394	43,0	2807	50,1	3253	58,8	82,1	84,6
2nd ref.	3 th gear	2782	40,6	3499	51,4	4215	61,8	82,9	88,0
1.add	3 th gear	2503	35,8	3302	47,2	4024	58,7	82,5	87,0
2nd add.	4 th gear	2759	49,5	3167	56,8	3558	64,6	82,6	86,4

Aktenzeichen / File number
20-TAHO-0142/E1/SFLO

Anhang / Annex 3: Prüfergebnisse Abgasemissionen / Test results exhaust emissions

Hersteller : Remus Innovation GmbH

Manufacturer

Type : HX12

Type

Prüfgegenstand : Austauschschalldämpfer

Subject replacement exhaust

TÜV AUSTRIA AUTOMOTIVE GMBH
Deutschstraße 10
A-1230 Wien
www.tuv.at



PBV-TAA-005 Rev. 00

Fahrzeug-Nr. / Vehicle-No.	#13
FIN / VIN	VBKLSTP38KM735473
Variante / Version / Variant / Version	B / -
Nenn Drehzahl / rated engine speed [min ⁻¹]	8000
Leerlaufdrehzahl / idling engine speed [min ⁻¹]	1400
Kraftstoff / fuel	Gasoline (E5)
Fahrzeugmasse / vehicle mass [kg]	160
Schwungmasse / inertia mass [kg]	230
f ₀ / f ₂ [N / N/(km/h) ²]	20,2 / 0,0235

Umgebungsbedingungen / meteorological data	
Temperatur / Temperature	22,5 [°C]
Luftdruck / Air pressure	978 [hPa]
Luftfeuchtigkeit / Humidity	27,8 [%]

Messergebnisse / test data

Fahrzeug Nr. Vehicle No.	Abgasemissionen gemäß VO(EU) 134/2014*2016/1824 (WMTC Phase 2 / 3-2 – EURO 4) Exhaust emissions according to Regulation (EU) 134/2014*2016/1824 (WMTC Class 2 / 3-2 – EURO 4)								
	Type I Test					Type II Test			
	Abgaskomponente Exhaust component	Ergebnis Test [mg/km]	DF	Endergebnis Final result [mg/km]	Grenzwert ^{*)} Limit ^{*)} [mg/km]	Abgaskomponente Exhaust component	RPM	Endergebnis Final result [Vol%]	Grenzwert ^{*)} Limit ^{*)} [Vol%]
#13	CO	721	1,3	937	1140	CO Leerlauf normal CO idle	1400	0,0155	0,5
	HC	85	1,2	102	170	CO Leerlauf hoch CO high idle	2500	0,0123	0,3
	NO _x	29	1,2	34	90				

^{*)} Grenzwert lt. Richtlinie od. Verordnung der Fahrzeugtypgenehmigung

^{*)} limit value of directive which was valid when vehicle type approval was issued

Aktenzeichen / File number
20-TAHO-0142/E1/SFLO

Anhang / Annex 3: Prüfergebnisse Abgasemissionen / Test results exhaust emissions

Hersteller : Remus Innovation GmbH

Manufacturer

Type : HX12

Type

Prüfgegenstand : Austauschschalldämpfer

Subject replacement exhaust

TÜV AUSTRIA AUTOMOTIVE GMBH
Deutschstraße 10
A-1230 Wien
www.tuv.at



PBV-TAA-005 Rev. 00

Fahrzeug-Nr. / Vehicle-No.	#14
FIN / VIN	VBKLSTP38KM735473
Variante / Version / Variant / Version	B / -
Nenn Drehzahl / rated engine speed [min ⁻¹]	5500
Leerlaufdrehzahl / idling engine speed [min ⁻¹]	1400
Kraftstoff / fuel	Gasoline (E5)
Fahrzeugmasse / vehicle mass [kg]	160
Schwungmasse / inertia mass [kg]	230
f ₀ / f ₂ [N / N/(km/h) ²]	20,2 / 0,0235

Umgebungsbedingungen / meteorological data	
Temperatur / Temperature	22,7 [°C]
Luftdruck / Air pressure	976 [hPa]
Luftfeuchtigkeit / Humidity	27,7 [%]

Messergebnisse / test data

Fahrzeug Nr. Vehicle No.	Abgasemissionen gemäß VO(EU) 134/2014*2016/1824 (WMTC Phase 2 / 3-2 – EURO 4) Exhaust emissions according to Regulation (EU) 134/2014*2016/1824 (WMTC Class 2 / 3-2 – EURO 4)								
	Type I Test					Type II Test			
	Abgaskomponente Exhaust component	Ergebnis Test [mg/km]	DF	Endergebnis Final result [mg/km]	Grenzwert ^{*)} Limit ^{*)} [mg/km]	Abgaskomponente Exhaust component	RPM	Endergebnis Final result [Vol%]	Grenzwert ^{*)} Limit ^{*)} [Vol%]
#14	CO	420	1,3	546	1140	CO Leerlauf normal CO idle	1400	0,0178	0,5
	HC	65	1,2	78	170	CO Leerlauf hoch CO high idle	2500	0,0118	0,3
	NO _x	25	1,2	30	90				

^{*)} Grenzwert lt. Richtlinie od. Verordnung der Fahrzeugtypgenehmigung

^{*)} limit value of directive which was valid when vehicle type approval was issued

Aktenzeichen / File number
20-TAHO-0142/E1/SFLO

Anhang / Annex 3: Prüfergebnisse Abgasemissionen / Test results exhaust emissions

Hersteller : Remus Innovation GmbH

Manufacturer

Type : HX12

Type

Prüfgegenstand : Austauschschalldämpfer

Subject replacement exhaust

TÜV AUSTRIA AUTOMOTIVE GMBH
Deutschstraße 10
A-1230 Wien
www.tuv.at



PBV-TAA-005 Rev. 00

Fahrzeug-Nr. / Vehicle-No.	#7
FIN / VIN	VBKLETP30MM777579
Variante / Version / Variant / Version	A / -
Nenn Drehzahl / rated engine speed [min ⁻¹]	8000
Leerlaufdrehzahl / idling engine speed [min ⁻¹]	1400
Kraftstoff / fuel	Gasoline (E5)
Fahrzeugmasse / vehicle mass [kg]	160
Schwungmasse / inertia mass [kg]	230
f ₀ / f ₂ [N / N/(km/h) ²]	20,2 / 0,0235

Umgebungsbedingungen / meteorological data	
Temperatur / Temperature	22,4 [°C]
Luftdruck / Air pressure	967 [hPa]
Luftfeuchtigkeit / Humidity	27,5 [%]

Messergebnisse / test data

Fahrzeug Nr. Vehicle No.	Abgasemissionen gemäß VO(EU) 134/2014*2016/1824 (WMTC Phase 2 / 3-2 – EURO 5) Exhaust emissions according to Regulation (EU) 134/2014*2016/1824 (WMTC Class 2 / 3-2 – EURO 5)								
	Type I Test					Type II Test			
	Abgaskomponente Exhaust component	Ergebnis Test [mg/km]	DF -	Endergebnis Final result [mg/km]	Grenzwert ¹⁾ Limit ¹⁾ [mg/km]	Abgaskomponente Exhaust component -	RPM [min ⁻¹]	Endergebnis Final result [Vol%]	Grenzwert ¹⁾ Limit ¹⁾ [Vol%]
#7	CO	608	1,3	790	1140	CO Leerlauf normal CO idle	1400	0,0152	0,5
	HC	70	1,3	91	170	CO Leerlauf hoch CO high idle	2500	0,0114	0,3
	NMHC	50	1,3	65	68				
	NO _x	21	1,3	27	90				

¹⁾ Grenzwert lt. Richtlinie od. Verordnung der Fahrzeugtypgenehmigung

^{*)} limit value of directive which was valid when vehicle type approval was issued

Aktenzeichen / File number
20-TAHO-0142/E1/SFLO

Anhang / Annex 3: Prüfergebnisse Abgasemissionen / Test results exhaust emissions

Hersteller : Remus Innovation GmbH

Manufacturer

Type : HX12

Type

Prüfgegenstand : Austauschschalldämpfer

Subject replacement exhaust

TÜV AUSTRIA AUTOMOTIVE GMBH
Deutschstraße 10
A-1230 Wien
www.tuv.at



PBV-TAA-005 Rev. 00

Fahrzeug-Nr. / Vehicle-No.	#1
FIN / VIN	VBKUSVP35MM781894
Variante / Version / Variant / Version	A / -
Nenn Drehzahl / rated engine speed [min ⁻¹]	8000
Leerlaufdrehzahl / idling engine speed [min ⁻¹]	1400
Kraftstoff / fuel	Gasoline (E5)
Fahrzeugmasse / vehicle mass [kg]	160
Schwungmasse / inertia mass [kg]	230
f ₀ / f ₂ [N / N/(km/h) ²]	20,2 / 0,0235

Umgebungsbedingungen / meteorological data	
Temperatur / Temperature	22,7 [°C]
Luftdruck / Air pressure	983,7 [hPa]
Luftfeuchtigkeit / Humidity	27,7 [%]

Messergebnisse / test data

Fahrzeug Nr. Vehicle No.	Abgasemissionen gemäß VO(EU) 134/2014*2016/1824 (WMTC Phase 3 / 3-2 – EURO 5) Exhaust emissions according to Regulation (EU) 134/2014*2016/1824 (WMTC Class 3 / 3-2 – EURO 5)								
	Type I Test					Type II Test			
	Abgaskomponente Exhaust component	Ergebnis Test [mg/km]	DF -	Endergebnis Final result [mg/km]	Grenzwert ¹⁾ Limit ¹⁾ [mg/km]	Abgaskomponente Exhaust component -	RPM [min ⁻¹]	Endergebnis Final result [Vol%]	Grenzwert ¹⁾ Limit ¹⁾ [Vol%]
#1	CO	439	1,3	571	1000	CO Leerlauf normal CO idle	1400	0,00	0,5
	HC	47	1,3	61	100	CO Leerlauf hoch CO high idle	2500	0,01	0,3
	NMHC	38	1,3	50	68				
	NO _x	39	1,3	51	60				



Beschreibungsmappe Nr. HX12/01 für die EU-Typgenehmigung eines Auspuffs (abgasmindernde Einrichtung und lärmindernde Einrichtung) als STE gemäß Artikel 27 der Verordnung (EU) Nr. 168/2013	Datum / date 03.08.2020 geändert / <i>modified</i> 21.04.2022
Information folder No. HX12/01 relating to EU type-approval of an exhaust (pollution – control device and noise-abatement device) as a STU according to article 27 of the Regulation (EU) no. 168/2013	Blatt 1 von 1 / Sheet 1 of 1

Inhaltsverzeichnis / table of contents:

	Zeichnungs-Nr. <i>Drawing – no.</i>	Datum <i>date</i>
Beschreibungsbogen / Information document HX12/01		01.03.2022
Zeichnung Schalldämpfer / <i>Drawing of silencer</i>	20ESD07161.1	16.07.2020
Stückliste / <i>Parts list</i>	20ESD07161.2	16.07.2020
Zeichnung VBR / <i>Drawing connecting pipe</i>	20ESD07161.3	16.07.2020
Stückliste VBR / Parts list connecting pipe	20ESD07162.4	21.04.2022
Zeichnung VBR / <i>Drawing connecting pipe</i>	20ESD07161.5	16.07.2020
Stückliste VBR / Parts list connecting pipe	20ESD07162.6	21.04.2022
Zeichnung Gesamtanlage / Drawing noise reduction system	20ESD07162.7	21.04.2022
Zeichnung Gesamtanlage / Drawing noise reduction system	20ESD07162.8	21.04.2022
Montageanleitung / <i>Mounting instruction</i>	Husqvarna 701 Supermoto / Enduro KTM 690 SMC-R / Enduro R	

Ort / place: Bärnbach

Datum / date: 21.04.2022

Unterschrift / signature

Name und Stellung im Unternehmen /

Name and position in the company:

Stephan Zöchling, CEO

Beschreibungsbogen Nr. HX12/01 für die EU-Typgenehmigung eines Abgassystems (abgasmindernde Einrichtung und lärmindernden Einrichtung) als STE gemäß Artikel 27 der Verordnung (EU) Nr. 168/2013	Datum / date 30.07.2020 geändert / modified 11.04.2022
Information document No. HX12/01 relating to EU type-approval of an exhaust (pollution – control device and noise-abatement device) as a STU according to article 27 of the Regulation (EU) no. 168/2013	Blatt 1 von 8 / Sheet 1 of 8

B Allgemeine Angaben zu Systemen, Bauteilen und selbständigen technischen Einheiten
General information concerning systems, components or separate technical units

- 0.7 Fabrikmarke(n) (Firmenname(n) des Herstellers) : REMUS
Make(s) (trade name(s) of manufacturer)
- 0.8 Typ : HX12
Type
- 0.8.1 Handelsname(n) (sofern vorhanden) : N/A
Commercial name(s) (if available)
- 0.8.2 Typgenehmigungsnummer(n), sofern vorhanden : e24*134/2014*2018/295H*00306*00
Type-approval number(s) (if available)
- 0.8.3 Typgenehmigung(en) erteilt am (Datum, falls bekannt) : 13.10.2020
Type-approval(s) issued on (date, if available)
- 0.9 Firmenname und Anschrift des Herstellers : Remus Innovation GmbH
Company name and address of manufacturer
Ruhmannstraße 11
A-8570 Voitsberg
- 0.9.1 Name(n) und Anschrift(en) der Fertigungsstätte(n) : Remus Innovation Forschungs- und
Name(s) and address(es) of assembly plants
Abgasanlagen Produktions GmbH
Dr. Niederdorferstraße 25
A-8572 Bärnbach

Remus Innovation GmbH
Ruhmannstraße 11
A-8570 Voitsberg
- 0.9.2 Gegebenenfalls Name und Anschrift des Bevollmächtigten des : N/A
Herstellers
Name and address of manufacturer's authorised representative, if any
- 0.10 **Fahrzeug(e), für welche(s) das System/die selbständige technische Einheit bestimmt ist**
Vehicle(s) for which the system/separate technical unit is intended for
- 0.10.1 Typ : Siehe Tabelle 1 / see table 1
Type
- 0.10.2 Variante : Siehe Tabelle 1 / see table 1
Variant
- 0.10.3 Version : Siehe Tabelle 1 / see table 1
Version
- 0.10.4 Handelsname(n) (sofern vorhanden) : Siehe Tabelle 1 / see table 1
Commercial name(s) (if available)
- 0.10.5 Klasse, Unterklasse und Unter-Unterklasse des Fahrzeugs : Siehe Tabelle 1 / see table 1
Category, subcategory and sub-subcategory of vehicle

C Allgemeine Angaben zur Übereinstimmung der Produktion und zum Zugang zu Reparatur- und
Wartungsinformationen
General information regarding conformity of production and access to repair and maintenance information

1. ALLGEMEINE BAUMERKMALE
GENERAL CONSTRUCTION CHARACTERISTICS

- 1.8 Leistung der Antriebseinheit
Propulsion unit performance
- 1.8.1 Angegebene Höchstgeschwindigkeit des Fahrzeugs : Siehe Tabelle 2 / see table 2
Declared maximum vehicle speed
- 1.8.2 Bauartbedingte Höchstgeschwindigkeit des Fahrzeugs und Gang, : siehe Fahrzeugtypengenehmigung
in dem diese erreicht wird

Beschreibungsbogen Nr. HX12/01 für die EU-Typgenehmigung eines Abgassystems (abgasmindernde Einrichtung und lärmindernden Einrichtung) als STE gemäß Artikel 27 der Verordnung (EU) Nr. 168/2013	Datum / date 30.07.2020 geändert / modified 11.04.2022
Information document No. HX12/01 relating to EU type-approval of an exhaust (pollution – control device and noise-abatement device) as a STU according to article 27 of the Regulation (EU) no. 168/2013	Blatt 2 von 8 / Sheet 2 of 8

	<i>Maximum design vehicle speed and gear in which it is reached</i>	see WVTA
1.8.3	Maximale Nutzleistung des Verbrennungsmotors bei Luft/Kraftstoff-Verhältnis <i>Maximum net power combustion engine at AF-ratio</i>	: Siehe Tabelle 2 L/K-Verhältnis see table 2 A/F-ratio
1.8.4	Maximales Nutzdrehmoment des Verbrennungsmotors at AF-ratio bei Luft/Kraftstoff-Verhältnis <i>Maximum net torque combustion engine</i>	: Siehe Tabelle 2 L/K-Verhältnis see table 2 A/F-ratio
1.8.5	Maximale Nenndauerleistung des Elektromotors (Leistung über 15/ 30 Minuten) <i>Maximum continuous-rated power electric motor (15/30 minutes power)</i>	: N/A
1.8.6	Maximales Nenn-Dauerdrehmoment des Elektromotors <i>Maximum continuous-rated torque electric motor</i>	: N/A
1.8.7	Maximale Dauer-Gesamtleistung des Antriebs (der Antriebe) <i>Maximum continuous total power for propulsion(s)</i>	: N/A
1.8.8	Maximales Dauer-Gesamtdrehmoment des Antriebs (der Antriebe) <i>Maximum continuous total torque for propulsion(s)</i>	: N/A
1.8.9	Maximale Spitzenleistung des Antriebs (der Antriebe) <i>Maximum peak power for propulsion(s)</i>	: N/A
4.0	Allgemeine Angaben zu Umweltverträglichkeit und Antriebsleistung	
	General information on environmental and propulsion performance	
4.0.1	Umweltanforderungsstufe <i>Environmental step</i>	: Siehe Tabelle 2 / see table 2
4.0.2	Kraftstoffverbrauch (nähere Angaben für jeden geprüften Kraftstoff) <i>Fuel consumption (provide details for each reference fuel tested)</i>	: Siehe Tabelle 2 / see table 2
4.0.3	CO2 Emissionen <i>CO 2 emissions</i>	[g/km] : Siehe Tabelle 2 / see table 2
4.0.4	Energieverbrauch <i>Energy consumption</i>	[Wh/km] : N/A
4.0.5	Elektrische Reichweite <i>Electric range</i>	[km] : N/A
4.0.6	Geräuschpegel <i>Sound level</i>	
4.0.6.1	Grenzwert für L _{Urban} <i>Limit value for L_{Urban}</i>	[dB(A)] : 77
4.1	System zur Minderung der Auspuffemissionen	
	Tailpipe emission-control system	
4.1.1	Kurze Beschreibung und Schemazeichnung des Systems zur Minderung der Auspuffemissionen und seiner Steuerung <i>Brief description and schematic drawing of the tailpipe emission-control system and its control</i>	: Lambdasonde (Kontrolleinrichtung) ist im Serienzustand. Weitere Details siehe Zeichnungen im Beschreibungsbogen <i>Lambda Sensor (control device) remain unchanged (serial condition). More details please refer to drawings in information document</i>
4.1.2	Katalysator <i>Catalytic converter</i>	

Beschreibungsbogen Nr. HX12/01 für die EU-Typgenehmigung eines Abgassystems (abgasmindernde Einrichtung und lärmindernden Einrichtung) als STE gemäß Artikel 27 der Verordnung (EU) Nr. 168/2013	Datum / date 30.07.2020 geändert / modified 11.04.2022
Information document No. HX12/01 relating to EU type-approval of an exhaust (pollution – control device and noise-abatement device) as a STU according to article 27 of the Regulation (EU) no. 168/2013	Blatt 3 von 8 / Sheet 3 of 8

- | | | | |
|------------|---|---|--|
| 4.1.2.1 | Konfiguration, Anzahl der Katalysatoren und Monolithen (nachstehende Angaben sind für jede Einheit einzeln anzugeben)
<i>Configuration, number of catalytic converters and elements (information to be provided for each separate unit)</i> | : | Details siehe Zeichnungen im Beschreibungsbogen
<i>Details please refer to drawings in information document</i> |
| 4.1.2.2 | Zeichnung mit Abmessungen, Form und Volumen des (der) Katalysators (Katalysatoren)
<i>Drawing with dimensions, shape and volume of the catalytic converter(s)</i> | : | Details siehe Zeichnungen im Beschreibungsbogen
<i>Details please refer to drawings in information document</i> |
| 4.1.2.3 | Katalytische Reaktion
<i>Catalytic reaction</i> | : | 3-Weg-Katalysator
<i>3-way catalytic converter</i> |
| 4.1.2.4 | Gesamtbeschichtung mit Edelmetall

<i>Total charge of precious metals</i> | : | Details siehe Zeichnungen im Beschreibungsbogen
<i>Details please refer to drawings in information document</i> |
| 4.1.2.5 | Verhältnis der verwendeten Edelmetalle zueinander

<i>Relative concentration</i> | : | Details siehe Zeichnungen im Beschreibungsbogen
<i>Details please refer to drawings in information document</i> |
| 4.1.2.6 | Trägerkörper (Aufbau und Werkstoff)

<i>Substrate (structure and material)</i> | : | Details siehe Zeichnungen im Beschreibungsbogen
<i>Details please refer to drawings in information document</i> |
| 4.1.2.7 | Zellendichte

<i>Cell density</i> | : | Details siehe Zeichnungen im Beschreibungsbogen
<i>Details please refer to drawings in information document</i> |
| 4.1.2.8 | Katalysatorgehäuse

<i>Casing for the catalytic converter(s)</i> | : | Details siehe Zeichnungen im Beschreibungsbogen
<i>Details please refer to drawings in information document</i> |
| 4.1.2.9 | Lage des Katalysators (der Katalysatoren) (Ort und Bezugsentfernung innerhalb des Auspuffstrangs)
<i>Location of the catalytic converter(s) (place and reference distance in the exhaust line)</i> | : | Details siehe Zeichnungen im Beschreibungsbogen
<i>Details please refer to drawings in information document</i> |
| 4.1.2.10 | Katalysator-Wärmeschutzschild
<i>Catalyst heat-shield</i> | : | ja / nein
yes / no |
| 4.1.2.11 | Kurze Beschreibung und Schemazeichnung des Regenerationssystems/Verfahren der Abgasnachbehandlungssysteme und Steuerungssystem
<i>Brief description and schematic drawing of the regeneration system/ method of exhaust after-treatment systems and its control system</i> | : | N/A |
| 4.1.2.11.1 | Normaler Betriebstemperaturbereich
<i>Normal operating temperature range</i> | : | N/A |
| 4.1.2.11.2 | Selbstverbrauchende Reagenzien
<i>Consumable reagents</i> | : | ja / nein
yes / no |
| 4.1.2.11.3 | Kurze Beschreibung und Schemazeichnung des Nasssystems für den Reagensfluss und seines Steuerungssystems
<i>Brief description and schematic drawing of the reagent flow (wet) system and its control system</i> | : | N/A |
| 4.1.2.11.4 | Art und Konzentration des für die katalytische Reaktion erforderlichen Reagens
<i>Type and concentration of reagent needed for catalytic action</i> | : | N/A |

Beschreibungsbogen Nr. HX12/01 für die EU-Typgenehmigung eines Abgassystems (abgasmindernde Einrichtung und lärmindernden Einrichtung) als STE gemäß Artikel 27 der Verordnung (EU) Nr. 168/2013	Datum / date 30.07.2020 geändert / modified 11.04.2022
Information document No. HX12/01 relating to EU type-approval of an exhaust (pollution – control device and noise-abatement device) as a STU according to article 27 of the Regulation (EU) no. 168/2013	Blatt 4 von 8 / Sheet 4 of 8

4.1.2.11.5	Normaler Betriebstemperaturbereich des Reagens <i>Normal operational temperature range of reagent</i>	[K] : N/A
4.1.2.11.6	Ergänzung des Reagensvorrats erforderlich im laufenden Betrieb/bei der planmäßigen Wartung <i>Frequency of reagent refill</i>	: N/A
4.1.2.12	Teilenummer <i>Identifying part number</i>	: Details siehe Zeichnungen im Beschreibungsbogen <i>Details please refer to drawings in information document</i>
4.1.3	Sauerstoffsonde(n) <i>Oxygen sensor(s)</i>	
4.1.3.1	Zeichnung(en) des Bauteils (der Bauteile) der Sauerstoffsonde <i>Oxygen sensor component(s) drawing(s)</i>	: Serienteile / siehe Fahrzeugtypen-genehmigung <i>Original parts / see WVTA</i>
4.1.3.2	Zeichnung der Auspuffanlage mit Lage(n) der Sauerstoffsonde (Abmessungen bezogen auf die Auslassventile) <i>Drawing of exhaust device with oxygen sensor location(s) (dimensions relative to exhaust valves)</i>	: Details siehe Zeichnungen im Beschreibungsbogen <i>Details please refer to drawings in information document</i>
4.1.3.3	Regelbereich <i>Control range(s)</i>	: siehe 4.1.3.1 <i>see 4.1.3.1</i>
4.1.3.4	Teilenummer(n) <i>Identifying part number(s)</i>	: siehe 4.1.3.1 <i>see 4.1.3.1</i>
4.1.3.5	Beschreibung der Heizanlage und der Heizstrategie für die Sauerstoffsonde <i>Description of oxygen sensor heating system and heating strategy</i>	: N/A
4.1.3.6	Wärmeschutzschild(e) für die Sauerstoffsonde <i>Oxygen sensor heat shield(s)</i>	: ja / nein <i>yes / no</i>
4.1.4	Sekundärlufteinblasung (Lufteinblasung in den Auspuff) <i>Secondary air-injection (air-inject in exhaust)</i>	
4.1.4.1	Kurze Beschreibung und Schemazeichnung des Systems für die Sekundärlufteinblasung und seines Steuerungssystems <i>Brief description and schematic drawing of the secondary air-injection system and its control system</i>	: N/A
4.1.4.2	Konfiguration (mechanisch, Selbstansaugung, Luftpumpe usw.) <i>Configuration (mechanical, pulse air, air pump etc.)</i>	: N/A
4.1.4.3	Arbeitsweise <i>Working principle</i>	: N/A
4.1.5	Abgasrückführung (AGR) <i>External exhaust gas recirculation (EGR)</i>	
4.1.5.1	Kurze Beschreibung und Schemazeichnung des AGR-Systems (Abgasstrom) und seines Steuerungssystems <i>Brief description and schematic drawing of the EGR system (exhaust flow) and its control system</i>	: N/A
4.1.5.2	Merkmale <i>Characteristics</i>	: N/A
4.1.5.3	Wassergekühltes AGR-System <i>Water-cooled EGR system</i>	: N/A
4.1.5.4	Luftgekühltes AGR-System <i>Air-cooled EGR system</i>	: N/A

Beschreibungsbogen Nr. HX12/01 für die EU-Typgenehmigung eines Abgassystems (abgasmindernde Einrichtung und lärmindernden Einrichtung) als STE gemäß Artikel 27 der Verordnung (EU) Nr. 168/2013	Datum / date 30.07.2020 geändert / modified 11.04.2022
Information document No. HX12/01 relating to EU type-approval of an exhaust (pollution – control device and noise-abatement device) as a STU according to article 27 of the Regulation (EU) no. 168/2013	Blatt 5 von 8 / Sheet 5 of 8

- 4.1.6 Partikelfilter
Particulate filter
- 4.1.6.1 Zeichnung der Bauteile des Partikelfilters mit Abmessungen, Form und Volumen des Partikelfilters
PT component drawing with dimensions, shape and capacity of the particulate filter : N/A
- 4.1.6.2 Aufbau des Partikelfilters
Design of the particulate filter : N/A
- 4.1.6.3 Kurze Beschreibung und Schemazeichnung des Partikelfilters und seines Steuersystems
Brief description and schematic drawing of the particulate filter and its control system : N/A
- 4.1.6.4 Lage (Referenzentfernung innerhalb des Auspuffstrangs)
Location (reference distance in the exhaust line) : N/A
- 4.1.6.5 Verfahren oder Einrichtung zur Regenerierung, Beschreibung und Zeichnung
Method or system of regeneration, description and drawing : N/A
- 4.1.6.6 Teilenummer
Identifying part number : N/A
- 4.1.7 Mager-NO_x-Falle
Lean NO_x trap
- 4.1.7.1 Funktionsprinzip der Mager-NO_x-Falle
Operation principle of lean NO_x trap : N/A
- 4.1.8 Zusätzliche emissionsmindernde Einrichtungen (falls vorhanden und nicht an anderer Stelle erwähnt)
Additional tailpipe emission-control devices (if any not covered under another heading)
- 4.1.8.1 Arbeitsweise
Working principle : N/A
- 4.4 Zusätzliche Angaben zu Umweltverträglichkeit und Antriebsleistung**
Additional information on environmental and propulsion unit performance
- 4.4.4 Dieser Beschreibungsbogen ist in Bezug auf die lärmindernden Einrichtungen durch den geltenden Beschreibungsbogen gemäß der UNECE-Regelung Nr. 92 zu ergänzen.
Applicable information document set out in respectively UN Regulation No 92 shall supplement this information document with regards to the noise-abatement devices installed on the vehicle.
- Krafttrad
Motorcycle
- Marke (Handelsname des Herstellers)
Make (Trade name of manufacturer) : Siehe Tabelle 1 / *see table 1*
- EU-Typengenehmigungsnummer : Siehe Tabelle 3 / *see table 3*
- Ab Baujahr
From model year : Siehe Tabelle 3 / *see table 3*
- Verbrennungsmotor
Combustion engine
- Baumusterbezeichnung gemäß Kennzeichnung am Motor oder sonstige Identifizierungsmerkmale
Engine code (as marked on the engine or other means of identification) : Siehe Tabelle 3 / *see table 3*
- Maximale Nennleistung [kW/min⁻¹] : Siehe Tabelle 2 / *see table 2*

Beschreibungsbogen Nr. HX12/01 für die EU-Typgenehmigung eines Abgassystems (abgasmindernde Einrichtung und lärmindernden Einrichtung) als STE gemäß Artikel 27 der Verordnung (EU) Nr. 168/2013	Datum / date 30.07.2020 geändert / modified 11.04.2022
Information document No. HX12/01 relating to EU type-approval of an exhaust (pollution – control device and noise-abatement device) as a STU according to article 27 of the Regulation (EU) no. 168/2013	Blatt 6 von 8 / Sheet 6 of 8

rated maximum net power

Arbeitsweise Working principle	:	Fremdzündung / Selbstzündung positive ignition / compressed ignition
Arbeitsweise cycle	:	Viertakt four stroke
Hubvolumen Enginge capacity	[cm ³]:	Siehe Tabelle 3 / see table 3
Kraftübertragung Drive-train	:	Kette chain
Getriebe Transmission	:	Manuell manual
Anzahl der Gänge Number of gears	:	6
Übersetzungsverhältnisse Gear ratios	I :	Siehe Tabelle 4 / see table 4
	II :	Siehe Tabelle 4 / see table 4
	III :	Siehe Tabelle 4 / see table 4
	IV :	Siehe Tabelle 4 / see table 4
	V :	Siehe Tabelle 4 / see table 4
	VI :	Siehe Tabelle 4 / see table 4
	VII :	-
Antriebsübersetzung Final drive	:	Siehe Tabelle 4 / see table 4

Tabelle 1 :
table 1 :

Fzg. Nr. Vehicle	Marke	Typ Type	Variante Variant	Version Version	Handelsname(n) Commercial name(s)	Klasse Category
1	Husqvarna	Husqvarna 701	A	-	Husqvarna 701 Supermoto	L3e, A3
2	Husqvarna	Husqvarna 701	A	-	Husqvarna 701 Supermoto	L3e, A2
3	Husqvarna	Husqvarna 701	B	-	Husqvarna 701 Enduro	L3e, A3
4	Husqvarna	Husqvarna 701	B	-	Husqvarna 701 Enduro	L3e, A2
5	Husqvarna	Husqvarna 701	C	-	Husqvarna 701 Enduro LR	L3e, A3
6	Husqvarna	Husqvarna 701	C	-	Husqvarna 701 Enduro LR	L3e, A2
7	KTM	KTM 690 LC4	A	-	KTM 690 Enduro R	L3e, A3
8	KTM	KTM 690 LC4	A	-	KTM 690 Enduro R	L3e, A2
9	KTM	KTM 690 LC4	B	-	KTM 690 SMC R	L3e, A3
10	KTM	KTM 690 LC4	B	-	KTM 690 SMC R	L3e, A2
11	KTM	KTM 690 LC4	B	-	KTM 690 Enduro R	L3e, A3
12	KTM	KTM 690 LC4	A	-	KTM 690 Enduro R	L3e, A2
13	KTM	KTM 690 LC4	B	-	KTM 690 SMC R	L3e, A3
14	KTM	KTM 690 LC4	A	-	KTM 690 SMC R	L3e, A2
15	GASGAS	GG LC4	A	-	GasGas ES 700	L3e, A3
16	GASGAS	GG LC4	B	-	GasGas SM 700	L3e, A3
17	GASGAS	GG LC4	A	-	GasGas ES 700	L3e, A2
18	GASGAS	GG LC4	B	-	GasGas SM 700	L3e, A2

Beschreibungsbogen Nr. HX12/01 für die EU-Typgenehmigung eines Abgassystems (abgasmindernde Einrichtung und lärmindernden Einrichtung) als STE gemäß Artikel 27 der Verordnung (EU) Nr. 168/2013	Datum / date 30.07.2020 geändert / modified 11.04.2022
Information document No. HX12/01 relating to EU type-approval of an exhaust (pollution – control device and noise-abatement device) as a STU according to article 27 of the Regulation (EU) no. 168/2013	Blatt 7 von 8 / Sheet 7 of 8

Tabelle 2 :
table 2 :

Fzg. Nr. Vehicle	Höchstgeschwindigkeit Maximum vehicle speed [km/h]	Maximale Nutzleistung Maximum net power [kW / min-1]	Maximales Nutzdrehmoment Maximum net torque [Nm / min-1]	Umwelt- anforderungsstufe Environmental step
1	200	55 / 8000	71 / 6750	Euro 5
2	160	31 / 7000	54 / 5000	Euro 5
3	180	55 / 8000	71 / 6750	Euro 5
4	160	31 / 7000	54 / 5000	Euro 5
5	180	55 / 8000	71 / 6750	Euro 5
6	160	31 / 7000	54 / 5000	Euro 5
7	180	55 / 8000	70 / 7000	Euro 5
8	160	31 / 7000	54 / 5000	Euro 5
9	200	55 / 8000	70 / 7000	Euro 5
10	160	31 / 7000	54 / 5000	Euro 5
11	190	55 / 8000	70 / 7000	Euro 4
12	145	32 / 5500	56 / 5000	Euro 4
13	200	55 / 8000	70 / 7000	Euro 4
14	150	32 / 5500	56 / 5000	Euro 4
15	180	55 / 8000	71 / 6750	Euro 5
16	200	55 / 8000	71 / 6750	Euro 5
17	160	31 / 7000	54 / 5000	Euro 5
18	160	31 / 7000	54 / 5000	Euro 5

Tabelle 3 :
table 3 :

Fzg. Nr. Vehicle	Motorhersteller Engine manufacturer	Typengenehmigungsnummer type approval number	Baumusterbezeichnung Motor Engine code	Hubvolumen Engine capacity [cm³]	Baujahr model year
1	KTM	e1*168/2013*00032*..	768	693	2020
2	KTM	e1*168/2013*00034*..	768	693	2020
3	KTM	e1*168/2013*00032*..	768	693	2020
4	KTM	e1*168/2013*00034*..	768	693	2020
5	KTM	e1*168/2013*00032*..	768	693	2020
6	KTM	e1*168/2013*00034*..	768	693	2020
7	KTM	e1*168/2013*00147*..	768	693	2020
8	KTM	e1*168/2013*00146*..	768	693	2020
9	KTM	e1*168/2013*00147*..	768	693	2020

Beschreibungsbogen Nr. HX12/01 für die EU-Typgenehmigung eines Abgassystems (abgasmindernde Einrichtung und lärmindernden Einrichtung) als STE gemäß Artikel 27 der Verordnung (EU) Nr. 168/2013	Datum / date 30.07.2020 geändert / modified 11.04.2022
Information document No. HX12/01 relating to EU type-approval of an exhaust (pollution – control device and noise-abatement device) as a STU according to article 27 of the Regulation (EU) no. 168/2013	
	Blatt 8 von 8 / Sheet 8 of 8

10	KTM	e1*168/2013*00146*..	768	693	2020
11	KTM	e1*168/2013*00147*..	768	693	2019
12	KTM	e1*168/2013*00146*..	768	693	2019
13	KTM	e1*168/2013*00147*..	768	693	2019
14	KTM	e1*168/2013*00146*..	768	693	2019
15	KTM	e1*168/2013*00298*00	768	693	2022
16	KTM	e1*168/2013*00298*00	768	693	2022
17	KTM	e1*168/2013*00307*00	768	693	2022
18	KTM	e1*168/2013*00307*00	768	693	2022

Tabelle 4 :
table 4 :

Fzg. Nr. Vehicle	Übersetzungsverhältnisse Gear ratio						Antriebsübersetzung final drive
	I	II	III	IV	V	VI	
1	2,5	1,75	1,35	1,095	0,957	0,87	2,63
2	2,5	1,75	1,35	1,095	0,957	0,87	2,63
3	2,5	1,75	1,35	1,095	0,957	0,87	3,07
4	2,5	1,75	1,35	1,095	0,957	0,87	3,07
5	2,5	1,75	1,35	1,095	0,957	0,87	3,07
6	2,5	1,75	1,35	1,095	0,957	0,87	3,07
7	2,5	1,75	1,35	1,095	0,957	0,87	3,07
8	2,5	1,75	1,35	1,095	0,957	0,87	3,07
9	2,5	1,75	1,35	1,095	0,957	0,87	2,63
10	2,5	1,75	1,35	1,095	0,957	0,87	2,63
11	2,5	1,75	1,35	1,095	0,957	0,87	3,07
12	2,5	1,75	1,35	1,095	0,957	0,87	3,07
13	2,5	1,75	1,35	1,095	0,957	0,87	2,63
14	2,5	1,75	1,35	1,095	0,957	0,87	2,63
15	2,5	1,75	1,35	1,095	0,957	0,87	3,067
16	2,5	1,75	1,35	1,095	0,957	0,87	2,625
17	2,5	1,75	1,35	1,095	0,957	0,87	3,067
18	2,5	1,75	1,35	1,095	0,957	0,87	2,625

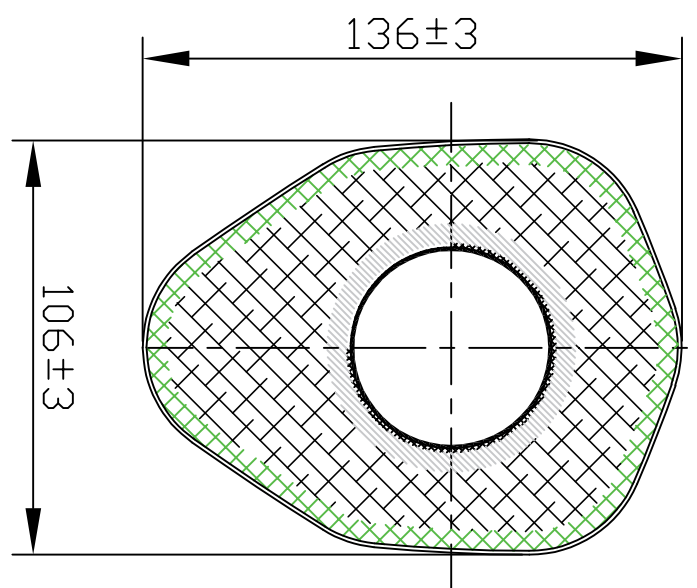

Schnitt B-B
Section B-B

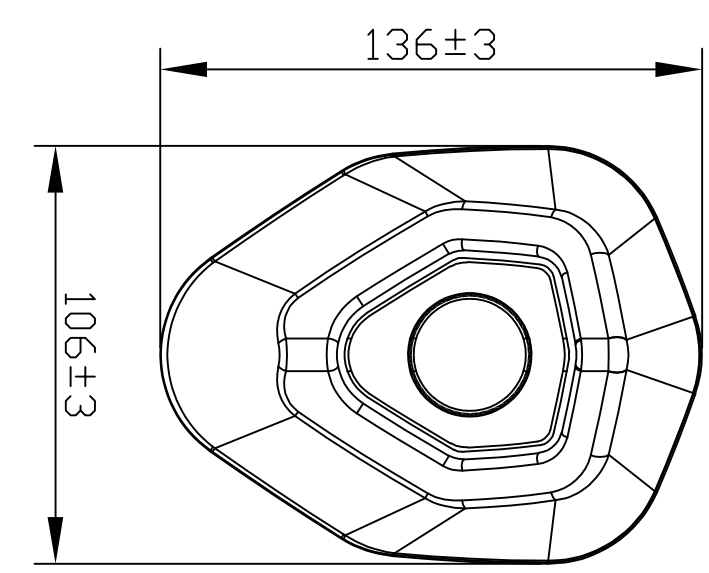

Ansicht A:
View A

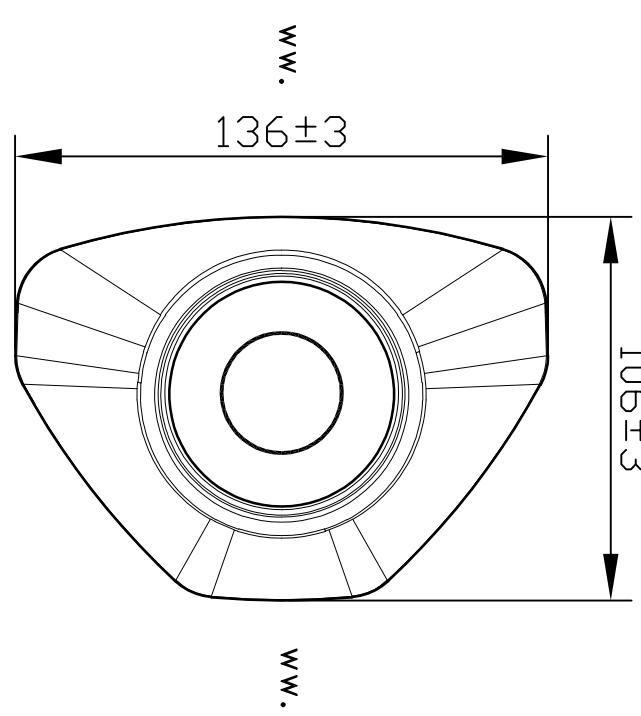

Innenrohr gelocht
inner pipe perforated
Ø30±0,2x1,2±0,3x140±5
10 Löcher/holes Ø8mm±0,5

konisches Innenrohr
conical inner pipe perforated
von Ø75x1±0,2 auf Ø50x345±15
Lochung/perforation Ø3±0,3
Abstand/distance 4,8±0,2

Ansicht A:
View A

Ansicht A:
View A

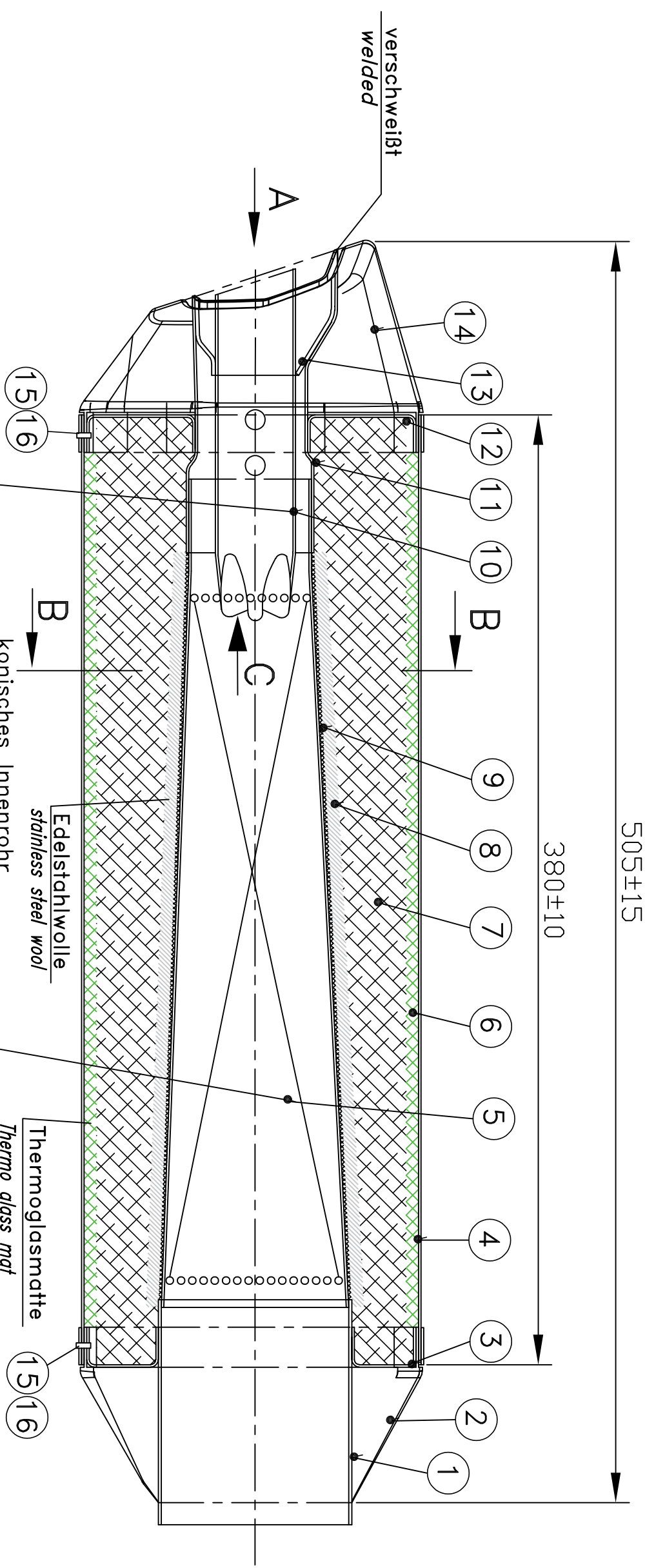

Ansicht C:
View C

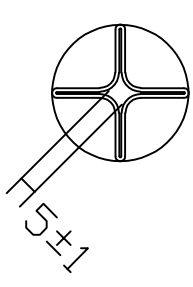

Datum	Name	Zeichnungnr	REMUS
Gez.:	16.07.20	TM	20ESD07161.1
Gepr.:	16.07.20	VL	Typ: HX12

Schalldämpfer/Silencer f. Motorrad



STÜCKLISTE / parts list

Pos. Nr.: Pos. Nr.:	Benennung description	Norm norm	Abmessungen dimensions	Werkstoff basis material	Stk. Einh. piece unity	Men.
1	Einlassrohr <i>Inlet pipe</i>	DIN2465	Ø76±0,5x1,2±0,3x 90±5	A opt.B opt.C	1	mm
2	Einlasskappe <i>Inlet cap</i>		106±3x136±3x1,2±0,3x56±3	A opt.B opt.D	1	Stk
3	Deckel <i>cover plate</i>	DIN 1541	103±3x133±3x1,2±0,3x12±3 ww.103±3x133±3x1,2±0,3x12±3 ww.103±3x133±3x1,2±0,3x12±3	A opt.B opt.C	1	mm
4	Schalldämpfermantel <i>silencer shell</i>	DIN1541	106±3x136±3x1,2±0,3x380±10 106±3x136±3x1,2±0,3x380±10 106±3x136±3x1,2±0,3x380±10	A opt.B opt.C	1	Stk
5	Konisches Innenrohr gelocht <i>conical inner pipe perforated</i>		von/from Ø75±1 auf Ø50x345±15 Lochung/perforation Ø3±0,3 Abstand/distance 4,8mm ±0,2	B opt. C	1	mm
6	Dämpfungsmaterial <i>damping material</i>			Thermoglasmatte <i>Thermo glass mat</i>	150 g	+20%-10%
7	Dämpfungsmaterial <i>damping material</i>			Glasfasermatte <i>glass fibre matt</i>	350 g	+20%-10%
8	Dämpfungsmaterial <i>damping material</i>			Edelstahlwolle <i>stainless steel wool</i>	120 g	+20%-10%
9	Drahtmaschengitter/ <i>wire mesh</i> Ø 0,16±0,04 ; w = 0,4±0,1		220±15x360±10	B	1	Stk
10	Innenrohr gelocht <i>inner pipe perforated</i>	DIN2465	Ø 30±0,2x1±0,3x140±5 10 Löcher/holes Ø8±0,5	B opt. C	1	mm
11	Innenrohr ungelocht <i>inner pipe unperforated</i>	DIN2465	Ø 48x1,2±0,3x160±5	B opt. C	1	mm
12	Deckel <i>cover plate</i>	DIN 1541	103±3x133±3x1,2±0,3x12±3 ww.103±3x133±3x1,2±0,3x12±3 ww.103±3x133±3x1,2±0,3x12±3	A opt.B opt.C	1	mm
13	Innenrohr ungelocht <i>inner pipe unperforated</i>	DIN1541	Ø48±2x1,2±0,3 x65±5	B opt. C	1	mm
14	Endkappe <i>End cap</i>		106±3x136±3x1,2±0,3x75±3	A opt. D	1	Stk
15	Nietband <i>rivet strap</i>		15x1x410±5	B opt. C	2	Stk
16	Niete/ <i>rivet</i>	XCAP EE	4,5x9	B	12 ±4	Stk

Werkstoff/material	Variante/variant
Carbon	A
Edelstahl / <i>stainless steel</i> 1.4301;1.4509;1.4512	B
Titan / <i>titan</i>	C
Kunststoff / <i>plastic</i> PA6.6-GF	D

Datum/date	Name	Zeichnungsnr/drawing-no	REMUS
Gez.: 16.07.20	V.L.	20ESD07161.2	Typ HX12
Gep.: 16.07.20	T.M.		
Geä.:	Gep.:		
Schalldämpfer/ <i>silencer</i> f. Motorrad			



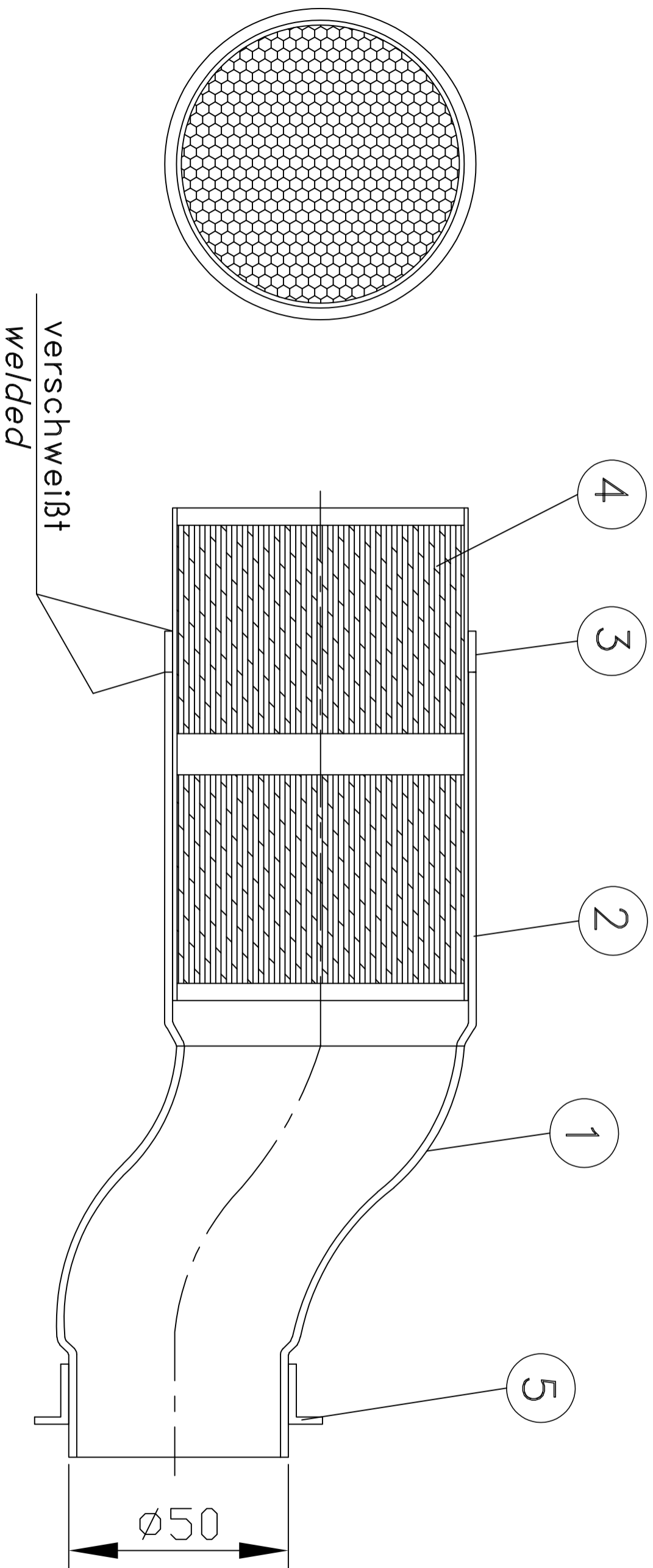

	Datum/ <i>date</i>	Name	Zeichnungnr/ <i>drawing-no.</i>	R E M U S
Gez.:	16.07.20	TM	20VBR07161.3	Typ: HX12
Gepr.:	16.07.20	VL		
Geän.:			Gepr.:	

Verbindungsrohr / *connecting pipe* f. KTM 690 SMC R, Enduro R

REMUS
PERFORMANCE SPORT EXHAUSTS

STÜCKLISTE / parts list

Pos. Nr.:	Benennung	Norm	Abmessungen	Werkstoff	Stk.	Einh.	Men.
Pos. Nr.:	<i>description</i>	<i>standard</i>	<i>dimensions</i>	<i>material</i>	<i>piece</i>	<i>unit</i>	
1	Katalysator <i>catalyst</i>		Ø70x120 s. drawing 20ESD07162.7	B	1	mm	
2	Einlassrohr <i>inlet pipe</i>	DIN2465	Ø65/ Ø50x1,2±0,3x290±20	B opt.C	1	mm	
3	Anschlagring <i>stop ring</i>		Ø76x1,2±0,3x10±1	B opt.C	1	mm	
4	Hülsenrohr <i>Sleeve tube</i>		Ø74,9±0,2x95±5	B opt.C	1	mm	
5	Dichtungsflansch <i>Sealing flange</i>		Ø70/ Ø50x1,2±0,3x30±2	B opt.C	1	mm	

Werkstoff/material	Variante/variant
Stahl aluminisiert / <i>steel aluminized</i>	A
Edelstahl / <i>stainless steel</i> 1.4301;1.4509;1.4512	B
Titan / <i>titan</i>	C
Aluminium	D

	Datum/date	Name	Zeichnungsnr/drawing-no	REMUS	
Gez.:	16.07.20	V.L.	20VBR07162.4	Typ HX12	
Gep.:	16.07.20	T.M.			
Geä.:	21.04.22	Gep.:			
Verbindungsrohr/ connecting pipe KTM690 SMC R,Enduro R					

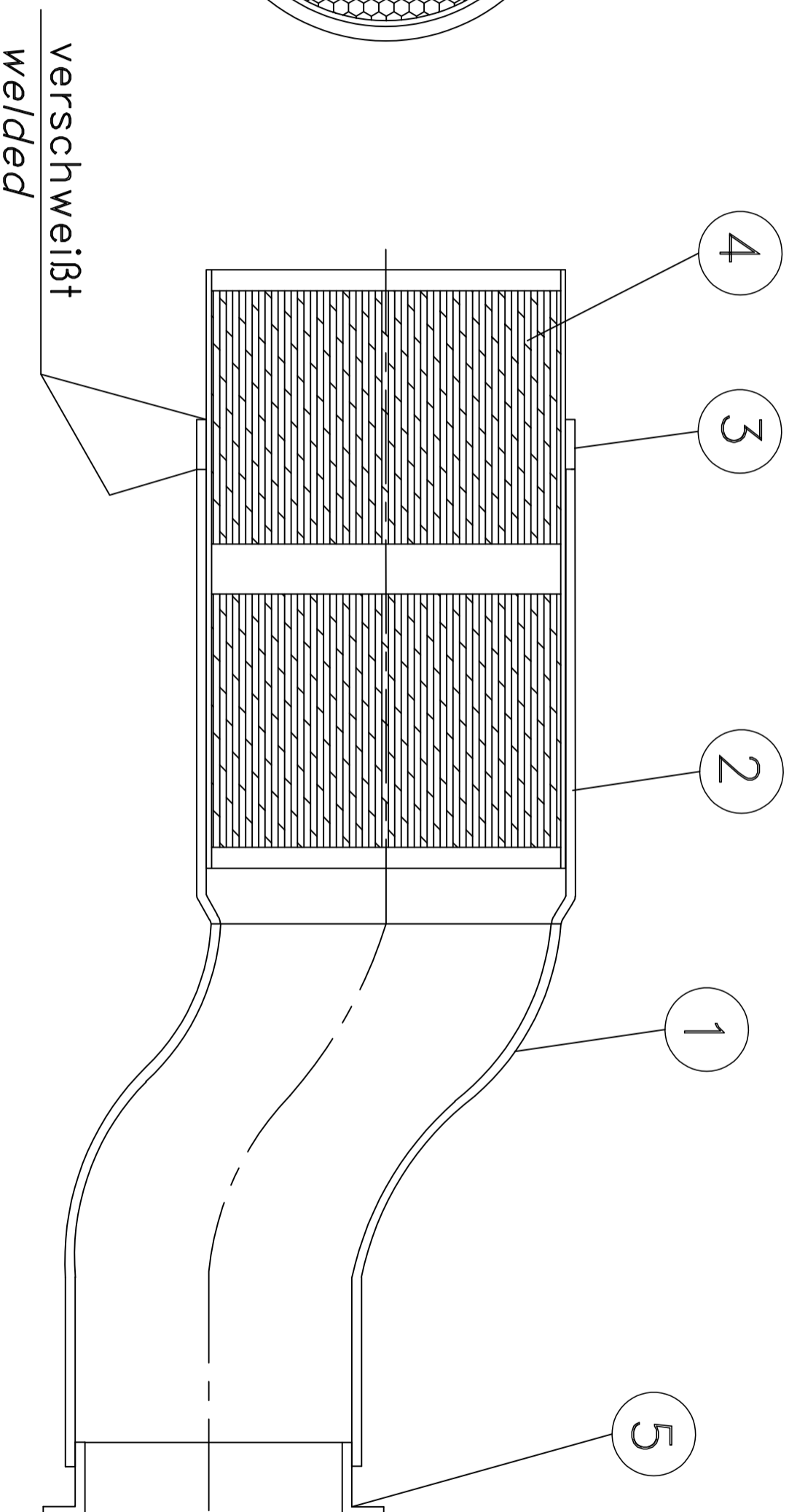
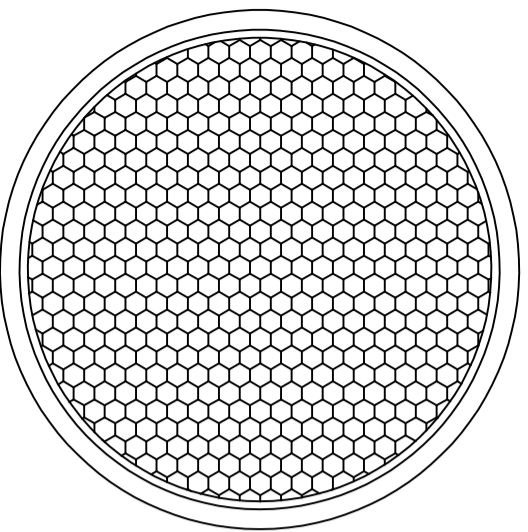

	Datum/ <i>date</i>	Name	Zeichnungnr/ <i>drawing-no.</i>	R E M U S
Gez.:	16.07.20	TM	20VBR07161.5	Typ: HX12
Gepr.:	16.07.20	VL		
Geñn.:			Gepr.:	

Verbindungsrohr / *connecting pipe* f. Husqvarna 701 Supermoto, Enduro,LR



STÜCKLISTE / parts list

Pos. Nr.:	Benennung	Norm	Abmessungen	Werkstoff	Stk.	Einh.	Men.
Pos. Nr.:	<i>description</i>	<i>standard</i>	<i>dimensions</i>	<i>material</i>	<i>piece</i>	<i>unit</i>	
1	Katalysator <i>catalyst</i>		Ø70x120 s. drawing 20ESD07162.8	B	1	mm	
2	Einlassrohr <i>inlet pipe</i>	DIN2465	Ø65x1,2±0,3x290±20	B opt.C	1	mm	
3	Anschlagring <i>stop ring</i>		Ø76x1,2±0,3x10±1	B opt.C	1	mm	
4	Hülsenrohr <i>Sleeve tube</i>		Ø74,9±0,2x95±5	B opt.C	1	mm	
5	Dichtungsflansch <i>Sealing flange</i>		Ø70/ Ø50x1,2±0,3x30±2	B opt.C	1	mm	

Werkstoff/material	Variante/variant
Stahl aluminert / <i>steel aluminized</i>	A
Edelstahl / <i>stainless steel</i> 1.4301;1.4509;1.4512	B
Titan / <i>titan</i>	C
Aluminium	D

	Datum/date	Name	Zeichnungsnr/drawing-no	REMUS	
Gez.:	16.07.20	V.L.	20VBR07162.6	Typ HX12	
Gep.:	16.07.20	T.M.			
Geä.:	21.04.22		Gep.:		
Verbindungsrohr/ connecting pipe Husqvarna 701 Supermoto/Enduro,LR					

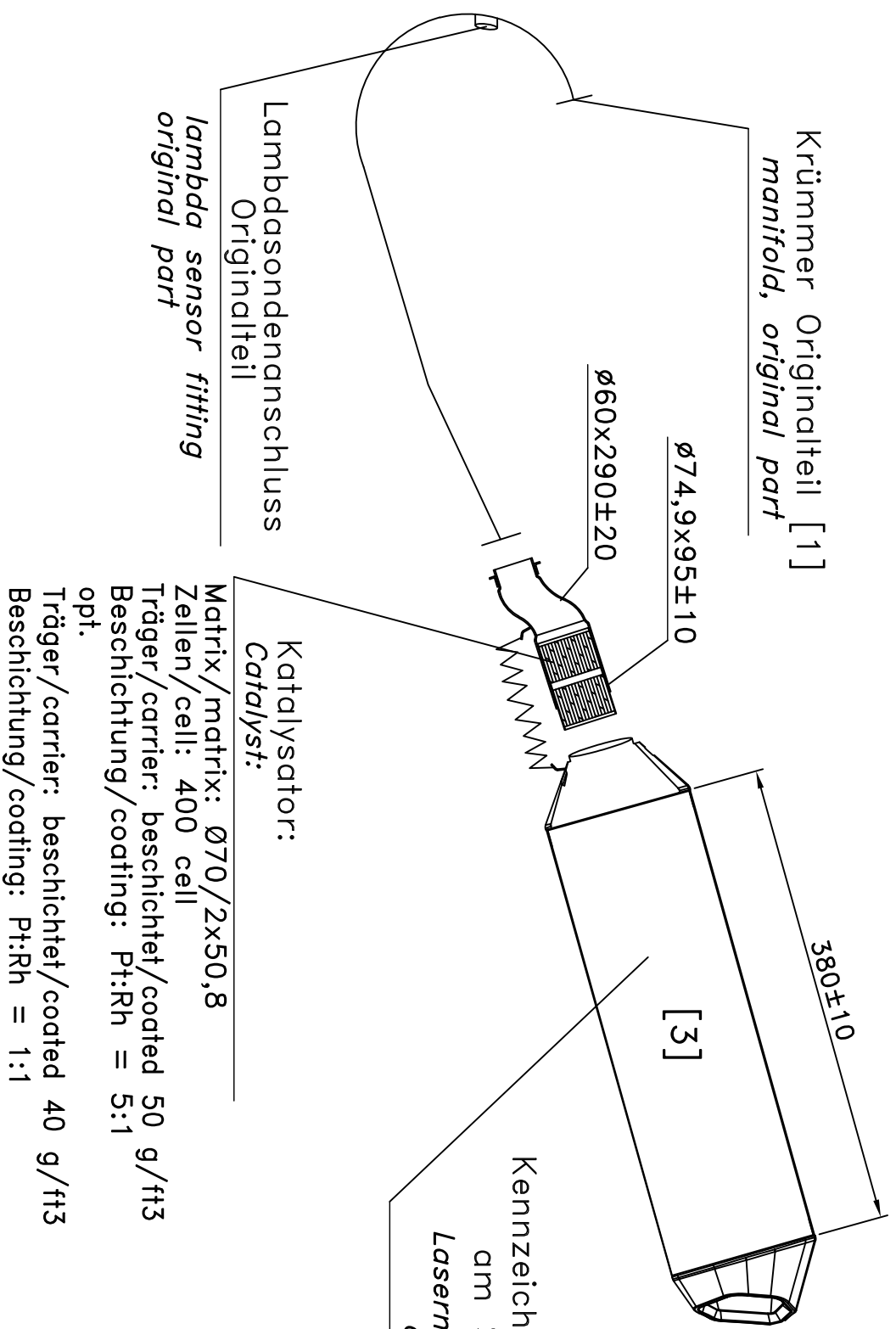

Katalysator:
Catalyst:

Matrix/matrix: Ø70/2x50,8
Zellen/cell: 400 cell
Träger/carrier: beschichtet/coated 50 g/tt3
Beschichtung/coating: Pt:Rh = 5:1
opt.

Träger/carrier: beschichtet/coated 40 g/tt3
Beschichtung/coating: Pt:Rh = 1:1

Remus
Typ HX12
e... ..

Datum	Name	Zeichnungnr	REMUS
Gez.: 16.07.20	TM	20ESD07162.7	Typ: HX12
Gepr.: 16.07.20	VL		

Schalldaempfer/Silencer f. KTM 690 / GasGas 700



Krümmmer Originalteil [1]
manifold, original part

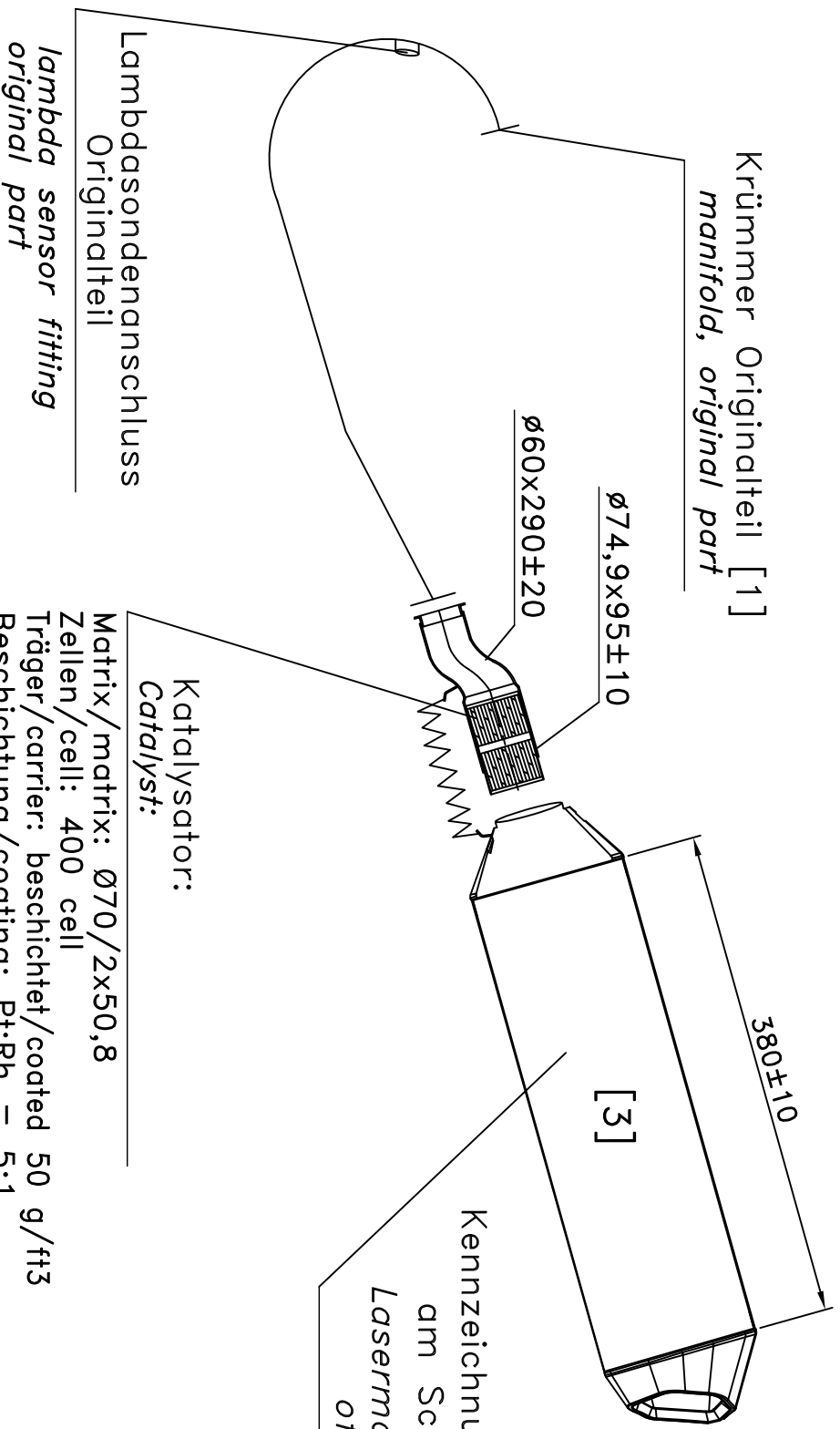

Lambdasondenanschluss
Originalteil
*lambda sensor fitting
original part*

Katalysator:
Catalysf:
Matrix/matrix: Ø70/2x50,8
Zellen/cell: 400 cell
Träger/carrier: beschichtet/coated 50 g/tt3
Beschichtung/coating: Pt:Rh = 5:1
opt.
Träger/carrier: beschichtet/coated 40 g/tt3
Beschichtung/coating: Pt:Rh = 1:1

Kennzeichnung(Laser) seitlich
am Schalldämpfer
Lasermarking at the side
of the silencer

Remus
Typ HX12
E... ..

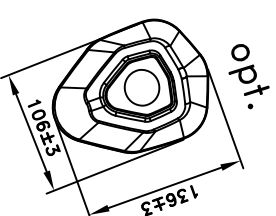
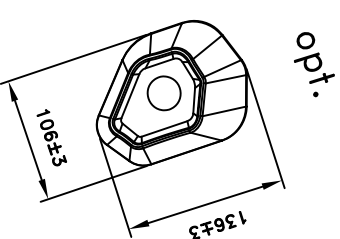
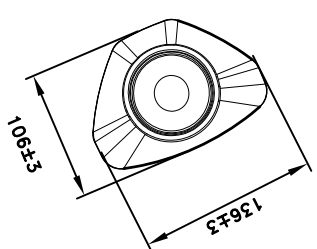

Datum	Name	Zeichnungnr	REMUS
Gez.: 16.07.20	TM	20ESD07162.8	Typ: HX12
Gepr.: 16.07.20	VL		

Schalldämpfer/Silencer f. Husqvarna 701 Supermoto / Enduro,LR



INSTALLATION INSTRUCTIONS

Husqvarna 701 Supermoto | 2020 →

EXHAUST SYSTEM:
Slip-on

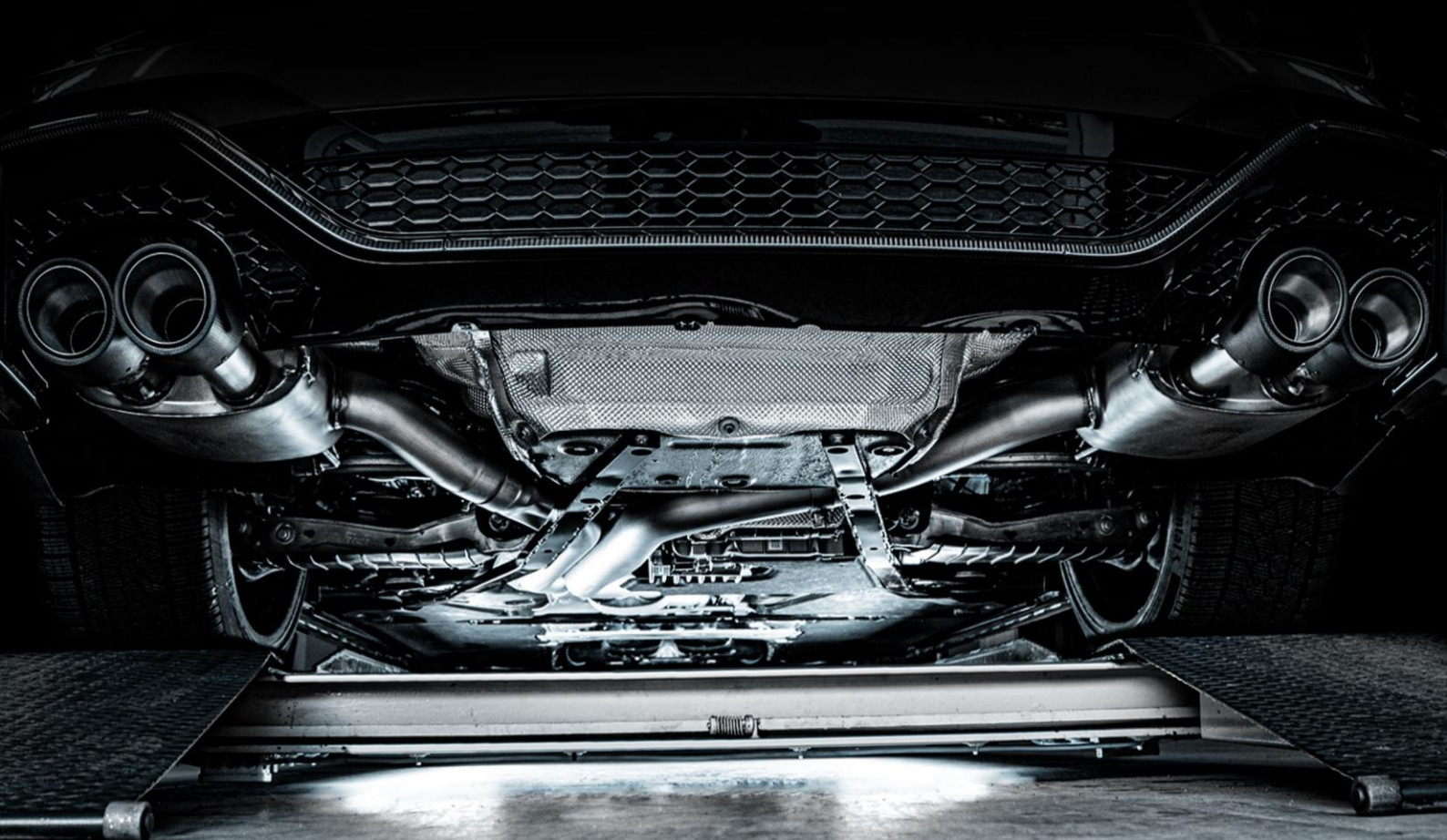

SYMBOLS

The following symbols are used throughout these installation instructions:



TOOLS AND PROTECTIVE EQUIPMENT REQUIRED



TIGHTENING TORQUE



LUBRICATION



HAND TIGHTEN



INSTALLATION TIP



CAUTION OR IMPORTANT



MOVEMENT ARROW



INDICATOR ARROW



CERAMIC PASTE

For lubrication and corrosion protection on screws, bolts, fits and pins. Free of standard and heavy metals, prevents sticking and seizing, neutral to all known sealing materials, non toxic, up to +1400°C heat resistant, short term up to +1600°C, prevents wear and tear.



TOOLS AND EQUIPMENT

Use appropriate safety equipment like eye protection and mechanic gloves! Use appropriate and working tools for mounting and dismantling of the exhaust system.



We congratulate you on buying a product from REMUS and thank you for your trust. We are always striving to offer the very best product for your vehicle through continuous innovation processes and usage of the latest technologies.

READ THIS

Please read this entire installation manual carefully prior to installing and using the REMUS exhaust system.

REMUS exhaust system should only be installed by persons skilled in car/motorcycle exhaust system installation and performance. The instructions provided in this manual should be followed to ensure proper installation and safe use of the REMUS exhaust system. REMUS and/or its partners shall not be held liable for any damage or personal injury (including direct, indirect, or consequential damage) sustained as a result of improper installation of the REMUS exhaust system or its use and maintenance contrary to the instructions and warnings contained herein.

If you have any questions regarding the installation and/or proper use of the REMUS exhaust system or this manual, please contact your local REMUS partner.

For more information on the REMUS exhaust systems, see the official REMUS website at: <http://www.remus.eu>

GENERAL INFORMATION

Your safety is our number one priority. Please drive your car/motorcycle responsibly, safely and always obey local traffic rules.

All statements made with regard to the exhaust system's compliance are made in respect of the exhaust system "as is". Any modifications of the REMUS exhaust system or its improper installation, use or maintenance that is not in accordance with this Installation manual, may result in severe damage to the exhaust system and/ or engine, as well as personal injury, and may affect the exhaust system's compliance with the legal requirements, such as exhaust system's air and/ or noise emissions (as an example, the car/motorcycle may not be suitable for use on public roads any longer), as well as warranty coverage.

The exhaust system may only be used in accordance with relevant laws and regulations, including state and federal, where applicable.

Damage caused by improper installation, use and maintenance of the REMUS exhaust system is not covered by the REMUS warranty. Please refer to the enclosed warranty with regard to the terms of our warranty.

Technical specifications of REMUS exhaust systems and related products are subject to change without notice.



RIGHTS & NOTES

COPYRIGHT, OTHER RIGHTS NOTICE AND GENERAL NOTES

The REMUS trademark, including corporate logos and emblems, are subject to copyright as well as trademark rights of REMUS, its licensors, or third persons authorizing REMUS to use them. Any reproduction, technical or other manipulation, translation, or other use of the copyright and/or trademark rights contained herein is prohibited without the explicit prior written consent of REMUS.

The same especially applies to the entire contents of this manual and/or any of its parts, including but not limited to technical specifications, instructions, graphs, photographs, and so on included in this manual.

The photographs and other illustrations in this manual are symbolic and are intended to help represent individual steps for proper installation and use, as well as for a general overview.

The actual component parts of the REMUS exhaust system may not entirely correspond to the photographs and other illustrations.

REMUS takes all copyright and other rights infringement cases under serious consideration. If you have any reason to believe that your exhaust system is not an original REMUS product, please contact our local partners or REMUS at office@remus.at



SAFETY WARNINGS

IMPORTANT SAFETY WARNINGS, PLEASE READ CAREFULLY

The car/motorcycle should be in the off position throughout the whole dismantling and mounting process, as well as any other work done on the exhaust system!

Before dismantling the exhaust system, lock the car/motorcycle and remove the key from the vehicle to avoid electrical errors in the control units!

For proper dismantling and mounting of the exhaust system, it is recommended to use an certificated and tested lifting device.

The exhaust system can get extremely hot during and after it is used. Allow the exhaust and engine to cool down before touching it and beginning installation.

Make sure that you have all the parts necessary for the installation of your new REMUS exhaust system, according to the parts list in this manual. If any of the parts are missing, please do not proceed with uninstalling your stock exhaust system/installing the REMUS exhaust system and contact the retailer you bought the REMUS exhaust system from.

CAUTION: make sure not to injure yourself or damage any part of the vehicle during dismantling and mounting of the exhaust systems!

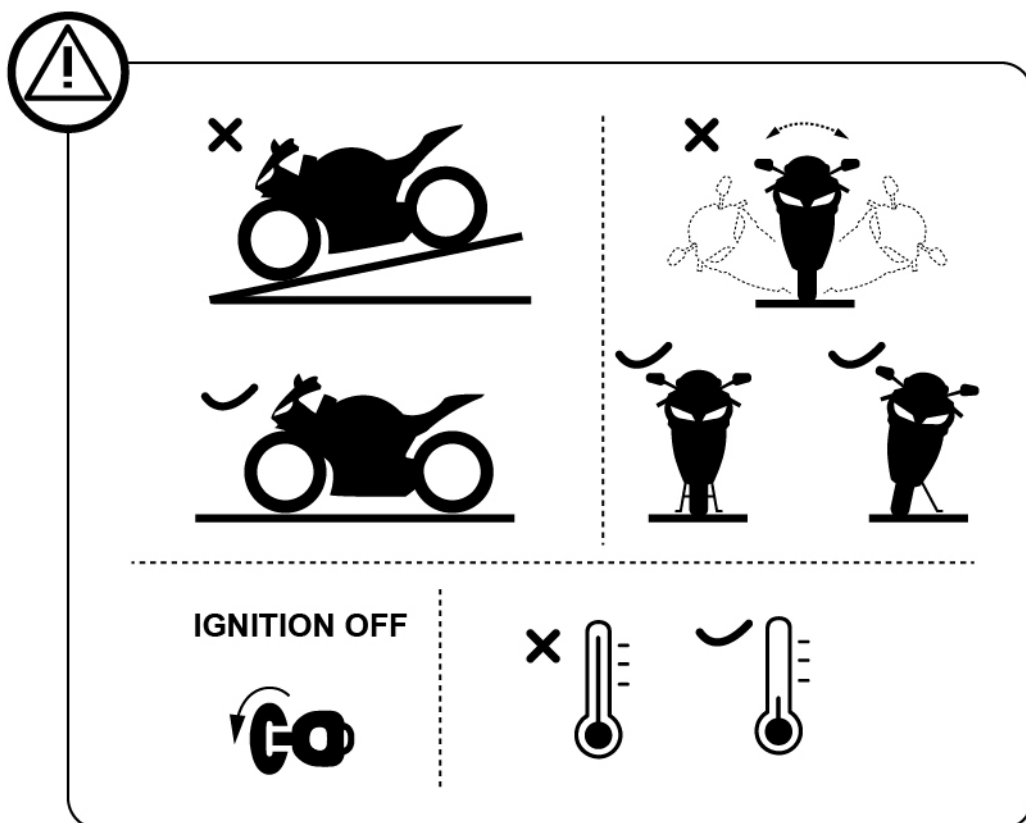

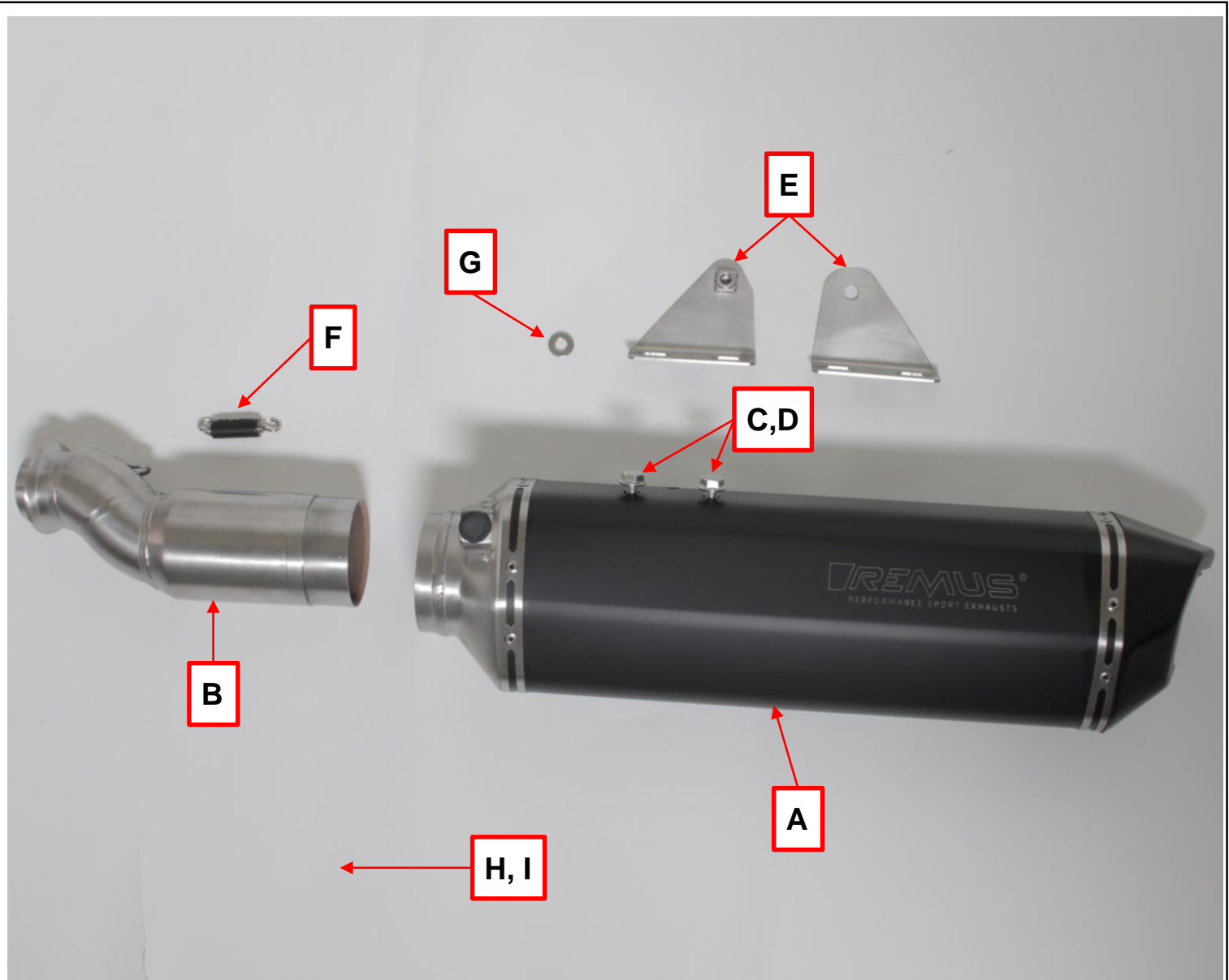

pos	pcs	packing content
A	1	sport exhaust
B	1	connection tube
C	4	hex socket screw M8x16 mm (pre mounted)
D	4	washer M8 (pre mounted)
E	2	bracket
F	1	spring
G	1	washer M8 Ø18mm
H	1	ceramic paste
I	1	pair of gloves

REMOVAL

OF STOCK EXHAUST SYSTEM:

The process of uninstalling the original exhaust system may vary depending on the existing exhaust system. Please follow the original exhaust system manufacturer's instructions for uninstalling the original exhaust system.

If you for any reason decide otherwise, please note that any information provided in this respect herein should be considered as general information provided for your convenience only.

REMUS shall not assume any liability or responsibility with regard to uninstalling your existing exhaust system, warranty coverage of such exhaust system or vehicle or their further fitness for use.



REMOVAL OF STOCK EXHAUST SYSTEM:



Remove the seat.
In the next step remove the rear side covering.

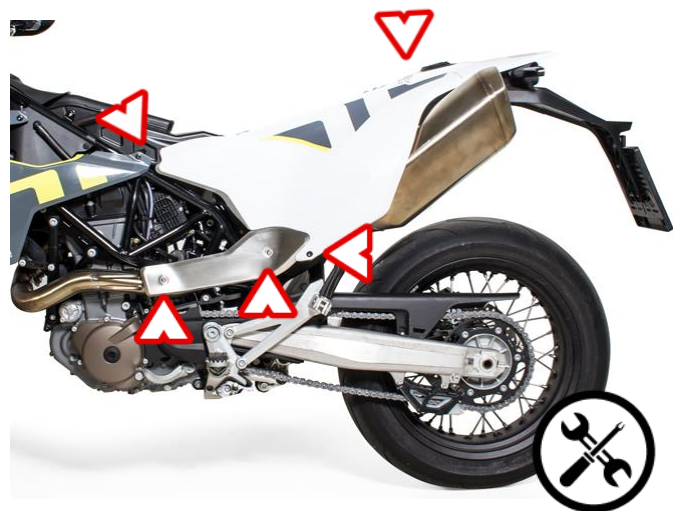



Loosen the bracket's screw and the clamp of the serial muffler and remove the muffler.

 **Make sure to leave the stock gasket in place!**

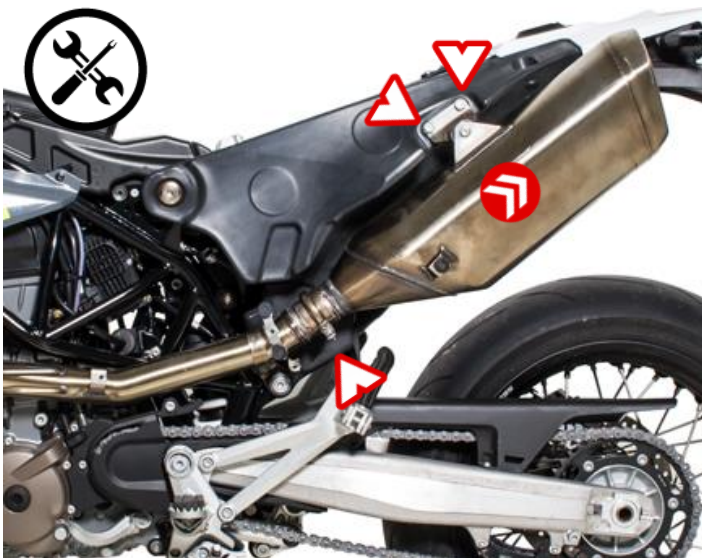

INSTALLATION OF THE REMUS EXHAUST SYSTEM

Mount the supplied brackets on the REMUS sport exhaust.

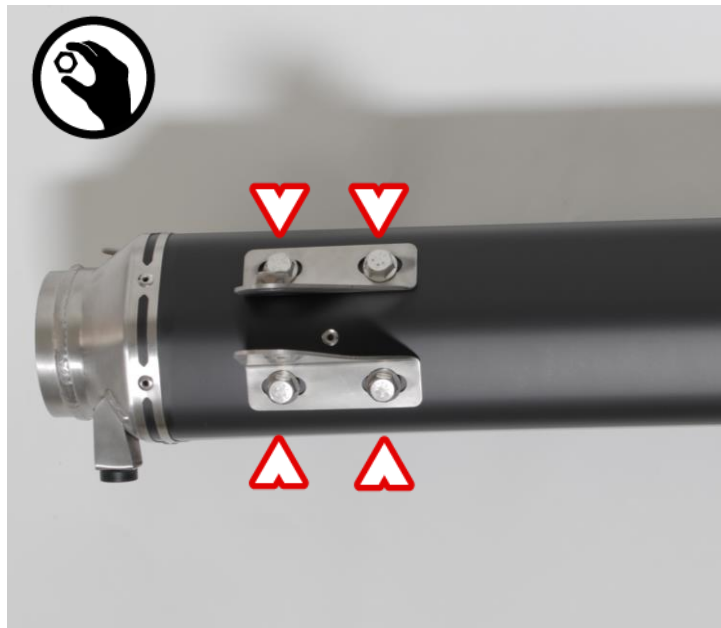

Remove the stock bracket and mount it onto the REMUS sport exhaust.

 **Use the supplied washer**

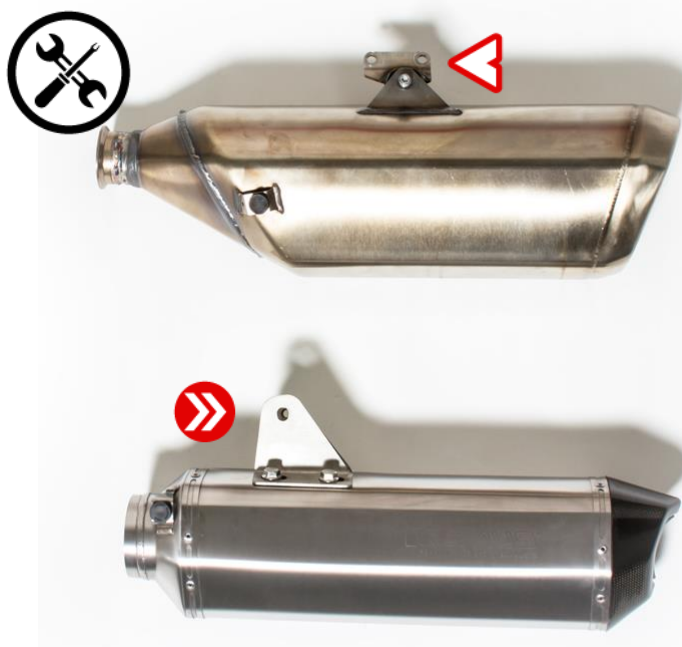

Slip on the REMUS connection tube to the REMUS sport exhaust.

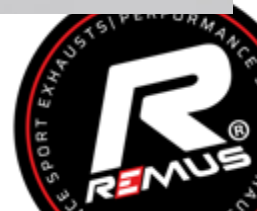

Slip on the REMUS sport exhaust on the standard header, use the standard sealing. Slightly tighten the bracket's screws and the clamp.



Hook in the REMUS spring.



Align the REMUS sport exhaust and tighten all connections.

25 Nm
18 ftlb



8 Nm
6 ftlb



Remount all **removed stock parts**.



10 Nm
7 ftlb



10 Nm
7 ftlb



5 Nm
4 ftlb



FINAL STEPS

IMPORTANT: reinstall the dismantled or partially removed stock parts (wheel arches, bumper etc.); check vehicle manufacturer manual for tightening torques.

IMPORTANT: make sure all the nuts and bolts are sufficiently tightened. In case the exhaust system touches the cowling or other parts, repeat the adjustment of the exhaust system or contact your authorized dealer.

IMPORTANT: clean all exhaust components before the first start of the engine or the stains will burn onto the surfaces!

TROUBLESHOOTING

Problem	Possible cause	Solution
Exhaust gas is leaking out of the exhaust system	loosened clamp	tighten all connections to specified torque
	connection is not completely joined	loosen the connection and tap it into place, tighten the connection to specified torque
Valve is not working / moving	Valve is mechanical stuck	Remove the actuator and try to move the valve by hand. Use spray lubricant (WD-40® or equivalent) to make the valve working again.
	Valve is not working correct	Make sure the actuator is powered correctly. Make sure the actuator is mounted properly onto the valve and the valve spins correctly.
Exhaust system rattles / doesn't fit properly	Exhaust System is not mounted correct	loosen all connections again and readjust/align the whole system once more



MAINTENANCE

STAINLESS STEEL PARTS:

Clean stainless steel components with soft cloth sprayed with contact cleaner, then wipe with soft and dry cloth.

CARBON PARTS:

Clean carbon fiber exhaust components with soft and dry cloth.

TITANIUM PARTS:

Clean the titanium exhaust components with a multi-purpose spray lubricant (WD-40® or equivalent).

A change in the color of the exhaust system is normal due to high temperatures. Periodically make sure all the bolts and springs are sufficiently tight.



IT IS NORMAL FOR WHITE SMOKE TO COME OUT OF THE MUFFLER AT FIRST OPERATION.

⚠ CAUTION: DO NOT STAND BEHIND THE MUFFLER AT ANY TIME.

⚠ CAUTION: DO NOT USE AUTOMOTIVE WHEEL CLEANERS OR ANY CLEANING PRODUCTS WHICH CONTAIN ACIDIC ADDITIVES TO CLEAN THE REMUS EXHAUST SYSTEMS.



THE SOUND OF **REMUS**®

FIRST CLASS QUALITY DESIGNED & BUILT IN EUROPE | AUSTRIA

www.remus.eu

 **REMUS Innovation GmbH**
Ruhmannstraße 11
A-8570 Voitsberg



TOOLS AND PROTECTIVE EQUIPMENT REQUIRED



TIGHTENING TORQUE



LUBRICATION



HAND TIGHTEN



INSTALLATION TIP



CAUTION OR IMPORTANT



MOVEMENT ARROW



INDICATOR ARROW



CERAMIC PASTE

For lubrication and corrosion protection on screws, bolts, fits and pins. Free of standard and heavy metals, prevents sticking and seizing, neutral to all known sealing materials, non toxic, up to +1400°C heat resistant, short term up to +1600°C, prevents wear and tear.



TOOLS AND EQUIPMENT

Use appropriate safety equipment like eye protection and mechanic gloves! Use appropriate and working tools for mounting and dismantling of the exhaust system.



INSTALLATION INSTRUCTIONS

KTM 690 SMC-R | 2020 →

EXHAUST SYSTEM:
Slip-on



SYMBOLS

The following symbols are used throughout these installation instructions:



TOOLS AND PROTECTIVE EQUIPMENT REQUIRED



TIGHTENING TORQUE



LUBRICATION



HAND TIGHTEN



INSTALLATION TIP



CAUTION OR IMPORTANT



MOVEMENT ARROW



INDICATOR ARROW



CERAMIC PASTE

For lubrication and corrosion protection on screws, bolts, fits and pins. Free of standard and heavy metals, prevents sticking and seizing, neutral to all known sealing materials, non toxic, up to +1400°C heat resistant, short term up to +1600°C, prevents wear and tear.



TOOLS AND EQUIPMENT

Use appropriate safety equipment like eye protection and mechanic gloves! Use appropriate and working tools for mounting and dismounting of the exhaust system.



We congratulate you on buying a product from REMUS and thank you for your trust. We are always striving to offer the very best product for your vehicle through continuous innovation processes and usage of the latest technologies.

READ THIS

Please read this entire installation manual carefully prior to installing and using the REMUS exhaust system.

REMUS exhaust system should only be installed by persons skilled in car/motorcycle exhaust system installation and performance. The instructions provided in this manual should be followed to ensure proper installation and safe use of the REMUS exhaust system. REMUS and/or its partners shall not be held liable for any damage or personal injury (including direct, indirect, or consequential damage) sustained as a result of improper installation of the REMUS exhaust system or its use and maintenance contrary to the instructions and warnings contained herein.

If you have any questions regarding the installation and/or proper use of the REMUS exhaust system or this manual, please contact your local REMUS partner.

For more information on the REMUS exhaust systems, see the official REMUS website at: <http://www.remus.eu>

GENERAL INFORMATION

Your safety is our number one priority. Please drive your car/motorcycle responsibly, safely and always obey local traffic rules.

All statements made with regard to the exhaust system's compliance are made in respect of the exhaust system "as is". Any modifications of the REMUS exhaust system or its improper installation, use or maintenance that is not in accordance with this Installation manual, may result in severe damage to the exhaust system and/ or engine, as well as personal injury, and may affect the exhaust system's compliance with the legal requirements, such as exhaust system's air and/ or noise emissions (as an example, the car/motorcycle may not be suitable for use on public roads any longer), as well as warranty coverage.

The exhaust system may only be used in accordance with relevant laws and regulations, including state and federal, where applicable.

Damage caused by improper installation, use and maintenance of the REMUS exhaust system is not covered by the REMUS warranty. Please refer to the enclosed warranty with regard to the terms of our warranty.

Technical specifications of REMUS exhaust systems and related products are subject to change without notice.



RIGHTS & NOTES

COPYRIGHT, OTHER RIGHTS NOTICE AND GENERAL NOTES

The REMUS trademark, including corporate logos and emblems, are subject to copyright as well as trademark rights of REMUS, its licensors, or third persons authorizing REMUS to use them. Any reproduction, technical or other manipulation, translation, or other use of the copyright and/or trademark rights contained herein is prohibited without the explicit prior written consent of REMUS.

The same especially applies to the entire contents of this manual and/or any of its parts, including but not limited to technical specifications, instructions, graphs, photographs, and so on included in this manual.

The photographs and other illustrations in this manual are symbolic and are intended to help represent individual steps for proper installation and use, as well as for a general overview. The actual component parts of the REMUS exhaust system may not entirely correspond to the photographs and other illustrations.

REMUS takes all copyright and other rights infringement cases under serious consideration. If you have any reason to believe that your exhaust system is not an original REMUS product, please contact our local partners or REMUS at office@remus.at



SAFETY WARNINGS

IMPORTANT SAFETY WARNINGS, PLEASE READ CAREFULLY

The car/motorcycle should be in the off position throughout the whole dismantling and mounting process, as well as any other work done on the exhaust system!

Before dismantling the exhaust system, lock the car/motorcycle and remove the key from the vehicle to avoid electrical errors in the control units!

For proper dismantling and mounting of the exhaust system, it is recommended to use an certificated and tested lifting device.

The exhaust system can get extremely hot during and after it is used. Allow the exhaust and engine to cool down before touching it and beginning installation.

Make sure that you have all the parts necessary for the installation of your new REMUS exhaust system, according to the parts list in this manual. If any of the parts are missing, please do not proceed with uninstalling your stock exhaust system/installing the REMUS exhaust system and contact the retailer you bought the REMUS exhaust system from.

CAUTION: make sure not to injure yourself or damage any part of the vehicle during dismantling and mounting of the exhaust systems!

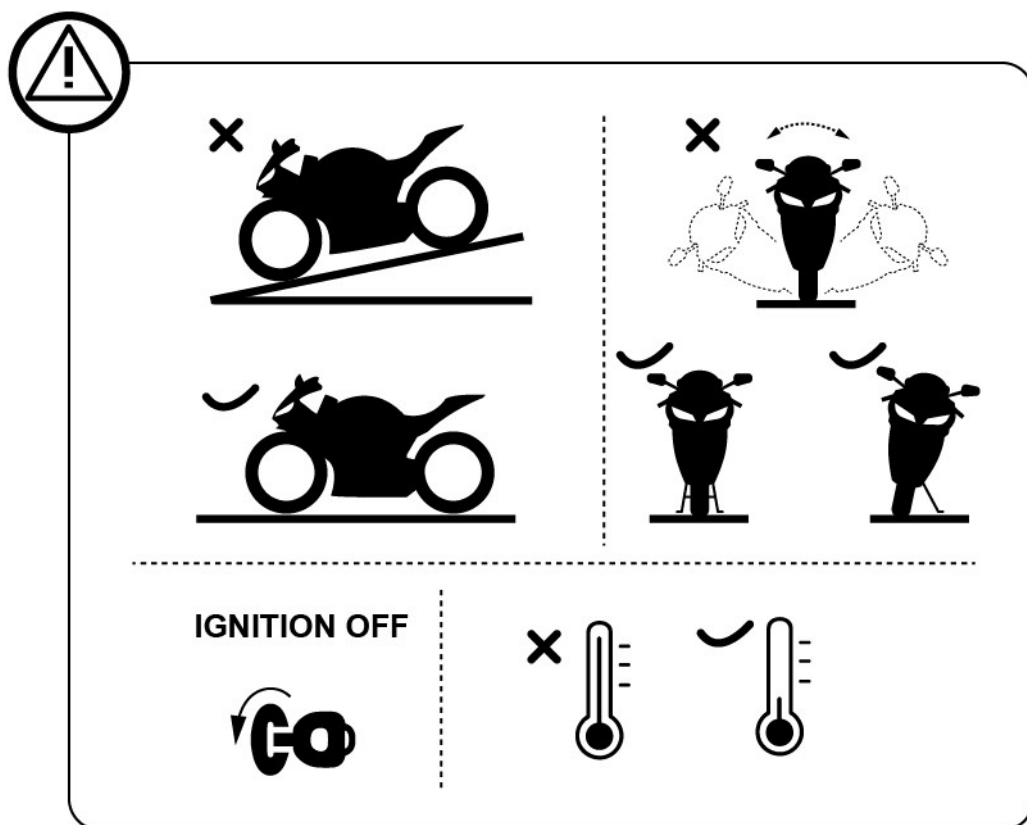

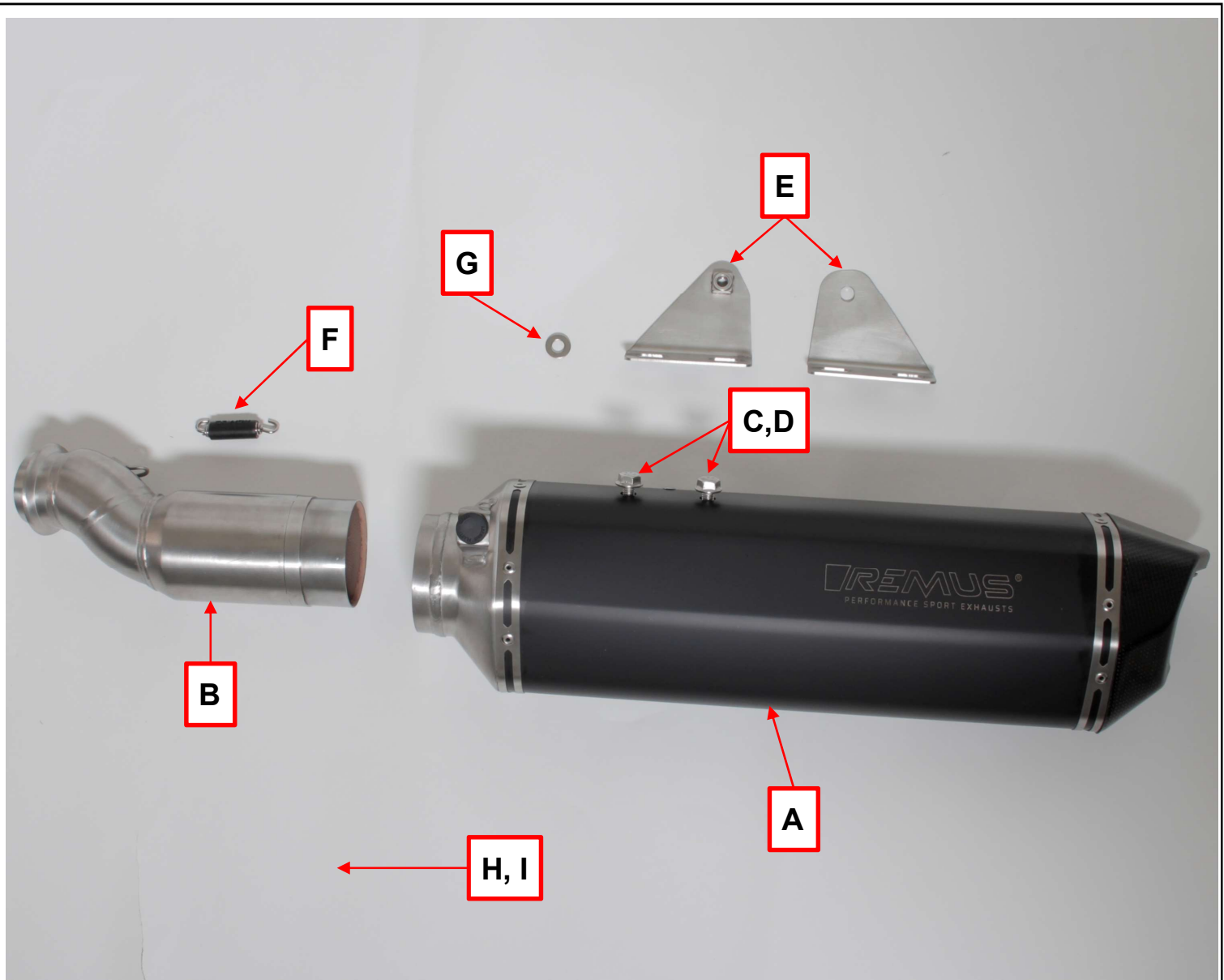

pos	pcs	packing content
A	1	sport exhaust
B	1	connection tube
C	4	hex socket screw M8x16 mm (pre mounted)
D	4	washer M8 (pre mounted)
E	2	bracket
F	1	spring
G	1	washer M8 Ø18mm
H	1	ceramic paste
I	1	pair of gloves

REMOVAL

OF STOCK EXHAUST SYSTEM:

The process of uninstalling the original exhaust system may vary depending on the existing exhaust system. Please follow the original exhaust system manufacturer's instructions for uninstalling the original exhaust system.

If you for any reason decide otherwise, please note that any information provided in this respect herein should be considered as general information provided for your convenience only.

REMUS shall not assume any liability or responsibility with regard to uninstalling your existing exhaust system, warranty coverage of such exhaust system or vehicle or their further fitness for use.



REMOVAL OF STOCK EXHAUST SYSTEM:



Remove the seat and the front side covering.
In the next step remove the rear side covering.





Loosen the bracket's screw and the clamp of the serial muffer and remove the muffer.



INSTALLATION OF THE REMUS EXHAUST SYSTEM

Mount the supplied brackets on the REMUS sport exhaust.

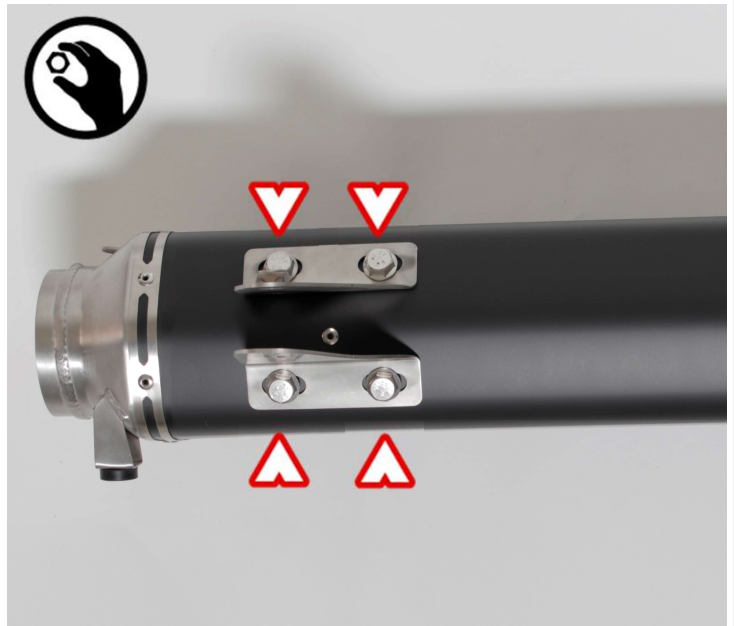

Remove the stock bracket and mount it onto the REMUS sport exhaust.

 **Use the supplied washer**

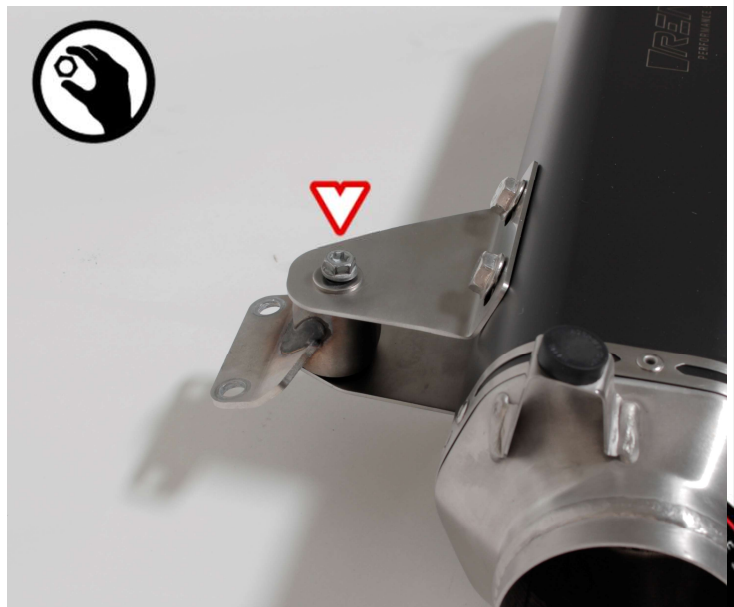

Mount the stock gasket on the REMUS connection tube.

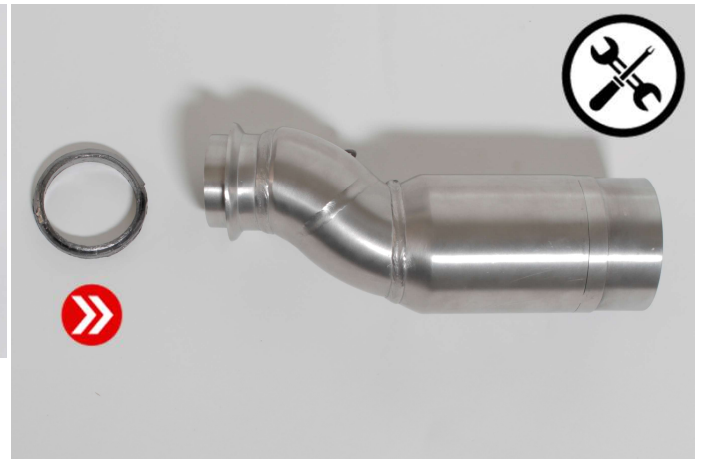

Slip on the REMUS connection tube to the REMUS sport exhaust.



Slip on the REMUS sport exhaust on the standard header, use the standard sealing. Slightly tighten the bracket's screws and the clamp.



Hook in the REMUS spring.



Align the REMUS sport exhaust and tighten all connections.

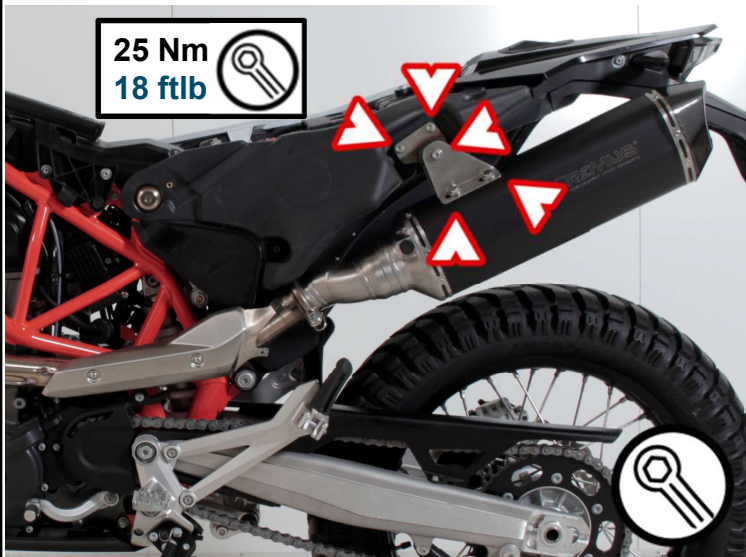

Remount all removed stock parts.

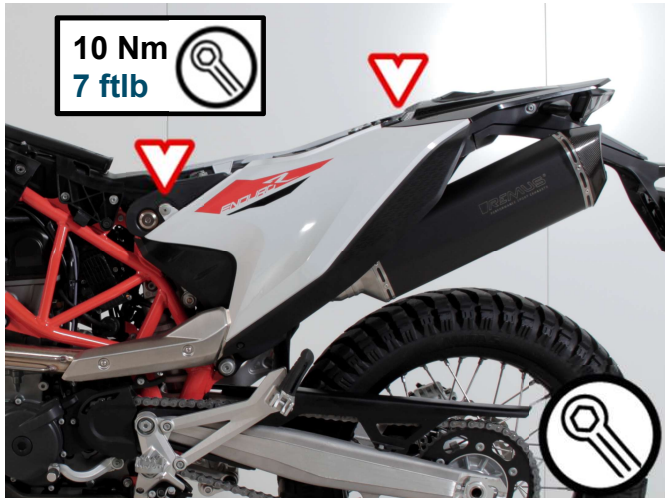

FINAL STEPS

IMPORTANT: reinstall the dismantled or partially removed stock parts (wheel arches, bumper etc.); check vehicle manufacturer manual for tightening torques.

IMPORTANT: make sure all the nuts and bolts are sufficiently tightened. In case the exhaust system touches the cowling or other parts, repeat the adjustment of the exhaust system or contact your authorized dealer.

IMPORTANT: clean all exhaust components before the first start of the engine or the stains will burn onto the surfaces!

TROUBLESHOOTING

Problem	Possible cause	Solution
Exhaust gas is leaking out of the exhaust system	loosened clamp	tighten all connections to specified torque
	connection is not completely joined	loosen the connection and tap it into place, tighten the connection to specified torque
Valve is not working / moving	Valve is mechanical stuck	Remove the actuator and try to move the valve by hand. Use spray lubricant (WD-40® or equivalent) to make the valve working again.
	Valve is not working correct	Make sure the actuator is powered correctly. Make sure the actuator is mounted properly onto the valve and the valve spins correctly.
Exhaust system rattles / doesn't fit properly	Exhaust System is not mounted correct	loosen all connections again and readjust/ align the whole system once more



MAINTENANCE

STAINLESS STEEL PARTS:

Clean stainless steel components with soft cloth sprayed with contact cleaner, then wipe with soft and dry cloth.

CARBON PARTS:

Clean carbon fiber exhaust components with soft and dry cloth.

TITANIUM PARTS:

Clean the titanium exhaust components with a multi-purpose spray lubricant (WD-40® or equivalent).

A change in the color of the exhaust system is normal due to high temperatures. Periodically make sure all the bolts and springs are sufficiently tight.



IT IS NORMAL FOR WHITE SMOKE TO COME OUT OF THE MUFFLER AT FIRST OPERATION.

⚠ CAUTION: DO NOT STAND BEHIND THE MUFFLER AT ANY TIME.

⚠ CAUTION: DO NOT USE AUTOMOTIVE WHEEL CLEANERS OR ANY CLEANING PRODUCTS WHICH CONTAIN ACIDIC ADDITIVES TO CLEAN THE REMUS EXHAUST SYSTEMS.



THE SOUND OF REMUS®

FIRST CLASS QUALITY DESIGNED & BUILT IN EUROPE | AUSTRIA

www.remus.eu

 REMUS Innovation GmbH
Ruhmannstraße 11
A-8570 Voitsberg



TOOLS AND PROTECTIVE EQUIPMENT REQUIRED



TIGHTENING TORQUE



LUBRICATION



HAND TIGHTEN



INSTALLATION TIP



CAUTION OR IMPORTANT



MOVEMENT ARROW



INDICATOR ARROW



CERAMIC PASTE

For lubrication and corrosion protection on screws, bolts, fits and pins. Free of standard and heavy metals, prevents sticking and seizing, neutral to all known sealing materials, non toxic, up to +1400°C heat resistant, short term up to +1600°C, prevents wear and tear.



TOOLS AND EQUIPMENT

Use appropriate safety equipment like eye protection and mechanic gloves! Use appropriate and working tools for mounting and dismounting of the exhaust system.

