

## EU TYPE-APPROVAL CERTIFICATE

Communication concerning: ~~EU type approval<sup>(4)</sup>~~  
~~Extension of EU type-approval<sup>(1)</sup>~~  
~~Refusal of EU type approval<sup>(1)</sup>~~  
~~Withdrawal of EU type approval<sup>(1)</sup>~~

of a type of ~~component~~/separate technical unit<sup>(1)(0)</sup> pollution-control device and noise-abatement device with regard to Annex(es) IX <sup>(a)</sup> to Commission Delegated Regulation (EU) No 134/2014 ~~(and Annex(es) ...<sup>(a)</sup> to Commission Delegated Regulation (EU) No .../...)~~<sup>(1)</sup>, as last amended by (Commission Delegated) <sup>(1)</sup> Regulation (EU) No 2018/295 <sup>(1)(6)</sup>

EU type-approval number<sup>(1)</sup>: **e24\*134/2014\*2018/295G\*00307\*02**

Reason for extension<sup>(1)</sup>: **- Extension of the range of Application**

### SECTION I

- 0.7. Make(s) (trade name(s) of manufacturer): **REMUS**
- 0.8. Type: **HX13**
- 0.8.1. Commercial name(s) (if available): **N/A**
- 0.9. Company name and address of the manufacturer: **Remus Innovation GmbH  
Ruhmannstraße 11  
A-8570 Voitsberg**
- 0.9.1. Name(s) and address(es) of assembly plant(s): **Remus Innovation  
Forschungs- und  
Abgasanlagen Produktions  
GmbH Dr. Niederdorferstraße  
25 A-8572 Bärnbach**  
**Remus Innovation GmbH  
Ruhmannstraße 11  
A-8570 Voitsberg**
- 0.9.2. Name and address of the manufacturer's representative (if any): **N/A**
- 0.10. In the case of separate technical unit, vehicle(s) for which is intended for <sup>(b)</sup>:
- 0.10.1. Type<sup>(c)</sup>: **See test report  
20-TAHO-0148/E2/SCST for  
details**
- 0.10.2. Variant(s)<sup>(c)</sup>: **See test report  
20-TAHO-0148/E2/SCST for  
details**
- 0.10.3. Version(s)<sup>(c)</sup>: **See test report  
20-TAHO-0148/E2/SCST for  
details**

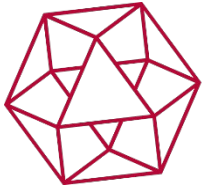

# NSAI

EU type-approval number(1): **e24\*134/2014\*2018/295G\*00307\*02**

0.10.4. Commercial name(s) (if available): *See test report  
20-TAHO-0148/E2/SCST for  
details*

0.10.5. Category, subcategory and sub-subcategory of vehicle (3): **L3e-A3**

## SECTION II

1. Technical service responsible for carrying out the tests: **D TÜV AUSTRIA  
AUTOMOTIVE GMBH  
Deutschstraße 10  
A-1230 Wien**

2. Date of test report(s): *As before and 24.04.2023*

3. Number of test report(s): *Current: 20-TAHO-0148/E2/SCST  
Previous: 20-TAHO-0148/E1/KIV  
20-TAHO-0148/KIV*

4. Remarks (see addendum): *N/A*

5. Restrictions of validity <sup>(1)(4)</sup>: *N/A*

6. Waivers applied <sup>(1)(4)</sup>: *N/A*

Place:  *Dublin*

Date:  *08<sup>th</sup> May, 2023*

Name and signature (or visual representation of an 'advanced electronic signature' according to Directive 1999/93/EC, including data for verification):

### Attachments:

- Information package
- Test report

### NB:

— If this model is used for type-approval of a component or separate technical unit as an exemption for new technology or new concept, pursuant to Article 40 of Regulation (EU) No 168/2013, the heading of the certificate shall read 'EU PROVISIONAL TYPE-APPROVAL CERTIFICATE VALID ONLY ON THE TERRITORY OF ... <sup>(4)</sup>', The provisional type approval certificate shall also specify the restrictions that have been imposed as to its validity and the waivers which have been applied in accordance with Article 30<sup>(4)</sup> of Regulation (EU) No 168/2013.

### Explanatory notes relating to Appendix 5

(Footnotes and explanations not to be stated on the type-approval certificate)

<sup>(0)</sup> Indicate the component/separate technical unit according to first column of Table 1 in point 6 of Annex VII (e.g. devices to prevent unauthorised use)

<sup>(1)</sup> Delete where not applicable.

<sup>(3)</sup> Classified according to Article 4 of and Annex I to Regulation (EU) No 168/2013, the coding shall be indicated, e.g. "L3e-A1E" for a low-performance Enduro motor-cycle.

<sup>(4)</sup> Indicate the Member State.

<sup>(5)</sup> Applicable only for type-approval of a component or separate technical unit as an exemption for new technology or new concept, pursuant to Article 40 of Regulation (EU) No 168/2013

<sup>(6)</sup> Indicate the latest amendment of the Commission Delegated Regulation according to the amendment applied for the EU type-approval.

<sup>(a)</sup> The Roman numeral of the relevant Annex to the Commission Delegated Regulation or multiple Roman numerals of the relevant Annexes to the same Commission Delegated Regulation.

<sup>(b)</sup> Provide this information for each vehicle type.

<sup>(c)</sup> Indicate the alphanumeric code Type-Variant-Version or 'TVV' allocated to each type, variant and version as set out in point 2.3 of Part B of Annex I.

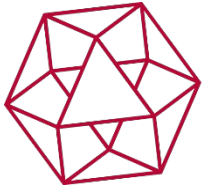

# NSAI

ADDENDUM TO THE EU TYPE-APPROVAL CERTIFICATE WITH EU TYPE-APPROVAL NUMBER  
*e24\*134/2014\*2018/295G\*00307\*02*

- |  |                               |
|--|-------------------------------|
| 1. Restriction of use of the <sup>(0)</sup> ( <sup>1</sup> ):                  | <i>Noise-abatement device</i> |
| ( <sup>2</sup> ):  | <i>N/A</i>                    |
| 2. Special conditions for the mounting of the <sup>(0)</sup> ( <sup>1</sup> ): | <i>Noise-abatement device</i> |
| ( <sup>2</sup> ):  | <i>N/A</i>                    |
| 3. Remarks <sup>(0)</sup> :  | <i>N/A</i>                    |

#### Explanatory notes relating to Appendix 6

(Footnotes and explanations not to be stated on the addendum to the type-approval certificate)

<sup>(0)</sup> Delete where not applicable.

<sup>(1)</sup> Identify the component or separate technical unit according to the first column of Table 1 in point 6 of Annex VII to this Regulation (e.g. devices to prevent unauthorised use).

<sup>(2)</sup> In accordance with Article 31(4) of Regulation (EU) No 168/2013, indicate the restrictions of use and the special conditions for the mounting of the component/separate technical unit.

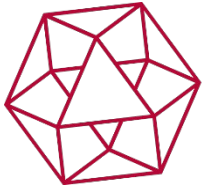

# NSAI

EU type-approval number:

*e24\*134/2014\*2018/295G\*00307\*02*

## *Index to the Information Package*

Date of issue:	<i>11<sup>th</sup> January, 2021</i>
Date of latest amendment:	<i>08<sup>th</sup> May, 2023</i>
Reason for extension/revision:	<i>- Extension of the range of Application</i>
1. Additional conditions, and advisory notes on legal alternatives	
2. Test report(s)	
- numbers(s):	<i>Current: 20-TAHO-0148/E2/SCST Previous: 20-TAHO-0148/E1/KIV 20-TAHO-0148/KIV</i>
- date of issue:	<i>18.12.2020</i>
- date of latest amendment:	<i>24.04.2023</i>
3. Information document	
- number(s):	<i>HX13 up to /02</i>
- date of issue:	<i>06.10.2020</i>
- date of latest amendment:	<i>07.02.2023</i>
Documentation:	<i>57 pages</i>



EU type-approval number:

e24\*134/2014\*2018/295G\*00307\*02

**Appendix: Additional conditions, and advisory notes on legal alternatives**

A: Additional conditions:

1. The attached technical report, with any of its attachments, forms part of this Type Approval certificate.
2. Each type from series production shall be to the measurements specified in the attached drawings, and shall be manufactured only from the materials specified in the Approval documents.
3. Changes in the type are permitted only with the explicit permission of NSAI. Breaches of this requirement will lead to a withdrawal of the Type Approval, and in addition may be subject to criminal prosecution.
4. At regular intervals, any tests or associated checks prescribed by the applicable legislation to verify continued conformity with the approved type shall be carried out. The manufacturer shall demonstrate compliance with this by submitting to NSAI evidence of adequate arrangements and documented control plans for each type approved.
5. Any set of samples or test pieces showing evidence of non-conformity shall give rise to further sampling and testing and all steps shall be taken to restore conformity of production.
6. This Type Approval will expire when it is surrendered by the holder, or withdrawn by NSAI, or when the approved type no longer conforms to legal requirements. The recall of the Type Approval can be issued by NSAI when the conditions required for the issuing or continuation of the Type Approval are no longer current, or when the Approval holder is in breach of the duties attached to the Type Approval, or when it is established that the approved type no longer meets the requirements of traffic safety.
7. Changes in the company name, address or manufacturing site, as well as in any of the sales or other agents specified in the issuing of the approval must immediately be notified to NSAI.
8. The duties imposed by the issuing of this certificate are not transferable. The legal protection of third parties is not affected by this certificate.
9. When the manufacture or sale of the system, component or separate technical unit has not been started within one year of the date of issue of this certificate, then NSAI is to be informed. This requirement also applies when the manufacture or sale has been halted for more than one year, or when it ought to have been halted for more than one year. The initial commencement of manufacture or sale, or the resumption of manufacture or sale, shall then be notified to NSAI within one month of commencement or resumption.

B: Legal Options:

Any objection to the requirements set out in this certificate shall be made within one month of the date of issue. The objection shall be made, in writing, to NSAI in Dublin.

# Prüfbericht

## Test Report

### 20-TAHO-0148/E2/SCST

**Einheitliche Bedingungen für die Genehmigung von nicht originalen Austauschschalldämpfern (NORESS) für Fahrzeuge der Klassen L1, L2, L3, L4 und L5 hinsichtlich der Geräuschemissionen**  
*Uniform provisions concerning the approval of non-original replacement exhaust silencing systems (RESS) for motorcycles, mopeds and three-wheeled vehicles*

<b>Gemäß Verordnung/Richtlinie</b> <i>According to Regulation/Directive</i>	
<input type="checkbox"/>	UN ECE R92 Änderungsserie 01 einschl. Ergänzung 2 <i>UN ECE R92.01 Series of amendments including supplement 2</i>
<input checked="" type="checkbox"/>	VO (EU) 134/2014 Anhang IX Anlage 2 einschließlich aller Änderungen bis 2018/295 <i>Regulation (EU) 134/2014 Annex IX appendix 2 including amendments until 2018/295</i>

<b>Genehmigungsstand</b> <i>approval status</i>	
<input type="checkbox"/>	Erteilung einer Typgenehmigung <i>Granting of a type approval</i>
<input checked="" type="checkbox"/>	Erweiterung der Typgenehmigung e24*134/2014*2018/295G*00307*01 *) <i>Extension to a type approval e24*134/2014*2018/295G*00307*01</i>
<input type="checkbox"/>	Änderung zur Typgenehmigung *) <i>Correction of a type approval</i>

<b>*Bemerkungen / Remarks</b>  <b>- Erweiterung des Verwendungsbereiches*</b> <i>Extension of the range of application*</i>
--

Änderungen sind blau markiert  
*Changes are marked blue*

## 0. Allgemeine Angaben

### General information

- 0.1 Fabrikmarke : Remus  
*Trademark*
- 0.2 Typ : HX13  
*Type*
- 0.3 Varianten und Versionen : Siehe Beschreibungsbogen  
*Variants and Versions See Information Document*
- 0.4 Name und Anschrift des Herstellers : Remus Innovation GmbH  
*Name and address of manufacturer*  
Ruhmannstraße 11  
A-8570 Voitsberg
- 0.5 Beschreibungsbogen Nr. : HX13/02  
*Information document No.*
- 0.5.1 Ausgabedatum : 07.02.2023  
*Issue date*
1. Verwendungsbereich : Siehe Anlage 1  
*Range of application See Annex 1*
2. Angaben zum Prüfobjekt : Siehe Beschreibungsbogen  
*Details of the test subject See Information Document*
- 2.1 Art des Ersatzschalldämpfers : Siehe Beschreibungsbogen gemäß Punkt 0.5  
*Type of replacement muffler see Information Document according to 0.5*
- 2.2 Lage, Anzahl und Richtung des Endrohre : Fahrzeugende hinten, rechts  
*Position, number and direction of the tail pipe(s) Rear side of the vehicle, right*
3. Prüfprotokoll  
*Test protocol*
- Die Prüfungen wurden mit folgendem(n) : Fahrzeug Nr. #5  
Fahrzeug(en) durchgeführt : #8  
*Test have been carried out with the following vehicle(s) Vehicle number*
- Verwendeter Austauschschalldämpfer : Remus / HX13  
*Muffler used*

**3.1.1 Fahrzeug #5**  
**Vehicle #5**

- 3.1.1.1 Hersteller : KTM  
Manufacturer
- 3.1.1.2 Typ : KTM 790 Adventure  
Type
- 3.1.1.3 Variante/Version : B / -  
Variant/Version
- 3.1.1.4 Genehmigungsnummer : e1\*168/2013\*00149\*..  
Homologation no.
- 3.1.1.5 Fahrzeugidentifizierungsnummer : VBKTR3409KM750618  
Vehicle identification number
- 3.1.1.6 Baujahr : 2019  
Year of manufacture
- 3.1.1.7 Kilometerstand : 2563  
Mileage (km)

**3.1.2 Antriebsaggregat**  
**Engine**

- 3.1.2.1 Hersteller : KTM  
Manufacturer
- 3.1.2.2 Typ : 635  
Type
- 3.1.2.3 Nennleistung [kW @ min-1] : 70 @ 8250  
Rated maximum engine power
- 3.1.2.4 Hubraum [cm<sup>3</sup>] : 799  
Cubic capacity

**3.1.3 Kraftübertragung**  
**Transmission**

- 3.1.3.1 Technische Zeichnung des Kraftübertragungssystems : Siehe Fahrzeugtypgenehmigung gemäß 3.1.4  
Tech. Drawing of the power transmission system See WVTA according to 3.1.4
- 3.1.3.2 Art der Kraftübertragung :  mechanisch / mechanic  
Type of power transmission  hydraulisch / hydraulic  
 elektrisch / electric

3.1.3.3 Art des Getriebes :  manuell / manual  
Type of gearbox  automatisch / automatic  
 stufenlos / CVT

3.1.3.4 Getriebeübersetzungen  
Gear ratios

Primär I : 2,85  
primary II : 2,00  
III : 1,55  
IV : 1,27  
V : 1,08  
VI : 0,96  
Sekundär Antriebsübersetzung 2,81  
secondary Final drive ratio

Höchstgeschwindigkeit [km/h] : 200  
Maximum speed

3.1.3.5 **Bereifung**

**Mounted wheels**

3.1.4 Achse 1 : 90/90-21  
Axle 1

Achse 2 : 150/70-18  
Axle 2

**3.2.1 Fahrzeug #8**  
**Vehicle #8**

- 3.2.1.1 Hersteller : KTM  
Manufacturer
- 3.2.1.2 Typ : KTM R2 Adventure  
Type
- 3.2.1.3 Variante/Version : A / -  
Variant/Version
- 3.2.1.4 Genehmigungsnummer : e1\*168/2013\*00250\*..  
Homologation no.
- 3.2.1.5 Fahrzeugidentifizierungsnummer : VBKTR3P32MM800039  
Vehicle identification number
- 3.2.1.6 Baujahr : 2020  
Year of manufacture
- 3.2.1.7 Kilometerstand : 1745  
Mileage (km)

**3.2.2 Antriebsaggregat**  
**Engine**

- 3.2.2.1 Hersteller : KTM  
Manufacturer
- 3.2.2.2 Typ : 636  
Type
- 3.2.2.3 Nennleistung [kW @ min-1] : 77 @ 8000  
Rated maximum engine power
- 3.2.2.4 Hubraum [cm<sup>3</sup>] : 889  
Cubic capacity

**3.2.3 Kraftübertragung**  
**Transmission**

- 3.2.3.1 Technische Zeichnung des Kraftübertragungssystems : Siehe Fahrzeugtypgenehmigung gemäß 3.1.4  
Tech. Drawing of the power transmission system See WVTA according to 3.1.4
- 3.2.3.2 Art der Kraftübertragung :  mechanisch / mechanic  
Type of power transmission  hydraulisch / hydraulic  
 elektrisch / electric

3.2.3.3 Art des Getriebes :  manuell / manual  
Type of gearbox  automatisch / automatic  
 stufenlos / CVT

3.2.3.4 Getriebeübersetzungen  
Gear ratios

Primär I : 2,84  
primary II : 2,00  
III : 1,55  
IV : 1,27  
V : 1,08  
VI : 0,95  
Sekundär Antriebsübersetzung 2,81  
secondary Final drive ratio

3.2.3.5 Höchstgeschwindigkeit [km/h] : 200  
Maximum speed

### 3.2.4 Bereifung

#### Mounted wheels

Achse 1 : 90/90-21  
Axle 1

Achse 2 : 150/70-18  
Axle 2

- 3.5 Zusammenbau der Abgasanlage** : Siehe Beschreibungsbogen  
*Assembly of the exhaust system* See information document
- 3.6 Messung der Geräuschwerte**  
*Acoustic measurements*
- 3.6.1 Hersteller der Messgeräte : NTI Audio  
*Manufacturer of measurement devices*
- 3.6.2 Type der Messgeräte : XL2 TA  
*Make of measurement devices*
- 3.6.3 Prüfverfahren für Fahrgeräusch :  UNECE-R41.04  
*Testing procedure for driving sound level* UNECE-R41.04  
 VO(EU) 134/2014  
Regulation (EU) 134/2014
- 3.6.4 Prüfverfahren für Standgeräusch : Siehe 3.6.3  
*Testing procedure for stationary vehicle sound level* See 3.6.3
- 3.7 Messung des Abgasgegendrucks**  
*Exhaust back pressure measurements*
- 3.7.1 Hersteller des Messgerätes : WIKA  
*Manufacturer of measurement device*
- 3.7.2 Type des Messgerätes : 909.40.500  
*Make of measurement device*
- 3.7.3 Messmethode : Messung bei Volllast  
*Method of testing* Measurement under full load
- 3.8 Konditionierung der Auspuffschalldämpferanlage** : Straßendauerlauf  
*Conditioning of exhaust gas silencing system* Road permanent run

#### **4. Prüfergebnisse** **Testing results**

- 4.1 Das Messwerte der durchgeführten Prüfungen sind der in Anlage 2 beigefügten Tabelle zu entnehmen.  
*The measured values of the tests carried out shall be taken from the table in Appendix 2.*
- 4.2 Aufgrund eines Vergleiches der Geräuschpegel des beschriebenen Schalldämpfers mit denen des serienmäßigen Schalldämpfers sind beide Schalldämpfer als akustisch gleichwertig zu betrachten.  
*Due to a comparison of the noise level of the exhaust described with those of the standard exhaust, both exhaust systems are considered to be acoustically equivalent.*
- 4.3 Aufgrund dessen sind die Messergebnisse sind für die in Anlage 1 aufgeführten Fahrzeuge und Motoren mit identischen Serienschalldämpfern, die gemäß den nachfolgend genannten Richtlinien geprüft und typgenehmigt wurden, stellvertretend.  
*As a result, the measurement results are representative of the vehicles and engines listed in Appendix 1 with identical series silencers that have been tested and type approved in accordance with the following guidelines.*
- 4.4 Es ist sichergestellt, dass alle in Anlage 1 aufgeführten Fahrzeuge gemäß VO (EU) 134/2014 in der entsprechenden Fassung, bzw. ECE R41.04 typgenehmigt wurden.  
*It is ensured that all vehicles listed in Appendix 1 have been type-approved in accordance with VO (EU) 134/2014 as amended or ECE R41.04*
- 4.5 Die Messergebnisse sind auf den unter Punkt 0.2 genannten Typ inklusiver aller beschriebenen Versionen und Varianten übertragbar.  
*The measurement results are transferable to the type mentioned under point 0.2 including all versions and variants described.*
- 4.6 Die beschriebene technische Einheit darf an den in Anlage 1 aufgeführten Kraftfahrzeugen unter den dort genannten Bedingungen verwendet werden.  
*The described technical unit is suitable for an application at the vehicles named in annex 1 under the conditions specified therein.*
- 4.7 Es wird bestätigt, dass alle im Verwendungsbereich aufgeführten Fahrzeuge über einen serienmäßigen Klappenauspuff verfügen und dass bei Verwendung der Austausch-Schalldämpferanlage die originale Klappensteuerung verwendet wird. Die Klappe entspricht in Bezug auf Form und Abmessung der Serie.  
*It is confirmed that all vehicles specified in the operating range have a standard flap exhaust and that on use of the altered exhaust the original flap control system is used.*

## 5. Anlagen Annexes

Anlage Annex	1	Verwendungsbereich Range of application	2	Seite Page
Anlage Annex	2	Prüfergebnisse Test results	5	Seiten Pages
Anlage Annex	3	Informationsdokument (siehe 0.5) Information documents (acc. to 0.5)	41	Seiten Pages

## 6. Schlussbescheinigung Final statement

Der unter Punkt 0.5. angegebene Beschreibungsbogen und der darin beschriebene Typ entsprechen der oben genannten Prüfspezifikation. Der ungünstigste Fall wurde entsprechend Dokument (QAA-TAA-002\_Auswahlverfahren für worst case) bestimmt.

*The information document as mentioned under No. 0.5 and the type described therein are in compliance with the test specification mentioned above. The worst case was selected in accordance with document (QAA-TAA-002\_Selection process for worst case).*

Dieser Prüfbericht umfasst die Seiten 1 bis 8 und die unter Punkt 5 beschriebenen Anhänge. Der Prüfbericht darf nur vom Auftraggeber und nur in vollem Wortlaut vervielfältigt und weitergegeben werden. Eine auszugsweise Vervielfältigung und Veröffentlichung des Prüfberichtes ist nur nach schriftlicher Genehmigung des Prüflaboratoriums zulässig.

*This test report comprises pages 1 to 8 and the appendices described under point 5. The test report may only be reproduced and passed on by the client and only in full. Reproduction and publication of extracts of the test report is only permitted with the written approval of the testing laboratory.*

Wien / Vienna, 24.04.2023

### TÜV AUSTRIA AUTOMOTIVE GMBH



Benannter Technischer Dienst des Kraftfahrt-Bundesamtes (KBA), Registrier-Nummer KBA-P 00055-00

*Designated Technical Service of Kraftfahrt-Bundesamt (KBA), Germany, Registration number KBA-P 00055-00*



Benannter Technischer Dienst des National Standards Authority of Ireland (NSAI), Technical Service Number 103

*Designated Technical Service by the National Standards Authority of Ireland (NSAI), Technical Service Number 103*

Zeichnungsberechtigter  
Approved signatory



Ing. Andreas PFIEL



Aktenzeichen / File number  
20-TAHO-0148/E2/SCST

Anhang / Annex 1: Verwendungsbereich / Range of application

Hersteller : Remus Innovation GmbH

Manufacturer

Type : HX13

Type

Prüfgegenstand : Austauschschalldämpfer

Subject replacement exhaust

TÜV AUSTRIA AUTOMOTIVE GMBH  
Deutschstraße 10  
A-1230 Wien  
www.tuv.at



23-TAFT-1496

PBV-TAA-003 Rev. 01

Hersteller / Manufacturer		KTM AG								
Fzg. Nr. Vehicle	Handelsbezeichnung Trade name	Fahrzeugtype Vehicle type	Genehmigungs- nummer Approval no.	Fahrzeug- klasse Category	Motortyp / Arbeitsprinzip Engine type / principle		Takt Stroke	Hubraum Capacity [cm <sup>3</sup> ]	Nenn- leistung Engine power [kW]	Anordnung Configuration
#1	KTM 790 Adventure	KTM 790 Adventure	e1*168/2013*00148*..	L3e-A2	635	PI	4-Takt 4 stroke	799	35	siehe Beschreibungs- bogen see information document
#2	KTM 790 Adventure R	KTM 790 Adventure	e1*168/2013*00148*..	L3e-A2	635	PI	4-Takt 4 stroke	799	35	
#3	KTM 890 Adventure	KTM 790 Adventure	e1*168/2013*00148*..	L3e-A2	636	PI	4-Takt 4 stroke	889	35	
#4	KTM 790 Adventure	KTM 790 Adventure	e1*168/2013*00149*..	L3e-A3	635	PI	4-Takt 4 stroke	799	70	
#5	KTM 790 Adventure R	KTM 790 Adventure	e1*168/2013*00149*..	L3e-A3	635	PI	4-Takt 4 stroke	799	70	
#6	KTM 790 Adventure R Rally	KTM 790 Adventure	e1*168/2013*00149*..	L3e-A3	635	PI	4-Takt 4 stroke	799	70	
#7	KTM 890 Adventure	KTM 790 Adventure	e1*168/2013*00149*..	L3e-A3	636	PI	4-Takt 4 stroke	889	70	
#8	KTM 890 Adventure	KTM R2 Adventure	e1*168/2013*00250*..	L3e-A3	636	PI	4-Takt 4 stroke	889	77	
#9	KTM 890 Adventure R	KTM R2 Adventure	e1*168/2013*00250*..	L3e-A3	636	PI	4-Takt 4 stroke	889	77	
#10	KTM 890 Adventure R Rally	KTM R2 Adventure	e1*168/2013*00250*..	L3e-A3	636	PI	4-Takt 4 stroke	889	77	

Aktenzeichen / File number

20-TAHO-0148/E2/SCST

Anhang / Annex 1: Verwendungsbereich / Range of application

Hersteller : Remus Innovation GmbH

Manufacturer

Type : HX13

Type

Prüfgegenstand : Austauschschalldämpfer

Subject : replacement exhaust

TÜV AUSTRIA AUTOMOTIVE GMBH  
Deutschstraße 10  
A-1230 Wien  
www.tuv.at



23-TAFT-1496

PBV-TAA-003 Rev. 01

#11	Husqvarna 901 Norden	Husqvarna 901 HQV N	e1*168/2013*00295*..	L3e-A3	637	PI	4-Takt 4 stroke	889	77	siehe Beschreibungs- bogen see information document
#12	KTM 890 SMT	KTM R2 Adventure	e1*168/2013*00250*..	L3e-A3	636	PI	4-Takt 4 stroke	889	77	
#13	KTM 790 Adventure	KTM CV1 Adventure	e1*168/2013*00337*..	L3e-A2	646	PI	4-Takt 4 stroke	799	35	
#14	KTM 790 Adventure	KTM CV1 Adventure	e1*168/2013*00328*..	L3e-A3	646	PI	4-Takt 4 stroke	799	70	
#15	Husqvarna 901 Norden Expedition	Husqvarna 901 HQV N	e1*168/2013*00295*..	L3e-A3	637	PI	4-Takt 4 stroke	889	77	

Der Verwendungsbereich gilt für Abgaseinstufung EURO 4 und für EURO 5.

The range of application is valid for vehicles with emission class EURO 4 and EURO 5.

Anhang / Annex 2: Prüfergebnisse / Test results

Hersteller : Remus Innovation GmbH

Manufacturer

Type : HX13

Type

Prüfgegenstand : Austauschschalldämpfer

Subject replacement exhaust

Fahrzeug-Nr. / Vehicle-No.	#5
FIN / VIN	VBKTR3409KM750618
Variante / Version / Variant / Version	B / -
Power to Mass Ratio index (PMR) [-]	245,61
$l_{ref}$ [m]	2,26
Testmasse / test mass (mt) [kg]	285
$a_{urban\ ref}$ [m/s <sup>2</sup> ]	1,87
$a_{wot\ ref}$ [m/s <sup>2</sup> ]	3,80
Teillastfaktor / Partial power factor kp [-]	0,508

Umgebungsbedingungen / meteorological data	
Temperatur / Temperature	28,6 [°C]
Luftdruck / Air pressure	972 [hPa]
Windgeschwindigkeit / Wind speed	1,2 [m/s]
Luftfeuchtigkeit / Humidity	46,5 [%]
Umgebungsgeräusch / Ambient noise	52,2 [dB(A)]

Messergebnisse im Detail - Fahrgeräusch / measurement results in detail – moving sound level

$L_{wot, 3^{rd}\ gear\ V_{pp}=50km/h}$	vAA (km/h)	vPP (km/h)	vBB (km/h)	$A_{wot\ AA-BB}$ (m/s <sup>2</sup> )	$L_{wot\ left}$ (dB(A))	$L_{wot\ right}$ (dB(A))	$L_{wot\ Max}$ [dB(A)]
1.Test	37,2	50,1	63,1	4,50	80,1	82,0	
2.Test	36,2	49,2	62,7	4,54	80,2	80,5	
3.Test	36,5	50,1	62,8	4,53	80,4	81,7	
Average / Mittelwert	36,6	49,8	62,9	4,52	80,2	81,4	<b>81,4</b>

$L_{crs, 3^{rd}\ gear\ 50km/h}$	vAA (km/h)	vPP (km/h)	vBB (km/h)	$L_{crs\ left}$ (dB(A))	$L_{crs\ right}$ (dB(A))	$L_{crs\ Max}$ [dB(A)]
1.Test	49,2	49,9	50,9	73,8	74,2	
2.Test	50,4	49,4	50,2	73,5	74,0	
3.Test	50,1	49,3	49,7	73,0	74,3	
Average / Mittelwert	49,9	49,5	50,3	73,4	74,2	<b>74,2</b>

Anhang / Annex 2: Prüfergebnisse / Test results

Hersteller : Remus Innovation GmbH  
 Manufacturer  
 Type : HX13  
 Type  
 Prüfgegenstand : Austauschschalldämpfer  
 Subject replacement exhaust

L <sub>wot</sub> , 4th gear V <sub>pp</sub> =50km/h	vAA (km/h)	vPP (km/h)	vBB (km/h)	A <sub>wot</sub> AA-BB (m/s <sup>2</sup> )	L <sub>wot</sub> left (dB(A))	L <sub>wot</sub> right (dB(A))	L <sub>wot</sub> Max [dB(A)]
1.Test	40,5	49,0	59,0	3,19	79,2	79,7	
2.Test	40,9	50,1	60,1	3,36	79,0	79,8	
3.Test	41,1	49,2	58,9	3,09	78,9	79,7	
Average / Mittelwert	40,8	49,4	59,3	3,21	79,0	79,7	<b>79,7</b>

L <sub>crs</sub> , 4th gear 50km/h	vAA (km/h)	vPP (km/h)	vBB (km/h)	L <sub>crs</sub> left (dB(A))	L <sub>crs</sub> right (dB(A))	L <sub>crs</sub> Max [dB(A)]
1.Test	49,4	49,4	50,4	72,6	73,4	
2.Test	50,3	49,7	49,8	72,6	72,9	
3.Test	49,6	50,4	50,3	72,3	73,3	
Average / Mittelwert	49,8	49,8	50,2	72,5	73,2	<b>73,2</b>

L <sub>urban</sub>		L <sub>urban</sub> [dB(A)]
Schalldruckpegel L <sub>urban</sub> Sound pressure level L <sub>urban</sub>	L <sub>urban</sub> = L <sub>wot</sub> – k <sub>p</sub> * (L <sub>wot</sub> – L <sub>crs</sub> )	<b>77,0</b>

Messergebnisse im Detail – Standgeräusch / measurement results in detail – stationary sound level

Standgeräusch Stationary Sound Level	LHS / links [dB(A)]	RHS / rechts [dB(A)]	Prüfdrehzahl [min <sup>-1</sup> ] Target Engine Speed [min-1]
1.Test	--	90,3	<b>4250</b>
2.Test	--	90,0	
3.Test	--	89,9	
Prüfergebnis Test result	--	<b>90</b>	

Anhang / Annex 2: Prüfergebnisse / Test results

Hersteller : Remus Innovation GmbH  
 Manufacturer  
 Type : HX13  
 Type  
 Prüfgegenstand : Austauschschalldämpfer  
 Subject replacement exhaust

Fahrzeug-Nr. / Vehicle-No.	#8
FIN / VIN	VBKTR3P32MM800039
Variante / Version / Variant / Version	A / -
Power to Mass Ratio index (PMR) [-]	265,52
$l_{ref}$ [m]	2,1
Testmasse / test mass (mt) [kg]	290
$a_{urban\ ref}$ [m/s <sup>2</sup> ]	1,91
$a_{wot\ ref}$ [m/s <sup>2</sup> ]	3,91
Teillastfaktor / Partial power factor kp [-]	0,485

Umgebungsbedingungen / meteorological data	
Temperatur / Temperature	29,6 [°C]
Luftdruck / Air pressure	972 [hPa]
Windgeschwindigkeit / Wind speed	1,8 [m/s]
Luftfeuchtigkeit / Humidity	42,8 [%]
Umgebungsgeräusch / Ambient noise	51,6 [dB(A)]

Messergebnisse im Detail - Fahrgeräusch / measurement results in detail – moving sound level

$L_{wot, 4th\ gear\ V_{pp}=50km/h}$	vAA (km/h)	vPP (km/h)	vBB (km/h)	$A_{wot\ AA-BB}$ (m/s <sup>2</sup> )	$L_{wot\ left}$ (dB(A))	$L_{wot\ right}$ (dB(A))	$L_{wot\ Max}$ [dB(A)]
1.Test	40,1	50,2	61,6	3,82	81,0	81,6	
2.Test	40,6	50,2	62,0	3,83	81,0	81,6	
3.Test	40,7	50,5	62,6	3,95	81,6	82,0	
Average / Mittelwert	40,5	50,3	62,1	3,87	81,2	81,7	<b>81,7</b>

$L_{crs, 4th\ gear\ 50km/h}$	vAA (km/h)	vPP (km/h)	vBB (km/h)	$L_{crs\ left}$ (dB(A))	$L_{crs\ right}$ (dB(A))	$L_{crs\ Max}$ [dB(A)]
1.Test	50,2	50,3	50,4	72,1	72,6	
2.Test	49,8	50,5	50,2	71,5	72,0	
3.Test	49,9	50,1	49,9	71,2	71,9	
Average / Mittelwert	50,0	50,3	50,2	71,6	72,2	<b>72,2</b>

$L_{urban}$		$L_{urban}$ [dB(A)]
Schalldruckpegel $L_{urban}$ Sound pressure level $L_{urban}$	$L_{urban} = L_{wot} - kp * (L_{wot} - L_{crs})$	<b>76,9</b>

Aktenzeichen / File number  
20-TAHO-0148/E2/SCST

Anhang / Annex 2: Prüfergebnisse / Test results  
Hersteller : Remus Innovation GmbH  
Manufacturer  
Type : HX13  
Type  
Prüfgegenstand : Austauschschalldämpfer  
Subject replacement exhaust

TÜV AUSTRIA AUTOMOTIVE GMBH  
Deutschstraße 10  
A-1230 Wien  
www.tuv.at



23-TAFT-1496

PBV-TAA-003 Rev. 01

### Messergebnisse im Detail – Standgeräusch / measurement results in detail – stationary sound level

Standgeräusch <i>Stationary Sound Level</i>	LHS / links [dB(A)]	RHS / rechts [dB(A)]	Prüfdrehzahl [min <sup>-1</sup> ] <i>Target Engine Speed [min-1]</i>
1.Test	--	87,8	4000
2.Test	--	87,5	
3.Test	--	87,4	
Prüfergebnis <i>Test result</i>	--	88	

Anhang / Annex 2: Prüfergebnisse / Test results

Hersteller : Remus Innovation GmbH  
 Manufacturer  
 Type : HX13  
 Type  
 Prüfgegenstand : Austauschschalldämpfer  
 Subject replacement exhaust

Übersicht Messergebnisse / Overview test data

Fahrzeug Nr. Vehicle No.	Geräuschwerte Sound level values							
	Fahrgeräusch LUrban Moving vehicle					Standgeräusch Stationary vehicle		
	Gang Gear	WVTA [dB(A)]	OEM <sub>gemessen</sub> OEM <sub>measured</sub> [dB(A)]	Austausch- schalldämpfer Replacement exhaust [dB(A)]	Grenzwert <sup>1)</sup> Limit <sup>1)</sup> [dB(A)]	WVTA [dB(A)]	OEM <sub>gemessen</sub> OEM <sub>measured</sub> [dB(A)@min <sup>-1</sup> ]	Austausch- schalldämpfer Replacement exhaust [dB(A)@min <sup>-1</sup> ]
#5	3, 4	77	76,9	77,0	77	90	89/4250	90/4250
#8	4	77	76,8	76,9	77	88	88/4000	88/4000

<sup>1)</sup> Grenzwert lt. Richtlinie od. Verordnung der Fahrzeugtypgenehmigung

<sup>\*)</sup> limit value of directive which was valid when vehicle type approval was issued

Übersicht ASEP / Overview ASEP

Fahrzeug Nr.: #5 Vehicle No.:		nAA' (min <sup>-1</sup> )	VAA' (km/h)	nPP' (min <sup>-1</sup> )	VPP' (km/h)	nBB' (min <sup>-1</sup> )	VBB' (km/h)	ASEP noise level [dB(A)]	ASEP noise limit [dB(A)]
1.st ref.	3 <sup>th</sup> gear	2717	36,5	3568	50,2	4444	63,2	82,3	84,7
2nd ref.	3 <sup>th</sup> gear	3302	44,9	4049	57,4	4837	68,8	83,5	86,1
1.add	4 <sup>th</sup> gear	2344	39,7	2796	48,3	3340	57,9	80,8	83,8
2nd add.	4 <sup>th</sup> gear	2930	49,7	3379	58,6	3886	67,6	81,8	84,3

Fahrzeug Nr.: #8 Vehicle No.:		nAA' (min <sup>-1</sup> )	VAA' (km/h)	nPP' (min <sup>-1</sup> )	VPP' (km/h)	nBB' (min <sup>-1</sup> )	VBB' (km/h)	ASEP noise level [dB(A)]	ASEP noise limit [dB(A)]
1.st ref.	4 <sup>th</sup> gear	2333	40,3	2936	50,4	3552	61,6	81,7	84,7
2nd ref.	3 <sup>th</sup> gear	3812	45,2	4108	58,9	5015	71,6	84,0	90,5
1.add	4 <sup>th</sup> gear	2953	50,0	3463	60,0	4035	70,4	82,9	87,3
2nd add.	3 <sup>th</sup> gear	3100	35,5	3524	49,6	4548	64,6	83,1	87,6



# Beschreibungsmappe Information folder

<b>Beschreibungsmappe Nr. HX13/01</b> für die EU-Typgenehmigung einer lärmmindernden Einrichtung als selbständige technische Einheit (STE) gemäß Artikel 27 der Verordnung (EU) Nr. 168/2013	<b>Datum / date</b> 06.10.2020 geändert / <i>modified</i> 07.02.2023
<b>Information folder No. HX13/01</b> relating to type-approval of a noise-abatement device as a separate technical unit (STU) according to article 27 of the Regulation (EU) no. 168/2013	<b>Blatt 1 von 1 /</b> <b>Sheet 1 of 1</b>

## Inhaltsverzeichnis / table of contents:

	Zeichnungs-Nr. Drawing – no.	Datum date
<b>Beschreibungsbogen / Information document HX13/02</b>		<b>07.02.2023</b>
Zeichnung Schalldämpfer / <i>Drawing of silencer</i>	20ESD10061.1	06.10.2020
Stückliste / <i>Parts list</i>	20ESD10061.2	06.10.2020
Zeichnung VBR / <i>Drawing of connecting pipe</i>	20ESD10061.3	06.10.2020
Zeichnung Gesamtanlage / <i>Drawing noise reduction system</i>	20ESD10061.4	06.10.2020
Montageanleitung / <i>Mounting instructions</i>	KTM 790 / 890 Adventure / <b>Husqvarna Norden 901</b>	

**Ort / place:** Voitsberg

**Datum / date:** 07.02.2023

**Unterschrift / signature**

**Name und Stellung im Unternehmen /**

**Name and position in the company:**

Stephan Zöchling, CEO

<b>Beschreibungsbogen Nr. HX13/02</b> <b>für die EU-Typgenehmigung eines Abgassystems</b> <b>(lärmmindernden Einrichtung) als STE</b> <b>gemäß Artikel 27 der Verordnung (EU) Nr. 168/2013</b>	<b>Datum / date</b> <b>06.10.2020</b> <b>geändert / modified</b> <b>07.02.2023</b>
<b>Information document No. HX13/02</b> <b>relating to EU type-approval of an exhaust (noise-abatement device) as a STU</b> <b>according to article 27 of the Regulation (EU) no. 168/2013</b>	<b>Blatt 1 von 7 /</b> <b>Sheet 1 of 7</b>

**B Allgemeine Angaben zu Systemen, Bauteilen und selbständigen technischen Einheiten**  
**General information concerning systems, components or separate technical units**

- 0.7 Fabrikmarke(n) (Firmenname(n) des Herstellers) : REMUS  
*Make(s) (trade name(s) of manufacturer)*
- 0.8 Typ : HX13  
*Type*
- 0.8.1 Handelsname(n) (sofern vorhanden) : N/A  
*Commercial name(s) (if available)*
- 0.8.2 Typgenehmigungsnummer(n), sofern vorhanden : e24\*134/2014\*2018/295G\*00307\*01  
*Type-approval number(s) (if available)*
- 0.8.3 Typgenehmigung(en) erteilt am (Datum, falls bekannt) : 11.01.2021  
*Type-approval(s) issued on (date, if available)*
- 0.9 Firmenname und Anschrift des Herstellers : Remus Innovation GmbH  
*Company name and address of manufacturer*  
Ruhmannstraße 11  
A-8570 Voitsberg
- 0.9.1 Name(n) und Anschrift(en) der Fertigungsstätte(n) : Remus Innovation Forschungs- und  
*Name(s) and address(es) of assembly plants*  
Abgasanlagen Produktions GmbH  
Dr. Niederdorferstraße 25  
A-8572 Bärnbach  
  
Remus Innovation GmbH  
Ruhmannstraße 11  
A-8570 Voitsberg
- 0.9.2 Gegebenenfalls Name und Anschrift des Bevollmächtigten des : N/A  
Herstellers  
*Name and address of manufacturer's authorised representative, if any*
- 0.10 **Fahrzeug(e), für welche(s) das System/die selbständige technische Einheit bestimmt ist**  
**Vehicle(s) for which the system/separate technical unit is intended for**
- 0.10.1 Typ : Siehe Tabelle 1 / see table 1  
*Type*
- 0.10.2 Variante : Siehe Tabelle 1 / see table 1  
*Variant*
- 0.10.3 Version : Siehe Tabelle 1 / see table 1  
*Version*
- 0.10.4 Handelsname(n) (sofern vorhanden) : Siehe Tabelle 1 / see table 1  
*Commercial name(s) (if available)*
- 0.10.5 Klasse, Unterklasse und Unter-Unterklasse des Fahrzeugs : Siehe Tabelle 1 / see table 1  
*Category, subcategory and sub-subcategory of vehicle*

**C Allgemeine Angaben zur Übereinstimmung der Produktion und zum Zugang zu Reparatur- und**  
**Wartungsinformationen**  
**General information regarding conformity of production and access to repair and maintenance**  
**information**

**1. ALLGEMEINE BAUMERKMALE**  
**GENERAL CONSTRUCTION CHARACTERISTICS**

- 1.8 Leistung der Antriebseinheit  
*Propulsion unit performance*
- 1.8.1 Angegebene Höchstgeschwindigkeit des Fahrzeugs : Siehe Tabelle 2 / see table 2  
*Declared maximum vehicle speed*
- 1.8.2 Bauartbedingte Höchstgeschwindigkeit des Fahrzeugs und Gang, : siehe Fahrzeugtypengenehmigung  
in dem diese erreicht wird

<b>Beschreibungsbogen Nr. HX13/02</b> <b>für die EU-Typgenehmigung eines Abgassystems</b> <b>(lärmmindernden Einrichtung) als STE</b> <b>gemäß Artikel 27 der Verordnung (EU) Nr. 168/2013</b>	<b>Datum / date</b> <b>06.10.2020</b> <b>geändert / modified</b> <b>07.02.2023</b>
<b>Information document No. HX13/02</b> <b>relating to EU type-approval of an exhaust (noise-abatement device) as a STU</b> <b>according to article 27 of the Regulation (EU) no. 168/2013</b>	
	<b>Blatt 2 von 7 /</b> <b>Sheet 2 of 7</b>

	<i>Maximum design vehicle speed and gear in which it is reached</i>	see WVTA
1.8.3	Maximale Nutzleistung des Verbrennungsmotors bei Luft/Kraftstoff-Verhältnis <i>Maximum net power combustion engine at AF-ratio</i>	: Siehe Tabelle 2 L/K-Verhältnis N/A see table 2 A/F-ratio N/A
1.8.4	Maximales Nutzdrehmoment des Verbrennungsmotors at AF-ratio bei Luft/Kraftstoff-Verhältnis <i>Maximum net torque combustion engine</i>	: Siehe Tabelle 2 L/K-Verhältnis N/A see table 2 A/F-ratio N/A
1.8.5	Maximale Nenndauerleistung des Elektromotors (Leistung über 15/ 30 Minuten ) <i>Maximum continuous-rated power electric motor (15/30 minutes power)</i>	: N/A
1.8.6	Maximales Nenn-Dauerdrehmoment des Elektromotors <i>Maximum continuous-rated torque electric motor</i>	: N/A
1.8.7	Maximale Dauer-Gesamtleistung des Antriebs (der Antriebe) <i>Maximum continuous total power for propulsion(s)</i>	: N/A
1.8.8	Maximales Dauer-Gesamtdrehmoment des Antriebs (der Antriebe) <i>Maximum continuous total torque for propulsion(s)</i>	: N/A
1.8.9	Maximale Spitzenleistung des Antriebs (der Antriebe) <i>Maximum peak power for propulsion(s)</i>	: N/A
<b>4.0</b>	<b>Allgemeine Angaben zu Umweltverträglichkeit und Antriebsleistung</b> <b>General information on environmental and propulsion performance</b>	
4.0.6	Geräuschpegel <i>Sound level</i>	
4.0.6.1	Grenzwert für $L_{Urban}$ <i>Limit value for <math>L_{Urban}</math></i>	[dB(A)] : 77
<b>4.4</b>	<b>Zusätzliche Angaben zu Umweltverträglichkeit und Antriebsleistung</b> <b>Additional information on environmental and propulsion unit performance</b>	
4.4.4	Dieser Beschreibungsbogen ist in Bezug auf die lärmmindernden Einrichtungen durch den geltenden Beschreibungsbogen gemäß der UNECE-Regelung Nr. 92 zu ergänzen. <i>Applicable information document set out in respectively UN Regulation No 92 shall supplement this information document with regards to the noise-abatement devices installed on the vehicle.</i>	
	Kraftrad <i>Motorcycle</i>	
	Marke (Handelsname des Herstellers) <i>Make (Trade name of manufacturer)</i>	: Siehe Tabelle 3 / see table 3
	EU-Typengenehmigungsnummer	: Siehe Tabelle 3 / see table 3
	Ab Baujahr <i>From model year</i>	: Siehe Tabelle 3 / see table 3
	Verbrennungsmotor <i>Combustion engine</i>	
	Baumusterbezeichnung gemäß Kennzeichnung am Motor oder sonstige Identifizierungsmerkmale <i>Engine code (as marked on the engine or other means of identification)</i>	: Siehe Tabelle 3 / see table 3
	Maximale Nennleistung <i>rated maximum net power</i>	[kW/min <sup>-1</sup> ] : Siehe Tabelle 2 / see table 2

<b>Beschreibungsbogen Nr. HX13/02</b> für die EU-Typgenehmigung eines Abgassystems (lärmmindernden Einrichtung) als STE gemäß Artikel 27 der Verordnung (EU) Nr. 168/2013	Datum / <i>date</i> 06.10.2020 geändert / <i>modified</i> 07.02.2023
<b>Information document No. HX13/02</b> <i>relating to EU type-approval of an exhaust (noise-abatement device) as a STU according to article 27 of the Regulation (EU) no. 168/2013</i>	Blatt 3 von 7 / Sheet 3 of 7

Arbeitsweise <i>Working principle</i>	: Fremdzündung / <del>Selbstzündung</del> <i>positive ignition / <del>compressed</del></i> <i>ignition</i>
Arbeitsweise <i>cycle</i>	: Viertakt <i>four stroke</i>
Hubvolumen <i>Enginge capacity</i>	[cm <sup>3</sup> ] : Siehe Tabelle 3 / <i>see table 3</i>
Kraftübertragung <i>Drive-train</i>	Kette <i>chain</i>
Getriebe <i>Transmission</i>	: Manuell <i>manual</i>
Anzahl der Gänge <i>Number of gears</i>	: 6
Übersetzungsverhältnisse <i>Gear ratios</i>	I : Siehe Tabelle 4 / <i>see table 4</i> II : Siehe Tabelle 4 / <i>see table 4</i> III : Siehe Tabelle 4 / <i>see table 4</i> IV : Siehe Tabelle 4 / <i>see table 4</i> V : Siehe Tabelle 4 / <i>see table 4</i> VI : Siehe Tabelle 4 / <i>see table 4</i> VII : -
Antriebsübersetzung <i>Final drive</i>	: Siehe Tabelle 4 / <i>see table 4</i>

<b>Beschreibungsbogen Nr. HX13/02</b> für die EU-Typgenehmigung eines Abgassystems (lärmmindernden Einrichtung) als STE gemäß Artikel 27 der Verordnung (EU) Nr. 168/2013	Datum / date <b>06.10.2020</b> geändert / modified <b>07.02.2023</b>
<b>Information document No. HX13/02</b> relating to EU type-approval of an exhaust (noise-abatement device) as a STU according to article 27 of the Regulation (EU) no. 168/2013	Blatt 4 von 7 / Sheet 4 of 7

Tabelle 1 :

table 1 :

Fzg. Nr. Vehicle	Marke	Typ Type	Variante Variant	Version Version	Handelsname(n) Commercial name(s)	Klasse Category
1	KTM	KTM 790 Adventure	A	-	KTM 790 Adventure	L3e-A2
2	KTM	KTM 790 Adventure	B	-	KTM 790 Adventure R	L3e-A2
3	KTM	KTM 790 Adventure	A	-	KTM 790 Adventure	L3e-A3
4	KTM	KTM 790 Adventure	B	-	KTM 790 Adventure R	L3e-A3
5	KTM	KTM 790 Adventure	A	-	KTM 790 Adventure	L3e-A3
6	KTM	KTM 790 Adventure	B	-	KTM 790 Adventure R	L3e-A3
7	KTM	KTM 790 Adventure	C	-	KTM 790 Adventure R Rally	L3e-A3
8	KTM	KTM 790 Adventure	A	-	KTM 790 Adventure	L3e-A2
9	KTM	KTM 790 Adventure	B	-	KTM 790 Adventure R	L3e-A2
10	KTM	KTM 790 Adventure	C	-	KTM 890 Adventure	L3e-A2
11	KTM	KTM 790 Adventure	A	-	KTM 790 Adventure	L3e-A3
12	KTM	KTM 790 Adventure	B	-	KTM 790 Adventure R	L3e-A3
13	KTM	KTM 790 Adventure	C	-	KTM 790 Adventure R Rally	L3e-A3
14	KTM	KTM 790 Adventure	D	-	KTM 890 Adventure	L3e-A3
15	KTM	KTM R2 Adventure	A	-	KTM 890 Adventure	L3e-A3
16	KTM	KTM R2 Adventure	B	-	KTM 890 Adventure R	L3e-A3
17	KTM	KTM R2 Adventure	C	-	KTM 890 Adventure R Rally	L3e-A3
18	Husqvarna	HQV N	A	-	Husqvarna 901 Norden	L3e-A3
19	<b>KTM</b>	<b>KTM R2 Adventure</b>	<b>A</b>	-	<b>KTM 890 Adventure</b>	<b>L3e-A3</b>
20	<b>KTM</b>	<b>KTM R2 Adventure</b>	<b>B</b>	-	<b>KTM 890 Adventure R</b>	<b>L3e-A3</b>
21	<b>KTM</b>	<b>KTM R2 Adventure</b>	<b>C</b>	-	<b>KTM 890 Adventure R Rally</b>	<b>L3e-A3</b>
22	<b>KTM</b>	<b>KTM R2 Adventure</b>	<b>D</b>	-	<b>KTM 890 SM T</b>	<b>L3e-A3</b>
23	<b>KTM</b>	<b>KTM CV1 Adventure</b>	<b>A</b>	-	<b>KTM 790 Adventure</b>	<b>L3e-A2</b>
24	<b>KTM</b>	<b>KTM CV1 Adventure</b>	<b>A</b>	-	<b>KTM 790 Adventure</b>	<b>L3e-A3</b>
25	<b>Husqvarna</b>	<b>HQV N</b>	<b>A</b>	-	<b>Husqvarna 901 Norden</b>	<b>L3e-A3</b>
26	<b>Husqvarna</b>	<b>HQV N</b>	<b>B</b>	-	<b>Husqvarna 901 Norden Expedition</b>	<b>L3e-A3</b>

<b>Beschreibungsbogen Nr. HX13/02</b> für die EU-Typgenehmigung eines Abgassystems (lärmmindernden Einrichtung) als STE gemäß Artikel 27 der Verordnung (EU) Nr. 168/2013	Datum / date <b>06.10.2020</b> geändert / modified <b>07.02.2023</b>
<b>Information document No. HX13/02</b> relating to EU type-approval of an exhaust (noise-abatement device) as a STU according to article 27 of the Regulation (EU) no. 168/2013	Blatt 5 von 7 / Sheet 5 of 7

Tabelle 2 :  
table 2 :

Fzg. Nr. Vehicle	Höchstgeschwindigkeit Maximum vehicle speed [km/h]	Maximale Nutzleistung Maximum net power [kW / min-1]	Maximales Nutzdrehmoment Maximum net torque [Nm / min-1]	Umweltanforderungsstufe Environmental step
1	165	35 / 4750	76 / 4000	Euro 4
2	165	35 / 4750	76 / 4000	Euro 4
3	200	70 / 8250	87 / 6500	Euro 4
4	200	70 / 8250	87 / 6500	Euro 4
5	200	70 / 8250	87 / 6500	Euro 4
6	200	70 / 8250	87 / 6500	Euro 4
7	200	70 / 8250	87 / 6500	Euro 4
8	165	35 / 4750	76 / 4000	Euro 4
9	165	35 / 4750	76 / 4000	Euro 4
10	165	35 / 4250	76 / 4000	Euro 5
11	200	70 / 8250	87 / 6500	Euro 4
12	200	70 / 8250	87 / 6500	Euro 4
13	200	70 / 8250	87 / 6500	Euro 4
14	200	70 / 8000	91 / 6750	Euro 5
15	200	77 / 8000	100 / 6500	Euro 5
16	200	77 / 8000	100 / 6500	Euro 5
17	200	77 / 8000	100 / 6500	Euro 5
18	200	77 / 8000	100 / 6500	Euro 5
<b>19</b>	<b>200</b>	<b>77 / 8000</b>	<b>100 / 6500</b>	<b>Euro 5</b>
<b>20</b>	<b>200</b>	<b>77 / 8000</b>	<b>100 / 6500</b>	<b>Euro 5</b>
<b>21</b>	<b>200</b>	<b>77 / 8000</b>	<b>100 / 6500</b>	<b>Euro 5</b>
<b>22</b>	<b>200</b>	<b>77 / 8000</b>	<b>100 / 6500</b>	<b>Euro 5</b>
<b>23</b>	<b>165</b>	<b>35 / 4500</b>	<b>74 / 4500</b>	<b>Euro 5</b>
<b>24</b>	<b>192</b>	<b>70 / 8250</b>	<b>87 / 6500</b>	<b>Euro 5</b>
<b>25</b>	<b>200</b>	<b>77 / 8000</b>	<b>100 / 6500</b>	<b>Euro 5</b>
<b>26</b>	<b>200</b>	<b>77 / 8000</b>	<b>100 / 6500</b>	<b>Euro 5</b>

<b>Beschreibungsbogen Nr. HX13/02</b> <b>für die EU-Typgenehmigung eines Abgassystems</b> <b>(lärmmindernden Einrichtung) als STE</b> <b>gemäß Artikel 27 der Verordnung (EU) Nr. 168/2013</b>	<b>Datum / date</b> <b>06.10.2020</b> <b>geändert / modified</b> <b>07.02.2023</b>
<b>Information document No. HX13/02</b> <b>relating to EU type-approval of an exhaust (noise-abatement device) as a STU</b> <b>according to article 27 of the Regulation (EU) no. 168/2013</b>	
	<b>Blatt 6 von 7 /</b> <b>Sheet 6 of 7</b>

Tabelle 3 :  
table 3 :

Fzg. Nr. Vehicle	Motorhersteller Engine manufacturer	Typenehmigungsnummer type approval number	Baumusterbezeichnung Motor Engine code	Hubvolumen Engine capacity [cm <sup>3</sup> ]	Baujahr model year
1	KTM	e1*168/2013*00148*00	635	799	2019
2	KTM	e1*168/2013*00148*00	635	799	2019
3	KTM	e1*168/2013*00149*00	635	799	2019
4	KTM	e1*168/2013*00149*00	635	799	2019
5	KTM	e1*168/2013*00149*01, Korr. 01	635	799	2020
6	KTM	e1*168/2013*00149*01, Korr. 01	635	799	2020
7	KTM	e1*168/2013*00149*01, Korr. 01	635	799	2020
8	KTM	e1*168/2013*00148*01	635	799	2020
9	KTM	e1*168/2013*00148*01	635	799	2020
10	KTM	e1*168/2013*00148*01	636	889	2021
11	KTM	e1*168/2013*00149*02	635	799	2020
12	KTM	e1*168/2013*00149*02	635	799	2020
13	KTM	e1*168/2013*00149*02	635	799	2020
14	KTM	e1*168/2013*00149*02	636	889	2021
15	KTM	e1*168/2013*00250*00	636	889	2021
16	KTM	e1*168/2013*00250*00	636	889	2021
17	KTM	e1*168/2013*00250*00	636	889	2021
18	KTM	e1*168/2013*00295*00	637	889	2021
<b>19</b>	<b>KTM</b>	<b>e1*168/2013*00250*01</b>	<b>636</b>	<b>889</b>	<b>2023</b>
<b>20</b>	<b>KTM</b>	<b>e1*168/2013*00250*01</b>	<b>636</b>	<b>889</b>	<b>2023</b>
<b>21</b>	<b>KTM</b>	<b>e1*168/2013*00250*01</b>	<b>636</b>	<b>889</b>	<b>2023</b>
<b>22</b>	<b>KTM</b>	<b>e1*168/2013*00250*02</b>	<b>636</b>	<b>889</b>	<b>2023</b>
<b>23</b>	<b>KTM</b>	<b>e1*168/2013*00337*00</b>	<b>646</b>	<b>799</b>	<b>2023</b>
<b>24</b>	<b>KTM</b>	<b>e1*168/2013*00328*00</b>	<b>646</b>	<b>799</b>	<b>2023</b>
<b>25</b>	<b>KTM</b>	<b>e1*168/2013*00295*01</b>	<b>637</b>	<b>889</b>	<b>2023</b>
<b>26</b>	<b>KTM</b>	<b>e1*168/2013*00295*01</b>	<b>637</b>	<b>889</b>	<b>2023</b>

<b>Beschreibungsbogen Nr. HX13/02</b> für die EU-Typgenehmigung eines Abgassystems (lärm mindernden Einrichtung) als STE gemäß Artikel 27 der Verordnung (EU) Nr. 168/2013	Datum / date 06.10.2020 geändert / modified 07.02.2023
<b>Information document No. HX13/02</b> relating to EU type-approval of an exhaust (noise-abatement device) as a STU according to article 27 of the Regulation (EU) no. 168/2013	
	Blatt 7 von 7 / Sheet 7 of 7

Tabelle 4 :  
table 4 :

Fzg. Nr. Vehicle	Übersetzungsverhältnisse Gear ratio						Antriebsübersetzung final drive
	I	II	III	IV	V	VI	
1	2,84	2,00	1,55	1,27	1,08	0,95	2,81
2	2,84	2,00	1,55	1,27	1,08	0,95	2,81
3	2,84	2,00	1,55	1,27	1,08	0,95	2,81
4	2,84	2,00	1,55	1,27	1,08	0,95	2,81
5	2,84	2,00	1,55	1,27	1,08	0,95	2,81
6	2,84	2,00	1,55	1,27	1,08	0,95	2,81
7	2,84	2,00	1,55	1,27	1,08	0,95	2,81
8	2,84	2,00	1,55	1,27	1,08	0,95	2,81
9	2,84	2,00	1,55	1,27	1,08	0,95	2,81
10	2,84	2,00	1,55	1,27	1,08	0,95	2,81
11	2,84	2,00	1,55	1,27	1,08	0,95	2,81
12	2,84	2,00	1,55	1,27	1,08	0,95	2,81
13	2,84	2,00	1,55	1,27	1,08	0,95	2,81
14	2,84	2,00	1,55	1,27	1,08	0,95	2,81
15	2,84	2,00	1,55	1,27	1,08	0,95	2,81
16	2,84	2,00	1,55	1,27	1,08	0,95	2,81
17	2,84	2,00	1,55	1,27	1,08	0,95	2,81
18	2,84	2,00	1,55	1,27	1,08	0,95	2,81
<b>19</b>	<b>2,84</b>	<b>2,00</b>	<b>1,55</b>	<b>1,27</b>	<b>1,08</b>	<b>0,95</b>	<b>2,81</b>
<b>20</b>	<b>2,84</b>	<b>2,00</b>	<b>1,55</b>	<b>1,27</b>	<b>1,08</b>	<b>0,95</b>	<b>2,81</b>
<b>21</b>	<b>2,84</b>	<b>2,00</b>	<b>1,55</b>	<b>1,27</b>	<b>1,08</b>	<b>0,95</b>	<b>2,81</b>
<b>22</b>	<b>2,84</b>	<b>2,00</b>	<b>1,55</b>	<b>1,27</b>	<b>1,08</b>	<b>0,95</b>	<b>2,68</b>
<b>23</b>	<b>2,84</b>	<b>2,00</b>	<b>1,55</b>	<b>1,27</b>	<b>1,08</b>	<b>0,95</b>	<b>2,81</b>
<b>24</b>	<b>2,84</b>	<b>2,00</b>	<b>1,55</b>	<b>1,27</b>	<b>1,08</b>	<b>0,95</b>	<b>2,81</b>
<b>25</b>	<b>2,84</b>	<b>2,00</b>	<b>1,55</b>	<b>1,27</b>	<b>1,08</b>	<b>0,95</b>	<b>2,81</b>
<b>26</b>	<b>2,84</b>	<b>2,00</b>	<b>1,55</b>	<b>1,27</b>	<b>1,08</b>	<b>0,95</b>	<b>2,81</b>

Schnitt CC:  
Section CC:

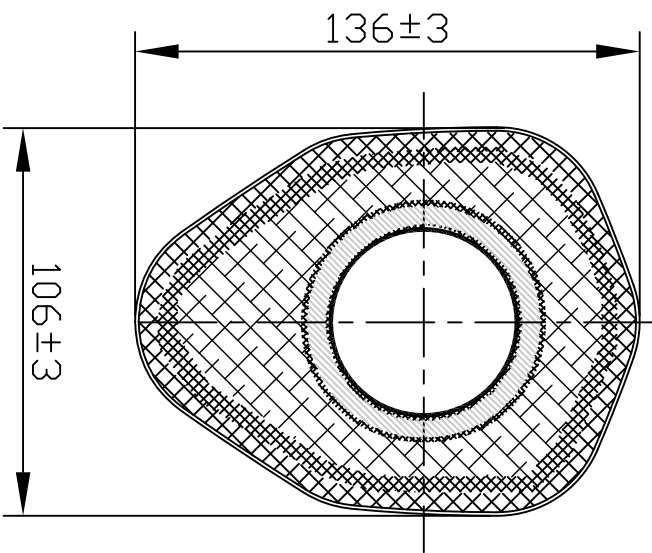

Ansicht A:  
View A:

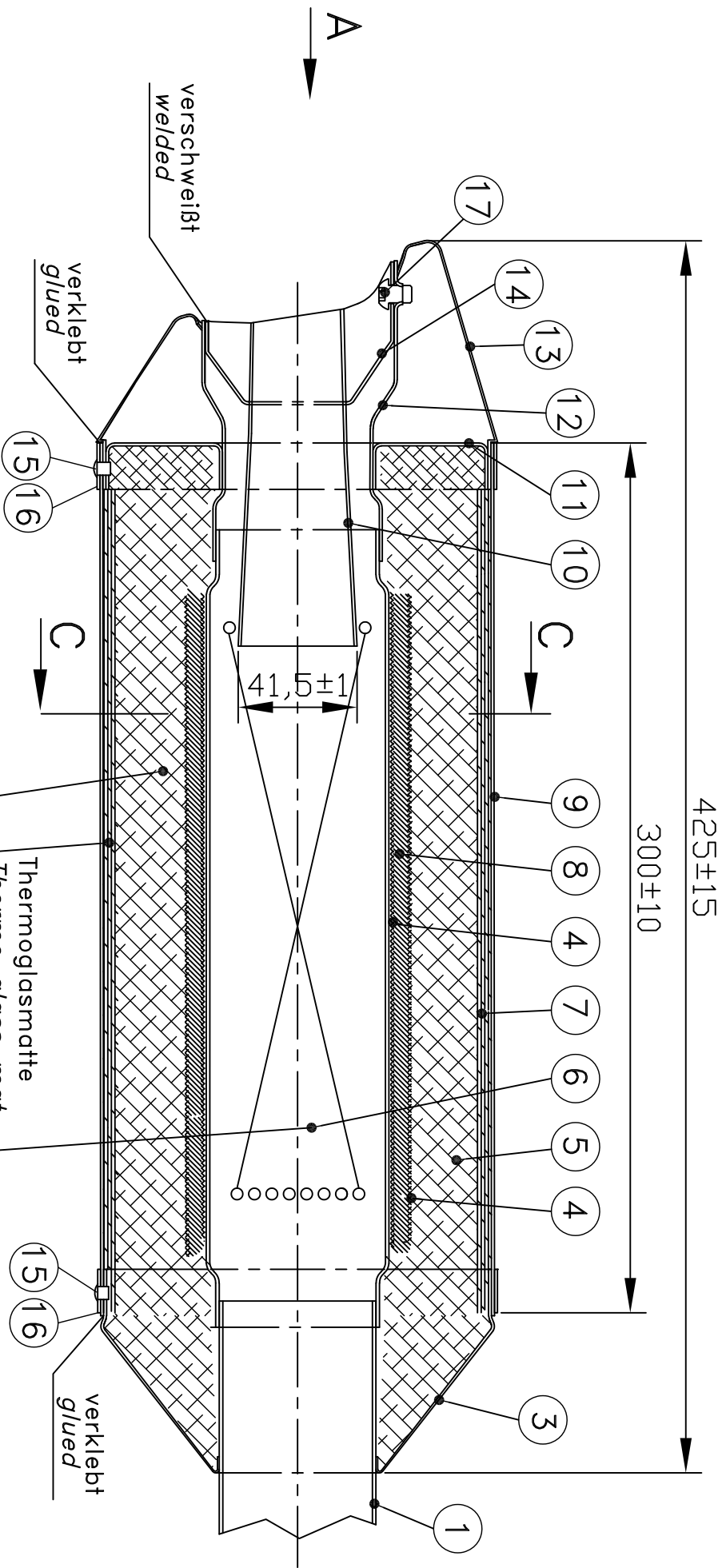
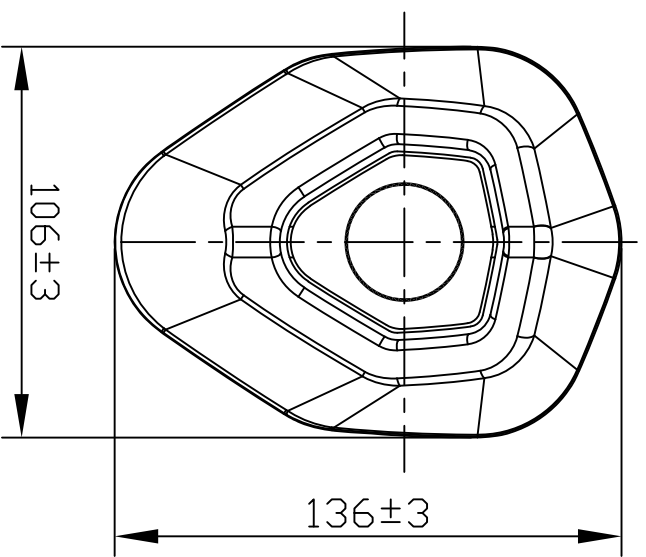

Innenrohr gelocht  
inner pipe perforated  
 $\varnothing 63 \pm 0,2 \times 1,2 \pm 0,3 \times 275 \pm 10$   
 1600 Löcher/holes +20% -10%  $\varnothing 3,5 \text{mm} \pm 0,5$

	Datum/date	Name	Zeichnung/drawing-no.	R E M U S
Gez.:	06.10.20	TM	20ESD10061.1	Typ: HX13
Gepr.:	06.10.20	VL		
Geän.:			Gepr.:	
Schalldämpfer/ silencer f. KTM 790/890 Adventure				



## STÜCKLISTE / parts list

Pos. Nr.: Pos. Nr.:	Benennung description	Norm norm	Abmessungen dimensions	Werkstoff basis material	Stk. Einh. piece unity	Men.
1	Einlaßrohr Inlet pipe	DIN2465	Ø54±0,3x1,2±0,3x660±20	B opt. C	1	mm
2	Anschlussring connecting ring	DIN 2465	Ø64/ Ø54±1x1,2±0,3x10±1	B opt. C	1	mm
3	Einlaßkappe Inlet cap		106±3x136±3x1,2±0,3x56±3	A opt.B opt.D	1	Stk
4	Drahtmaschengitter/ Ø 0,16±0,04 ; w = 0,4±0,1 wire mesh		240±10x210±10	B	2	Stk
5	Dämpfungsmaterial damping material			Glasfasermatte glass fibre matt	300	g +20%-10%
6	Innenrohr gelocht inner pipe perforated	DIN2465	Ø63±0,2x1,2±0,3x275±10 1600 Löcher/holes+20%-10% Ø3,5mm+0-0,5	B opt. C	1	mm
7	Dämpfungsmaterial damping material			Thermoglasmatte Thermo glass mat	200	g +20%-10%
8	Dämpfungsmaterial damping material			Edelstahlwolle stainless steel wool	60	g +20%-10%
9	Schalldämpfermantel	DIN1541	106±3x136±3x1,3±0,3x300±10 106±3x136±3x1,2±0,3x300±10 106±3x136±3x1,3±0,3x300±10	A opt.B opt.C	1	Stk
10	Innenrohr konisch inner pipe conical	DIN2465	Ø32/ Ø41,5x1,2±0,3x132±5	B opt. C	1	mm
11	Deckel cover plate	DIN 1541	103±3x133±3x1,2±0,3x12±3 ww.103±3x133±3x1,2±0,3x12±3 ww.103±3x133±3x1,2±0,3x12±3	A opt.B opt.C	1	mm
12	Innenrohr ungelocht inner pipe unperforated	DIN2465	Ø54x1,2±0,3x160±5	B opt. C	1	mm
13	Endkappe End cap		106±3x136±3x1,5±0,25x75±3	B opt. D	1	Stk
14	Innenrohr ungelocht inner pipe unperforated	DIN1541	Ø48±2x1,2±0,5 x63±5	B opt. C	1	mm
15	Nietband rivet strap		15x1x410±5	B opt. C	2	Stk
16	Niete/ rivet	XCAP EE	4,5x9	B	12 ±4	Stk
17	Schraube/ screw	ISO7380	M6x8	B	1	Stk

Werkstoff/material	Variante/variant
Carbon	A
Edelstahl / stainless steel 1.4301;1.4509;1.4512	B
Titan / titan	C
Kunststoff / plastic PA6.6-GF	D

Datum/date	Name	Zeichnungsnr/drawing-no	REMUS
Gez.: 06.10.20	TM	20ESD10061.2	Typ HX13
Gep.: 06.10.20	VL		
Geä.:	Gep.:		
Schalldämpfer für Motorrad/silencer for motorcycle			



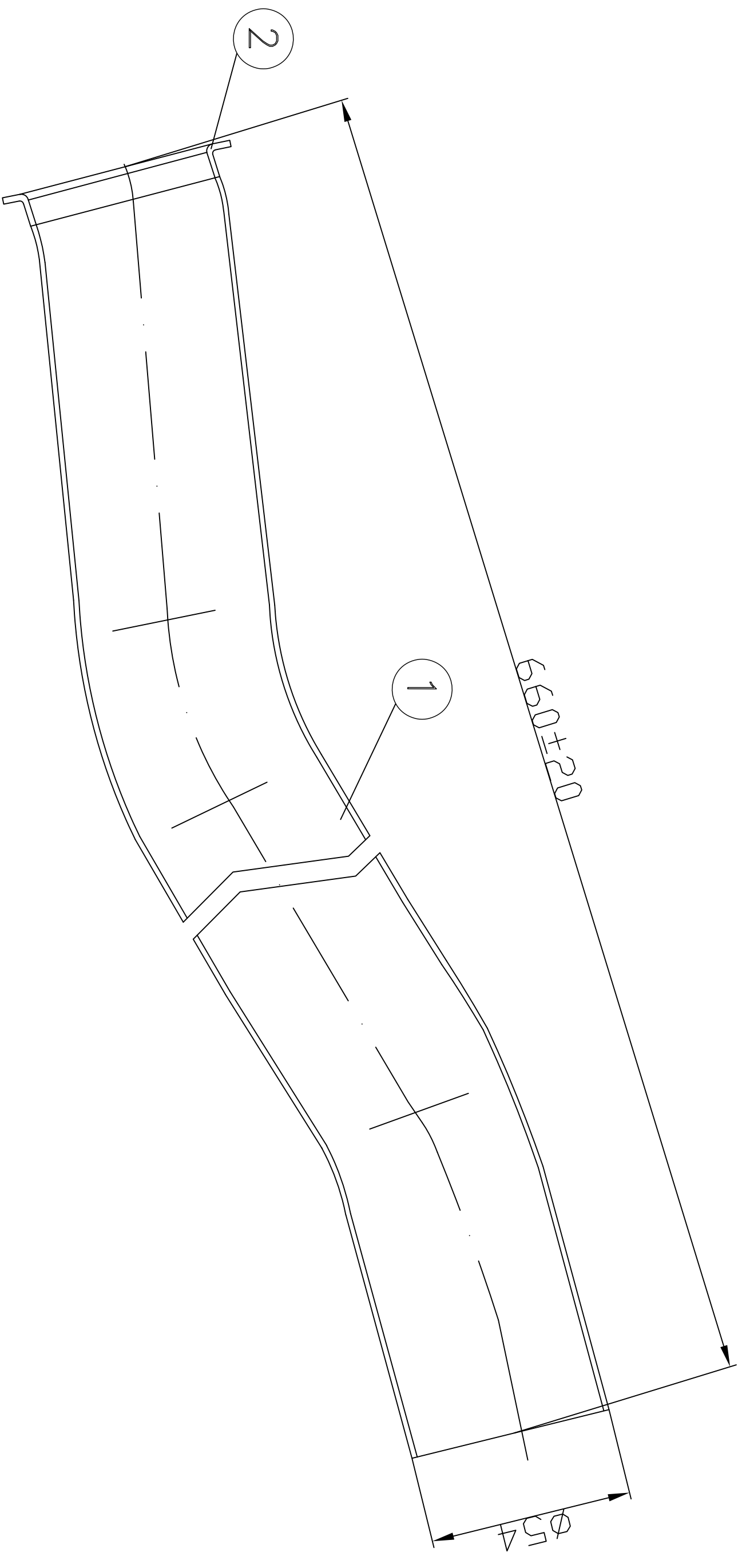

	Datum/ <i>date</i>	Name	Zeichnungnr/ <i>drawing-no.</i>	R E M U S
Gez.:	06.10.20	TM	20ESD10061.3	Typ: HX13
Gepr.:	06.10.20	VL		
Geän.:			Gepr.:	
Schalldämpfer / <i>silencer</i> f. KTM 790/890 Adventure				

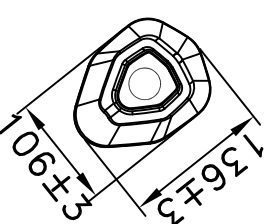
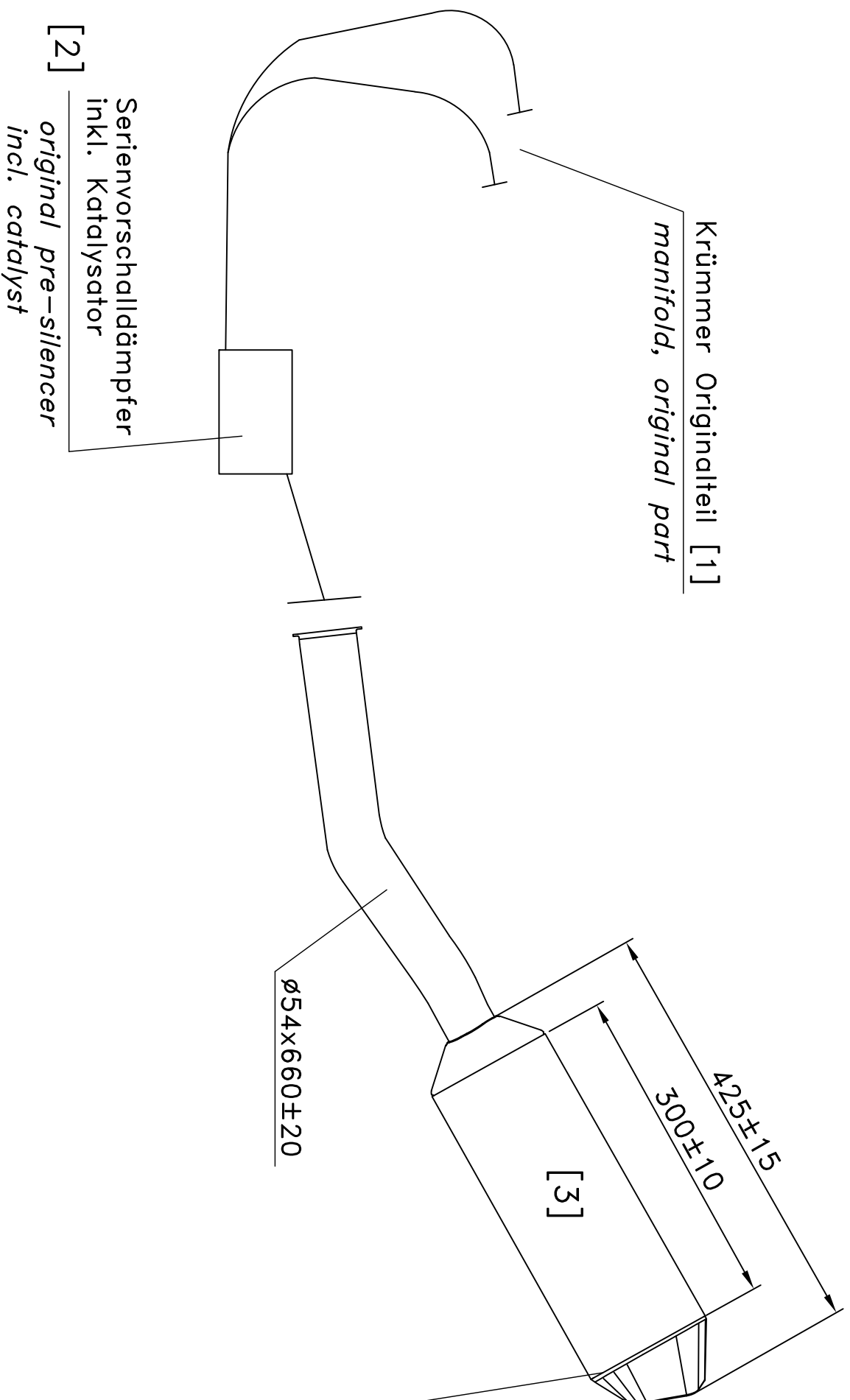

Kennzeichnung(Laser) am Nietband  
*Lasermarking on the rivet belt*

**REMUS**

Typ HX13

e... ..

	<i>Datum/date</i>	<i>Name</i>	<i>Zeichnungs-/drawing-no.</i>	<i>R E M U S</i>
<i>Gez.:</i>	06.10.20	TM	20ESD10061.4	<i>Typ: HX13</i>
<i>Gepr.:</i>	06.10.20	VL		
<i>Geän.:</i>			<i>Gepr.:</i>	
<i>Schalldämpfer / silencer f. KTM 790/890 Adventure</i>				



# INSTALLATION INSTRUCTIONS

KTM 890 Adventure | 2020 →

EXHAUST SYSTEM:  
Slip-on

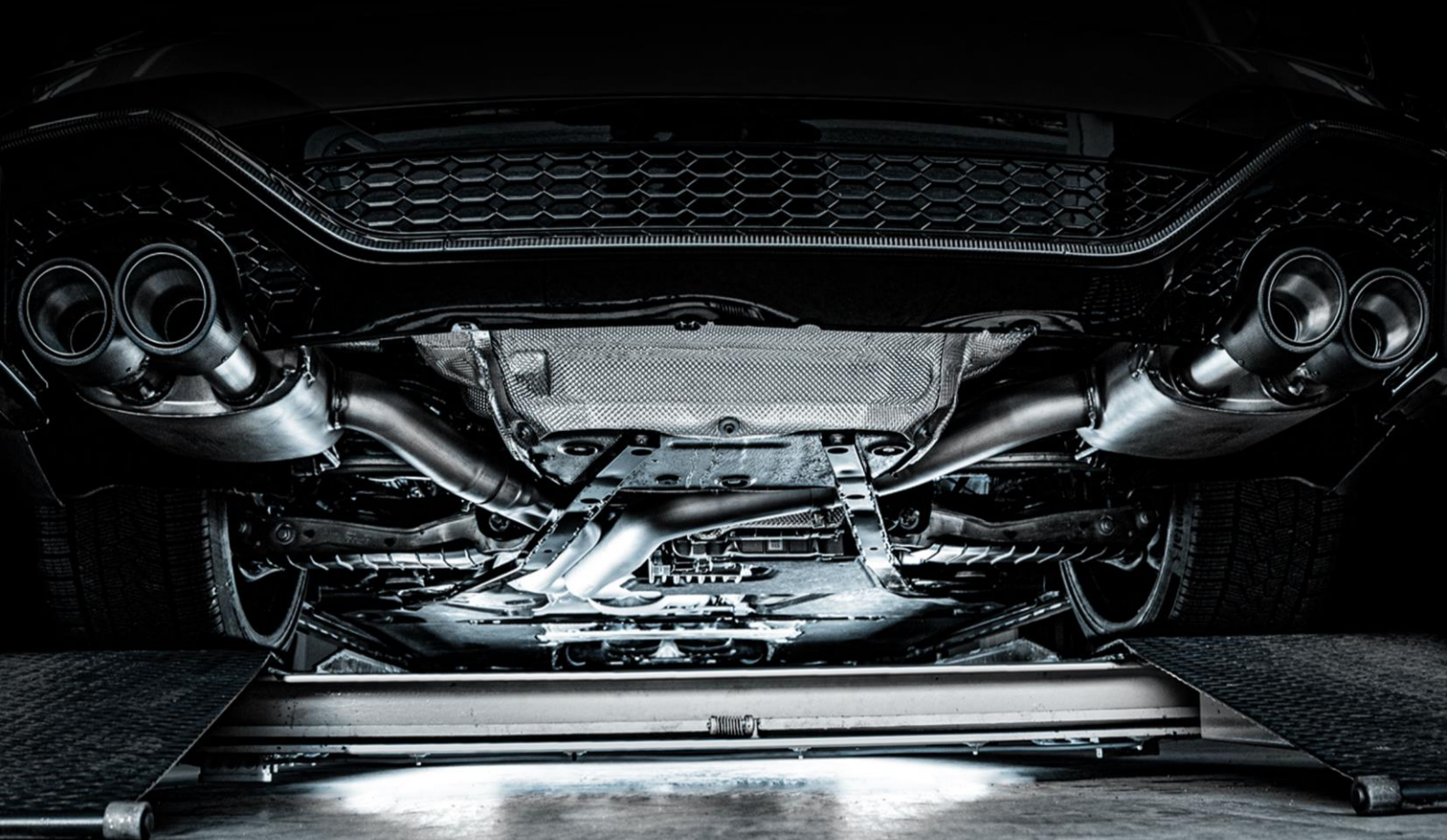

# SYMBOLS

The following symbols are used throughout these installation instructions:



**TOOLS AND PROTECTIVE EQUIPMENT REQUIRED**



**TIGHTENING TORQUE**



**LUBRICATION**



**HAND TIGHTEN**



**INSTALLATION TIP**



**CAUTION OR IMPORTANT**



**MOVEMENT ARROW**



**INDICATOR ARROW**



## **CERAMIC PASTE**

For lubrication and corrosion protection on screws, bolts, fits and pins. Free of standard and heavy metals, prevents sticking and seizing, neutral to all known sealing materials, non toxic, up to +1400°C heat resistant, short term up to +1600°C, prevents wear and tear.



## **TOOLS AND EQUIPMENT**

Use appropriate safety equipment like eye protection and mechanic gloves! Use appropriate and working tools for mounting and dismantling of the exhaust system.



We congratulate you on buying a product from REMUS and thank you for your trust. We are always striving to offer the very best product for your vehicle through continuous innovation processes and usage of the latest technologies.

# READ THIS

**Please read this entire installation manual carefully prior to installing and using the REMUS exhaust system.**

REMUS exhaust system should only be installed by persons skilled in car/motorcycle exhaust system installation and performance. The instructions provided in this manual should be followed to ensure proper installation and safe use of the REMUS exhaust system. REMUS and/or its partners shall not be held liable for any damage or personal injury (including direct, indirect, or consequential damage) sustained as a result of improper installation of the REMUS exhaust system or its use and maintenance contrary to the instructions and warnings contained herein.

If you have any questions regarding the installation and/or proper use of the REMUS exhaust system or this manual, please contact your local REMUS partner.

For more information on the REMUS exhaust systems, see the official REMUS website at: <http://www.remus.eu>

## GENERAL INFORMATION

Your safety is our number one priority. Please drive your car/motorcycle responsibly, safely and always obey local traffic rules.

All statements made with regard to the exhaust system's compliance are made in respect of the exhaust system "as is". Any modifications of the REMUS exhaust system or its improper installation, use or maintenance that is not in accordance with this Installation manual, may result in severe damage to the exhaust system and/ or engine, as well as personal injury, and may affect the exhaust system's compliance with the legal requirements, such as exhaust system's air and/ or noise emissions (as an example, the car/motorcycle may not be suitable for use on public roads any longer), as well as warranty coverage.

The exhaust system may only be used in accordance with relevant laws and regulations, including state and federal, where applicable.

Damage caused by improper installation, use and maintenance of the REMUS exhaust system is not covered by the REMUS warranty. Please refer to the enclosed warranty with regard to the terms of our warranty.

Technical specifications of REMUS exhaust systems and related products are subject to change without notice.



# RIGHTS & NOTES

---

## **COPYRIGHT, OTHER RIGHTS NOTICE AND GENERAL NOTES**

The REMUS trademark, including corporate logos and emblems, are subject to copyright as well as trademark rights of REMUS, its licensors, or third persons authorizing REMUS to use them. Any reproduction, technical or other manipulation, translation, or other use of the copyright and/or trademark rights contained herein is prohibited without the explicit prior written consent of REMUS.

The same especially applies to the entire contents of this manual and/or any of its parts, including but not limited to technical specifications, instructions, graphs, photographs, and so on included in this manual.

The photographs and other illustrations in this manual are symbolic and are intended to help represent individual steps for proper installation and use, as well as for a general overview.

The actual component parts of the REMUS exhaust system may not entirely correspond to the photographs and other illustrations.

REMUS takes all copyright and other rights infringement cases under serious consideration. If you have any reason to believe that your exhaust system is not an original REMUS product, please contact our local partners or REMUS at [office@remus.at](mailto:office@remus.at)



# SAFETY WARNINGS

## IMPORTANT SAFETY WARNINGS, PLEASE READ CAREFULLY

The car/motorcycle should be in the off position throughout the whole dismantling and mounting process, as well as any other work done on the exhaust system!

Before dismantling the exhaust system, lock the car/motorcycle and remove the key from the vehicle to avoid electrical errors in the control units!

For proper dismantling and mounting of the exhaust system, it is recommended to use an certificated and tested lifting device.

The exhaust system can get extremely hot during and after it is used. Allow the exhaust and engine to cool down before touching it and beginning installation.

Make sure that you have all the parts necessary for the installation of your new REMUS exhaust system, according to the parts list in this manual. If any of the parts are missing, please do not proceed with uninstalling your stock exhaust system/installing the REMUS exhaust system and contact the retailer you bought the REMUS exhaust system from.

**CAUTION:** make sure not to injure yourself or damage any part of the vehicle during dismantling and mounting of the exhaust systems!

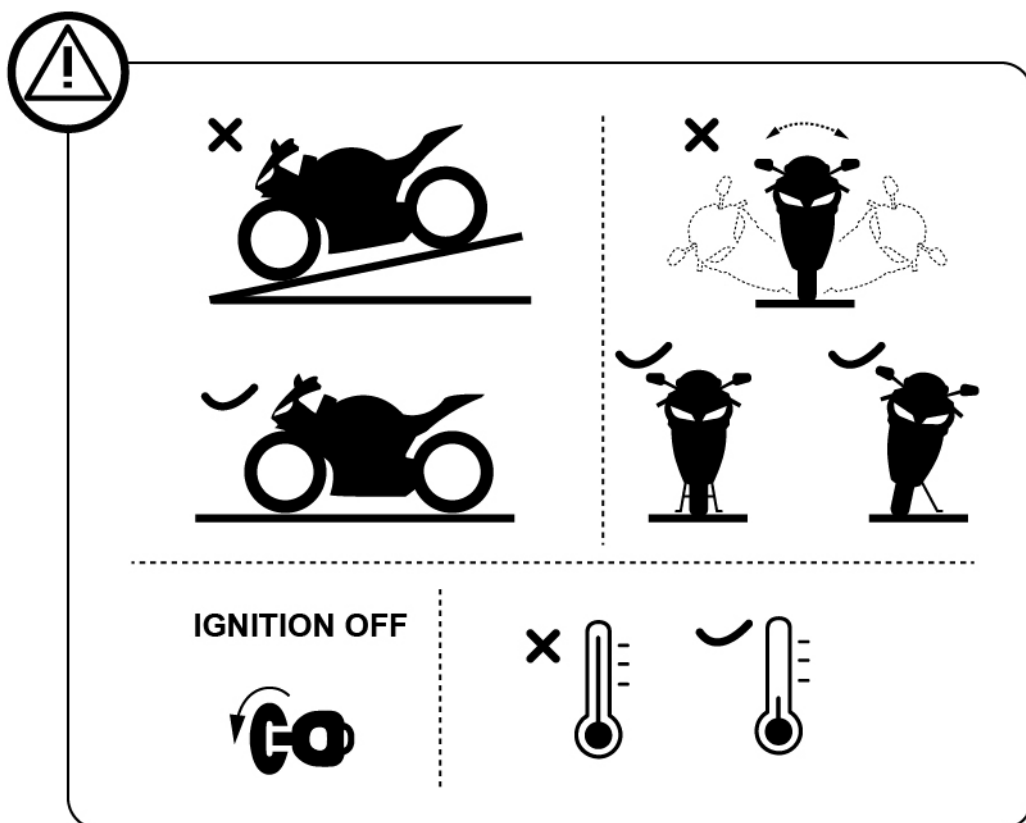

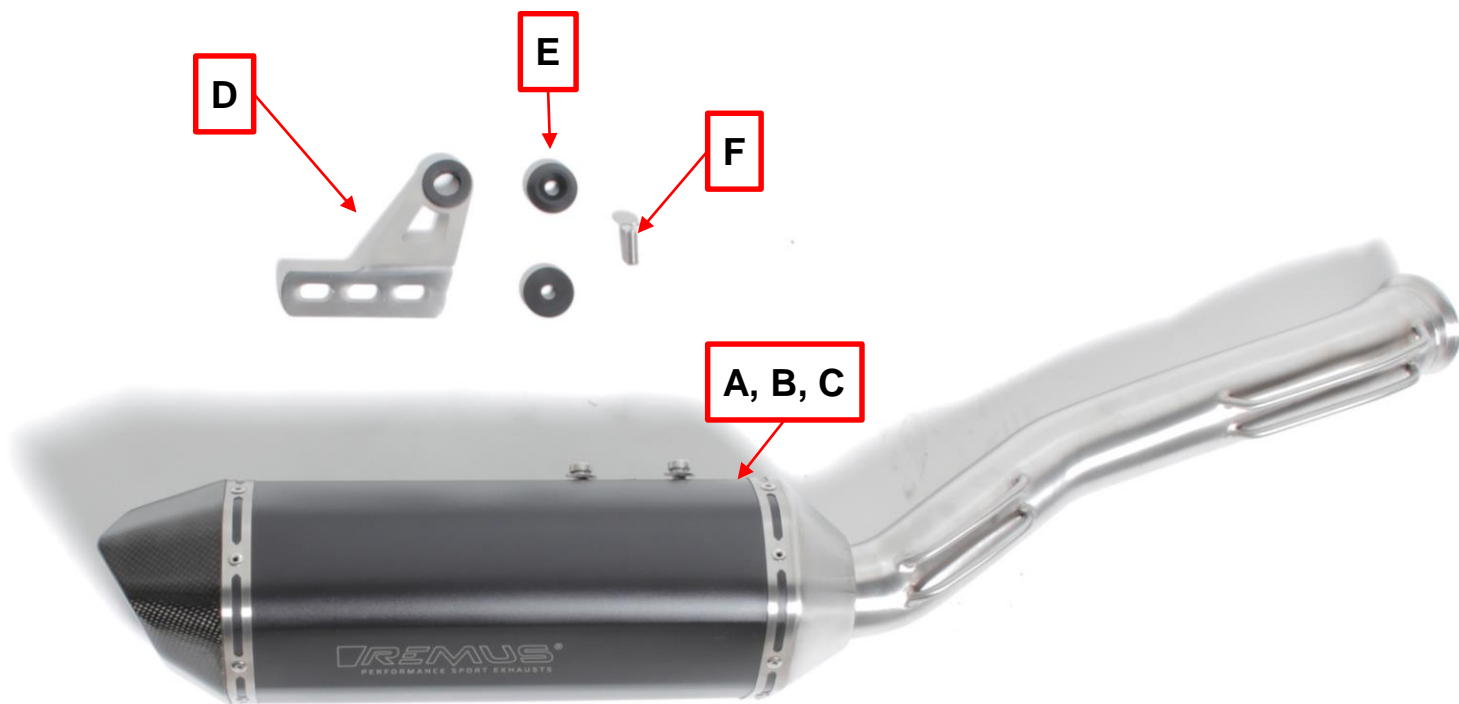

pos	pcs	packing content
A	1	sport exhaust
B	2	hex socket screw M8x16 mm (premounted)
C	2	washer M8 (premounted)
D	1	bracket
E	2	spacer M8
F	1	countersunk screw M8x25mm
G	1	ceramic paste
H	1	pair of gloves

# REMOVAL

---

## OF STOCK EXHAUST SYSTEM:

The process of uninstalling the original exhaust system may vary depending on the existing exhaust system. Please follow the original exhaust system manufacturer's instructions for uninstalling the original exhaust system.

If you for any reason decide otherwise, please note that any information provided in this respect herein should be considered as general information provided for your convenience only.

REMUS shall not assume any liability or responsibility with regard to uninstalling your existing exhaust system, warranty coverage of such exhaust system or vehicle or their further fitness for use.



## REMOVAL OF STOCK EXHAUST SYSTEM:



Loosen the bracket's screw as well as the clamp and remove the serial muffler.



# INSTALLATION OF THE REMUS EXHAUST SYSTEM

Install the supplied bracket onto the REMUS sport exhaust.

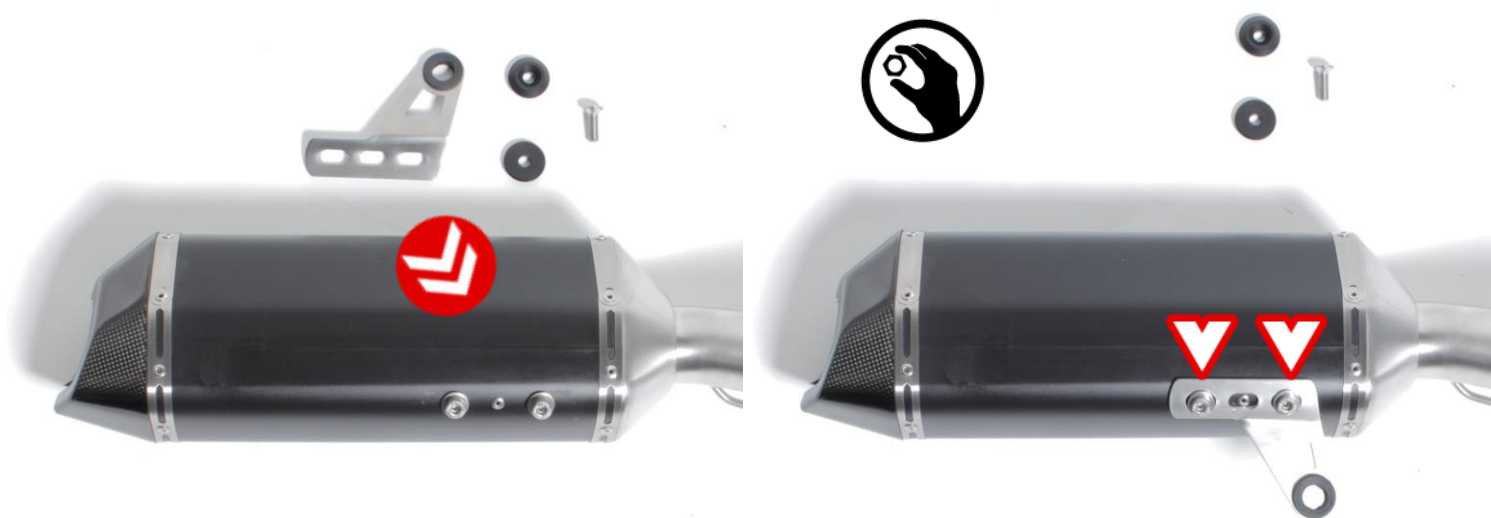

Mount both spacers onto the previously installed bracket.





Mount the sport exhaust onto the serial header using the serial clamp and slightly tighten the bracket's screw.



Align the REMUS sport exhaust and tighten all connections.



# FINAL STEPS

**IMPORTANT:** reinstall the dismantled or partially removed stock parts (wheel arches, bumper etc.); check vehicle manufacturer manual for tightening torques.

**IMPORTANT:** make sure all the nuts and bolts are sufficiently tightened. In case the exhaust system touches the cowling or other parts, repeat the adjustment of the exhaust system or contact your authorized dealer.

**IMPORTANT:** clean all exhaust components before the first start of the engine or the stains will burn onto the surfaces!

# TROUBLESHOOTING

Problem	Possible cause	Solution
Exhaust gas is leaking out of the exhaust system	loosened clamp	tighten all connections to specified torque
	connection is not completely joined	loosen the connection and tap it into place, tighten the connection to specified torque
Valve is not working / moving	Valve is mechanical stuck	Remove the actuator and try to move the valve by hand. Use spray lubricant (WD-40® or equivalent) to make the valve working again.
	Valve is not working correct	Make sure the actuator is powered correctly. Make sure the actuator is mounted properly onto the valve and the valve spins correctly.
Exhaust system rattles / doesn't fit properly	Exhaust System is not mounted correct	loosen all connections again and readjust/align the whole system once more



# MAINTENANCE

## **STAINLESS STEEL PARTS:**

Clean stainless steel components with soft cloth sprayed with contact cleaner, then wipe with soft and dry cloth.

## **CARBON PARTS:**

Clean carbon fiber exhaust components with soft and dry cloth.

## **TITANIUM PARTS:**

Clean the titanium exhaust components with a multi-purpose spray lubricant (WD-40® or equivalent).

A change in the color of the exhaust system is normal due to high temperatures. Periodically make sure all the bolts and springs are sufficiently tight.



**IT IS NORMAL FOR WHITE SMOKE TO COME OUT OF THE MUFFLER AT FIRST OPERATION.**

**⚠ CAUTION: DO NOT STAND BEHIND THE MUFFLER AT ANY TIME.**

**⚠ CAUTION: DO NOT USE AUTOMOTIVE WHEEL CLEANERS OR ANY CLEANING PRODUCTS WHICH CONTAIN ACIDIC ADDITIVES TO CLEAN THE REMUS EXHAUST SYSTEMS.**



# THE SOUND OF **REMUS**®

FIRST CLASS QUALITY DESIGNED & BUILT IN EUROPE | AUSTRIA

[www.remus.eu](http://www.remus.eu)

 **REMUS Innovation GmbH**  
Ruhmannstraße 11  
A-8570 Voitsberg

ENG

# INSTALLATION INSTRUCTIONS

---

22105979000C1

# SYMBOLS

The following symbols are used throughout these installation instructions:



**TOOLS AND PROTECTIVE EQUIPMENT REQUIRED**



**TIGHTENING TORQUE**



**LUBRICATION**



**HAND TIGHTEN**



**INSTALLATION TIP**



**CAUTION OR IMPORTANT**



**MOVEMENT ARROW**



**INDICATOR ARROW**



## **CERAMIC PASTE**

For lubrication and corrosion protection on screws, bolts, fits and pins. Free of standard and heavy metals, prevents sticking and seizing, neutral to all known sealing materials, non toxic, up to +1400°C heat resistant, short term up to +1600°C, prevents wear and tear.



## **TOOLS AND EQUIPMENT**

Use appropriate safety equipment like eye protection and mechanic gloves! Use appropriate and working tools for mounting and dismantling of the exhaust system.



We congratulate you on buying a product from REMUS and thank you for your trust. We are always striving to offer the very best product for your vehicle through continuous innovation processes and usage of the latest technologies.

# READ THIS

**Please read this entire installation manual carefully prior to installing and using the REMUS exhaust system.**

REMUS exhaust system should only be installed by persons skilled in car/motorcycle exhaust system installation and performance. The instructions provided in this manual should be followed to ensure proper installation and safe use of the REMUS exhaust system. REMUS and/or its partners shall not be held liable for any damage or personal injury (including direct, indirect, or consequential damage) sustained as a result of improper installation of the REMUS exhaust system or its use and maintenance contrary to the instructions and warnings contained herein.

If you have any questions regarding the installation and/or proper use of the REMUS exhaust system or this manual, please contact your local REMUS partner.

For more information on the REMUS exhaust systems, see the official REMUS website at: <http://www.remus.eu>

## GENERAL INFORMATION

Your safety is our number one priority. Please drive your car/motorcycle responsibly, safely and always obey local traffic rules.

All statements made with regard to the exhaust system's compliance are made in respect of the exhaust system "as is". Any modifications of the REMUS exhaust system or its improper installation, use or maintenance that is not in accordance with this Installation manual, may result in severe damage to the exhaust system and/ or engine, as well as personal injury, and may affect the exhaust system's compliance with the legal requirements, such as exhaust system's air and/ or noise emissions (as an example, the car/motorcycle may not be suitable for use on public roads any longer), as well as warranty coverage.

**If the REMUS exhaust system is manipulated in any way, the type approval is no longer valid!**

The exhaust system may only be used in accordance with relevant laws and regulations, including state and federal, where applicable.

Damage caused by improper installation, use and maintenance of the REMUS exhaust system is not covered by the REMUS warranty. Please refer to the enclosed warranty with regard to the terms of our warranty.

Technical specifications of REMUS exhaust systems and related products are subject to change without notice.



# RIGHTS & NOTES

---

## **COPYRIGHT, OTHER RIGHTS NOTICE AND GENERAL NOTES**

The REMUS trademark, including corporate logos and emblems, are subject to copyright as well as trademark rights of REMUS, its licensors, or third persons authorizing REMUS to use them. Any reproduction, technical or other manipulation, translation, or other use of the copyright and/or trademark rights contained herein is prohibited without the explicit prior written consent of REMUS.

The same especially applies to the entire contents of this manual and/or any of its parts, including but not limited to technical specifications, instructions, graphs, photographs, and so on included in this manual.

The photographs and other illustrations in this manual are symbolic and are intended to help represent individual steps for proper installation and use, as well as for a general overview.

The actual component parts of the REMUS exhaust system may not entirely correspond to the photographs and other illustrations.

REMUS takes all copyright and other rights infringement cases under serious consideration. If you have any reason to believe that your exhaust system is not an original REMUS product, please contact our local partners or REMUS at [office@remus.at](mailto:office@remus.at)



# SAFETY WARNINGS

## IMPORTANT SAFETY WARNINGS, PLEASE READ CAREFULLY

The car/motorcycle should be in the off position throughout the whole dismantling and mounting process, as well as any other work done on the exhaust system!

Before dismantling the exhaust system, lock the car/motorcycle and remove the key from the vehicle to avoid electrical errors in the control units!

For proper dismantling and mounting of the exhaust system, it is recommended to use an certificated and tested lifting device.

The exhaust system can get extremely hot during and after it is used. Allow the exhaust and engine to cool down before touching it and beginning installation.

Make sure that you have all the parts necessary for the installation of your new REMUS exhaust system, according to the parts list in this manual. If any of the parts are missing, please do not proceed with uninstalling your stock exhaust system/installing the REMUS exhaust system and contact the retailer you bought the REMUS exhaust system from.

**CAUTION:** make sure not to injure yourself or damage any part of the vehicle during dismantling and mounting of the exhaust systems!

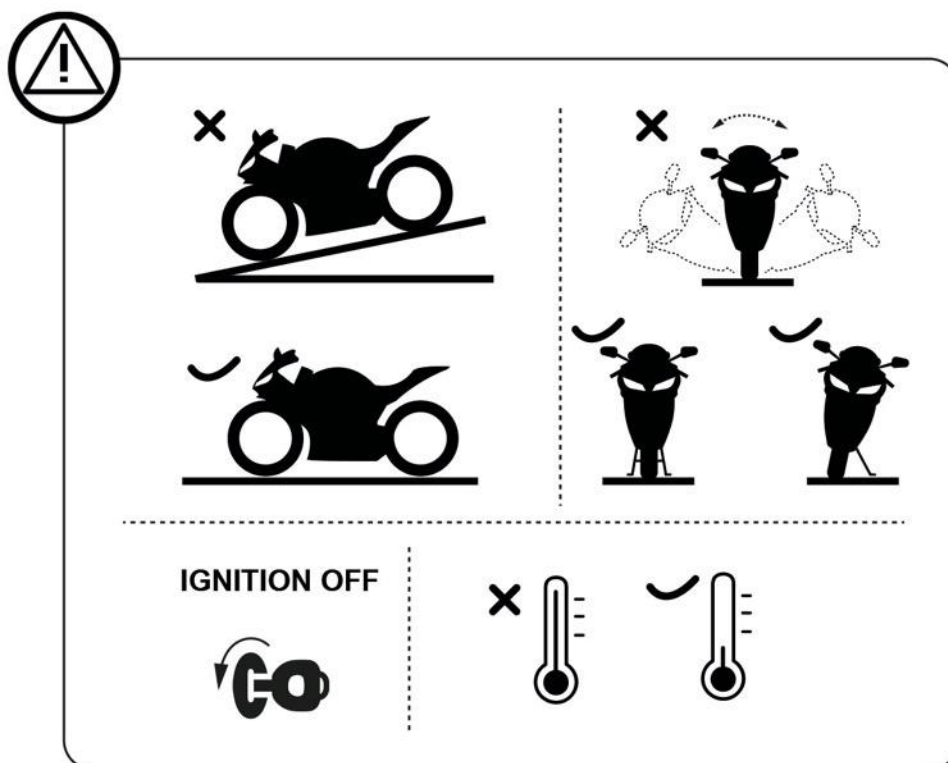

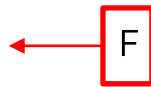
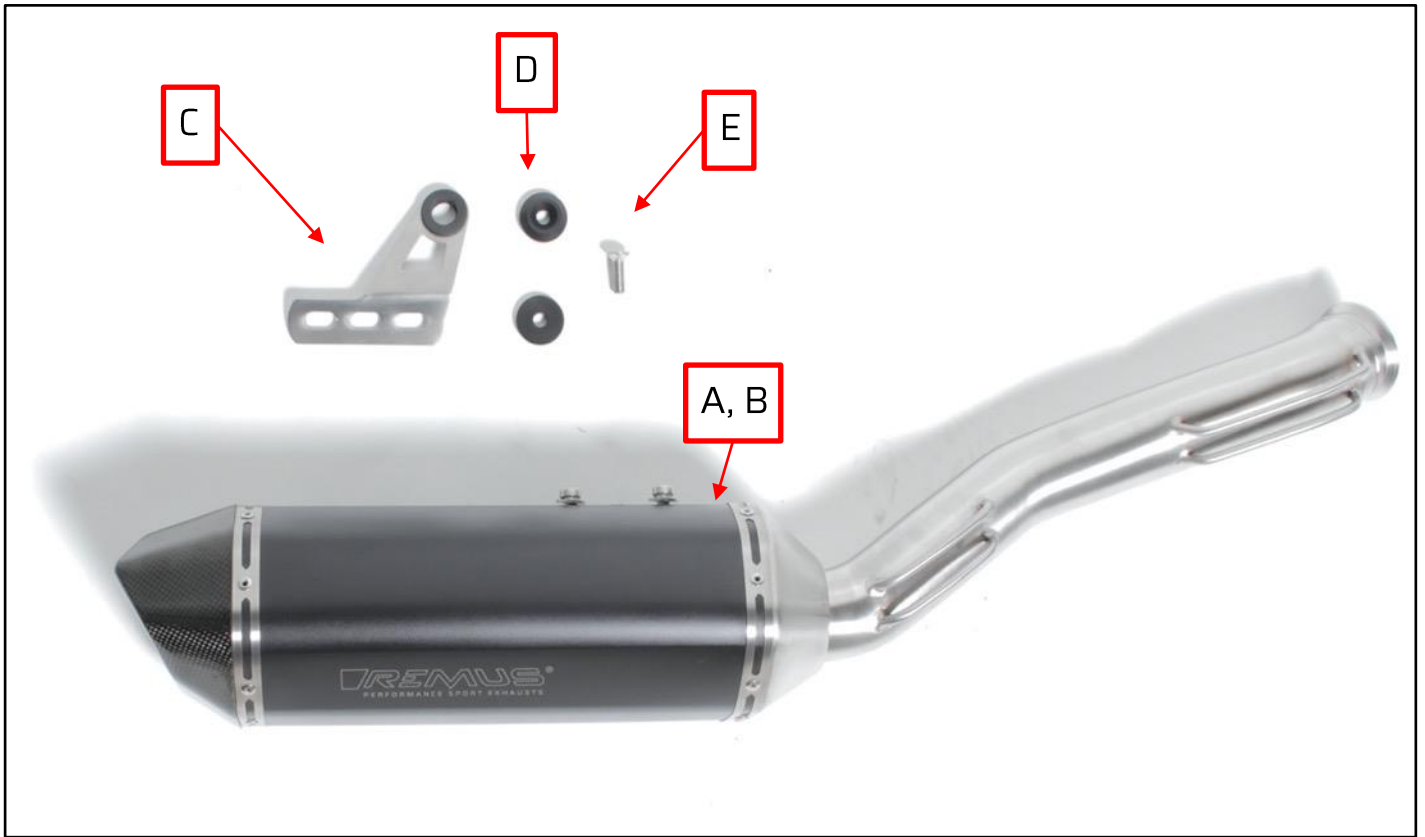

pos	pcs	packing content
A	1	sport exhaust
B	2	screw M8x16 mm (premounted)
C	1	bracket
D	2	spacer M8
E	1	countersunk screw M8x25mm
F	1	ceramic paste
G	1	pair of gloves



# REMOVAL

## OF STOCK EXHAUST SYSTEM:

The process of uninstalling the original exhaust system may vary depending on the existing exhaust system. Please follow the original exhaust system manufacturer's instructions for uninstalling the original exhaust system.

If you for any reason decide otherwise, please note that any information provided in this respect herein should be considered as general information provided for your convenience only.

REMUS shall not assume any liability or responsibility with regard to uninstalling your existing exhaust system, warranty coverage of such exhaust system or vehicle or their further fitness for use.



## REMOVAL OF STOCK EXHAUST SYSTEM:



Loosen the bracket's screw as well as the clamp and remove the serial muffler.



# INSTALLATION OF THE REMUS EXHAUST SYSTEM

Install the supplied bracket onto the REMUS sport exhaust.

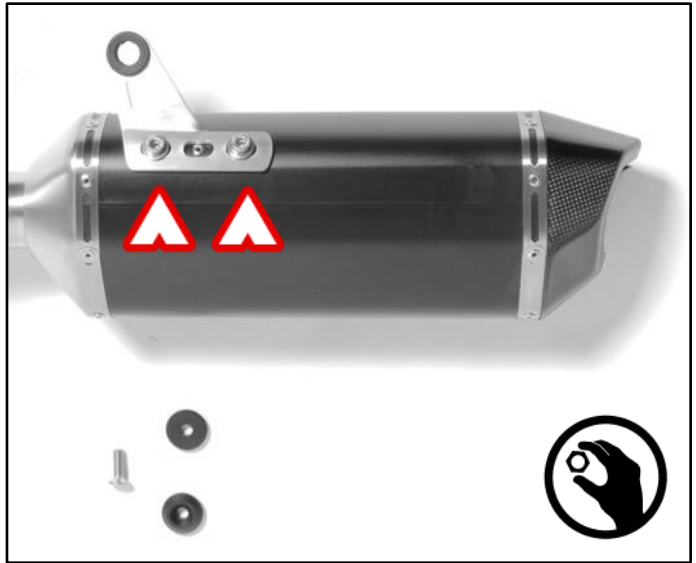

Mount both spacers onto the previously installed bracket.





Mount the sport exhaust onto the serial header using the serial clamp and slightly tighten the bracket's screw.



Align the REMUS sport exhaust and tighten all connections.

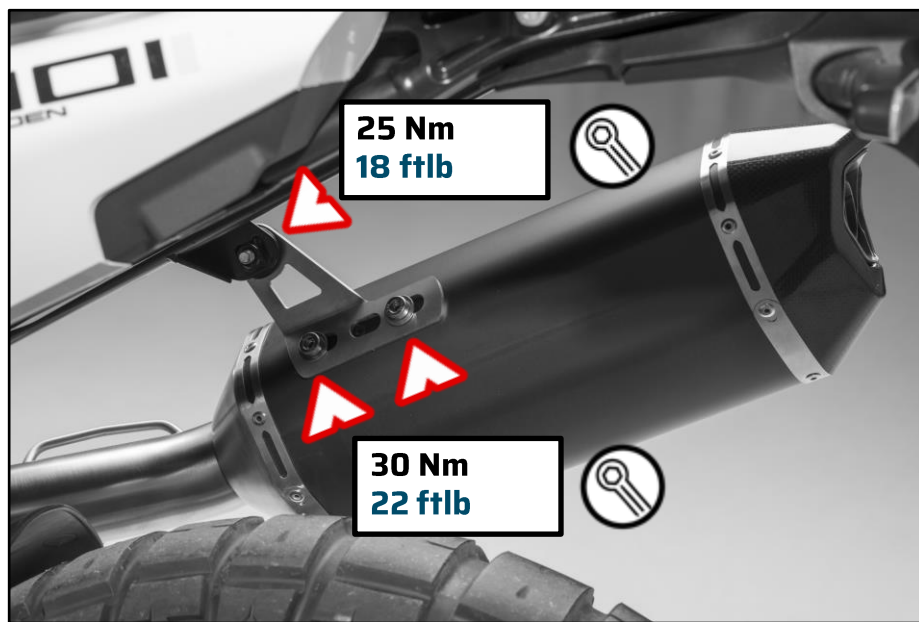

# FINAL STEPS

**IMPORTANT:** reinstall the dismantled or partially removed stock parts (wheel arches, bumper etc.); check vehicle manufacturer manual for tightening torques.

**IMPORTANT:** make sure all the nuts and bolts are sufficiently tightened. In case the exhaust system touches the cowling or other parts, repeat the adjustment of the exhaust system or contact your authorized dealer.

**IMPORTANT:** clean all exhaust components before the first start of the engine or the stains will burn onto the surfaces!

# TROUBLESHOOTING

Problem	Possible cause	Solution
Exhaust gas is leaking out of the exhaust system	loosened clamp	tighten all connections to specified torque
	connection is not completely joined	loosen the connection and tap it into place, tighten the connection to specified torque
Valve is not working / moving	Valve is mechanical stuck	Remove the actuator and try to move the valve by hand. Use spray lubricant (WD-40® or equivalent) to make the valve working again.
	Valve is not working correct	Make sure the actuator is powered correctly. Make sure the actuator is mounted properly onto the valve and the valve spins correctly.
Exhaust system rattles / doesn't fit properly	Exhaust System is not mounted correct	loosen all connections again and readjust/align the whole system once more



# MAINTENANCE

## **STAINLESS STEEL PARTS:**

Clean stainless steel components with soft cloth sprayed with contact cleaner, then wipe with soft and dry cloth.

## **CARBON PARTS:**

Clean carbon fiber exhaust components with soft and dry cloth.

## **TITANIUM PARTS:**

Clean the titanium exhaust components with a multi-purpose spray lubricant (WD-40® or equivalent).

A change in the color of the exhaust system is normal due to high temperatures. Periodically make sure all the bolts and springs are sufficiently tight.



**IT IS NORMAL FOR WHITE SMOKE TO COME OUT OF THE MUFFLER AT FIRST OPERATION.**

**⚠ CAUTION: DO NOT STAND BEHIND THE MUFFLER AT ANY TIME.**

**⚠ CAUTION: DO NOT USE AUTOMOTIVE WHEEL CLEANERS OR ANY CLEANING PRODUCTS WHICH CONTAIN ACIDIC ADDITIVES TO CLEAN THE REMUS EXHAUST SYSTEMS.**



# THE SOUND OF **REMUS**®

FIRST CLASS QUALITY DESIGNED & BUILT IN EUROPE | AUSTRIA

[www.remus.eu](http://www.remus.eu)

 **REMUS Innovation GmbH**  
Ruhmannstraße 11  
A-8570 Voitsberg



## Statement of Compliance with the Additional Sound Emission Provision

REMUS Innovation GmbH attests that the non-original replacement exhaust silencing systems of this type  (type with regard to its sound emission pursuant to the  series of amendments to UN Regulation No. 41) comply with the applicable ASEP requirements of UN Regulation No. 41 during the type approval procedure and its production.

REMUS Innovation GmbH makes this statement in good faith, after having performed an appropriate evaluation of the sound emission performance of the non-original replacement exhaust silencing system in accordance with the requirements of UN Regulation No.92 during the type approval procedure and its production.

Date:

Name of authorized representative: Ing. Andreas Riegler

ANDREAS RIEGLER

Signature of authorized representative:



REMUS Innovation GmbH  
Ruhmannstraße 11, A-8570 Voitsberg  
Tel.: 0043 (0)3142 / 6900-0  
office@remus.at, www.remus.eu



www.remususa.com



www.remus.cn