



MINISTERIO
DE INDUSTRIA, ENERGÍA
Y TURISMO

DIRECCIÓN GENERAL DE INDUSTRIA Y
DE LA PEQUEÑA Y MEDIANA EMPRESA
SUBDIRECCIÓN GENERAL DE
CALIDAD Y SEGURIDAD INDUSTRIAL



L-E9-00.1377

Página / Page 1/2

COMUNICACIÓN / *COMMUNICATION*:

Concerniente a ⁽¹⁾: LA CONCESIÓN DE HOMOLOGACIÓN
LA EXTENSIÓN DE HOMOLOGACIÓN
LA DENEGACIÓN DE HOMOLOGACIÓN
LA RETIRADA DE HOMOLOGACIÓN
EL CESE DEFINITIVO DE PRODUCCIÓN

Concerning ⁽¹⁾: *APPROVAL GRANTED*
APPROVAL EXTENDED
APPROVAL REFUSED
APPROVAL WITHDRAWN
PRODUCTION DEFINITELY DISCONTINUED

de un tipo de dispositivo en aplicación del Reglamento N° 81
of a type of device pursuant to Regulation No.81.

N° de homologación / *Approval No.*: L-E9-00.1377

Extensión n° / *Extension No.*: ----

1. Marca de fábrica o comercial del dispositivo / *Manufacturer's name for the device*: DEPE
2. Tipo / *Type*: PW204
3. Breve descripción incluyendo las siguiente información / *Brief description including in particular the following information*:
 - 3.1. Dimensiones principales de la superficie reflectante / *Principal dimensions of the reflecting surface*:
Ver documentación técnica / *See technical documentation*
 - 3.2. Radio de curvatura nominal de la superficie reflectante / *Nominal radius of curvature of the reflecting surface*:
Ver informe / *See report*
4. Nombre y dirección del fabricante / *Manufacturer's name and address*:
DEPE INTERNATIONAL CO., LTD
NO.8 ALY. 20 LANE 511 YUNGDA RD. YUNGKANG DIST. TAINAN CITY TAIWAN 710
5. Si procede, nombre y dirección del representante del fabricante / *If applicable, name and address of manufacturer's representative*:
6. Presentado a homologación el / *Submitted for approval on*: 31/03/2016
7. Servicio técnico encargado de los ensayos de homologación / *Technical service responsible of approval tests*:
IDIADA

(1) Táchese lo que no procede / *Strike out what does not apply.*



MINISTERIO
DE INDUSTRIA, ENERGÍA
Y TURISMO

DIRECCIÓN GENERAL DE INDUSTRIA Y
DE LA PEQUEÑA Y MEDIANA EMPRESA
SUBDIRECCIÓN GENERAL DE
CALIDAD Y SEGURIDAD INDUSTRIAL



L-E9-00.1377

Página / Page 2/2

8. Fecha del acta de ensayos emitida por este servicio / *Date of report issued by that service*: 27/06/2016
9. Número de informe expedido por dicho servicio / *Number of report issued by that service*: TW15120012
10. Vehículo al que está destinado el dispositivo / *Vehicle which is destined the device*: Ver documentación técnica / *See technical documentation*
11. Se concede/~~deniega~~/~~extiende~~/~~retira~~ la homologación ⁽¹⁾ / *Approval granted/refused/extended/withdrawn ⁽¹⁾*
12. Motivos de la extensión (en su caso) / *Reason(s) of extension (if applicable)*: ----
13. Lugar / *Place*: Madrid
14. Fecha / *Date*: Ver firma electrónica / *See electronic signature*
15. Firma / *Signature*:

EL SUBDIRECTOR GENERAL DE CALIDAD Y SEGURIDAD INDUSTRIAL
Resolución P.D. 25-10-2012
16. Los documentos que se citan, con el número de homologación arriba indicado, pueden ser obtenidos a petición/ *The following documents, bearing the approval number shown above, are available on request*:
 - Informe del ensayo / *Test report*
 - Documentación suministrada por el fabricante / *Documentation supplied by the manufacturer*

(1) Táchese lo que no proceda / *Strike out what does not apply*

INFORME N° / REPORT No. TW15120012

RELATIVO A LA HOMOLOGACIÓN DE ESPEJOS RETROVISORES PARA VEHÍCULOS A MOTOR DE DOS RUEDAS CON O SIN SIDECAR SEGÚN EL REGLAMENTO 81.00 ECE / *CONCERNING THE APPROVAL OF REAR-VIEW MIRRORS OF TWO-WHEELED POWER-DRIVEN VEHICLES WITH OR WITHOUT SIDECAR, ACCORDING TO REGULATION 81.00 ECE*

Nombre y dirección del fabricante /
Manufacturer's name and address : DEPE INTERNATIONAL CO., LTD
NO.8 ALY. 20 LANE 511 YUNGDA RD. YUNGKANG
DIST. TAINAN CITY TAIWAN 710

Marca comercial / *Trade mark* : DEPE

Tipo / *Type* : PW204

Lugar y fecha de emisión del informe /
Place and date of test report issue : L'Albornar, Santa Oliva (Tarragona)
27/06/2016

CONCLUSIONES / *CONCLUSIONS*: El dispositivo presentado **CUMPLE** las prescripciones relativas a la homologación de espejos retrovisores para vehículos a motor de dos ruedas con o sin sidecar según el Reglamento N° 81.00 ECE, según se detalla en el anexo que se adjunta a este informe / *This device FULFILLS the prescriptions with regard to the approval of rear-view mirrors of two-wheeled power-driven vehicles with or without sidecar, according Regulation No.81.00 ECE, as detailed in the annex to this report.*

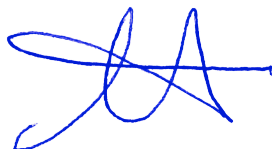
Realizado / *Performed by*:

Maria Recasens Bages
INGENIERO DE ENSAYOS
TEST ENGINEER

V. B° / *Revised by*:

Lluís Sans Gomis
JEFE DE DEPARTAMENTO
DEPARTMENT MANAGER

ANEXO AL INFORME /

ANNEX TO THE REPORT

RELATIVO A LA HOMOLOGACIÓN DE ESPEJOS RETROVISORES PARA VEHÍCULOS A MOTOR DE DOS RUEDAS CON O SIN SIDECAR SEGÚN EL REGLAMENTO 81.00 ECE / *CONCERNING THE APPROVAL OF REAR-VIEW MIRRORS OF TWO-WHEELED POWER-DRIVEN VEHICLES WITH OR WITHOUT SIDECAR, ACCORDING TO REGULATION 81.00 ECE*

Nombre y dirección del fabricante / *Manufacturer's name and address* : DEPE INTERNATIONAL CO., LTD
NO.8 ALY. 20 LANE 511 YUNGDA RD. YUNGKANG
DIST. TAINAN CITY TAIWAN 710

Marca comercial / *Trade mark* : DEPE

Tipo / *Type* : PW204

Clase / *Class* : L

Identificación de la muestra / *Sample identification* : TW15120012
Muestra A/*Sample A*: Lado derecho /*Right side*
Muestra B/*Sample B*: Lado izquierdo /*Left side*

MARCAJE / MARKING:

Marcaje / <i>Marking</i>	CORRECTO / CORRECT
--------------------------	-------------------------------

ESPECIFICACIONES GENERALES / GENERAL SPECIFICATIONS

Retrovisor regulable / <i>Adjustable rear-view mirror</i>	CORRECTO / CORRECT
Fuerza de penetración de la superficie reflectante / <i>Returning force of the reflecting surface</i> F= N < 50 Newtons	NO APLICABLE / NOT APPLICABLE
Contorno de la superficie reflectante $r \geq 2,5$ mm <i>Outline of reflecting surface: $r \geq 2,5$ mm</i>	CORRECTO / CORRECT
Puntos de contacto con una esfera de 100 mm de diámetro: / <i>Points of contact with a sphere of 100 mm diameter:</i> $r \geq 2,5$ mm	CORRECTO / CORRECT
Diámetro o diagonal < 12 mm : aristas redondeadas <i>Diameter or diagonal < 12 mm: rounded edges</i>	CORRECTO / CORRECT

* LOS RESULTADOS PRESENTADOS SE REFIEREN ÚNICAMENTE A LA MUESTRA ENSAYADA.
THE PRESENTED RESULTS REFER ONLY TO THE TESTED SAMPLE

* QUEDA TERMINANTEMENTE PROHIBIDA LA REPRODUCCION PARCIAL DE ESTE INFORME SIN PERMISO EXPRESO DE IDIADA.
THE PARTIAL REPRODUCTION OF THIS REPORT WITHOUT THE PERMISSION OF IDIADA IS COMPLETELY FORBIDDEN

RADIO DE CURVATURA DE LA SUPERFICIE REFLECTANTE / CURVATURE RADIUS OF THE REFLECTING SURFACE

Muestra A / Sample A

r = 1399.3 mm $1000 < r < 1500 \text{ mm}$	CORRECTO / CORRECT
--	---------------------------

Muestra B / Sample B

r = 1361.0 mm $1000 < r < 1500 \text{ mm}$	CORRECTO / CORRECT
--	---------------------------

COMPROBACIÓN DIMENSIONAL / DIMENSIONAL CHECKING

Superficie reflectante > 69 cm ² <i>Reflectance surface > 69 cm²</i>		CORRECTO / CORRECT
Retrovisores circulares (94 mm ≤ d ≤ 150 mm) <i>Circular rear view-mirrors(94 mm ≤ d ≤ 150 mm)</i>		CORRECTO / CORRECT
Retrovisores no circulares / <i>Non circular rear-view mirrors</i>	Se puede inscribir un círculo de 78mm de diametro en la superficie reflectante/ <i>It is possible to inscribe a 78 diameter circle in the reflectance surface.</i>	NO APLICABLE / NOT APPLICABLE
	La superficie reflectante se inscribe dentro de un rectángulo de 120x200mm/ <i>Reflectance surface is inscribed in a 120x200 mm rectangle</i>	NO APLICABLE / NOT APPLICABLE

ENSAYOS ÓPTICOS / OPTICAL TEST

Muestra A / <i>Sample A</i>	Reflexión regular en funcionamiento de día: 61.63 % ≥ 40% <i>Regular reflection in mode "day": 61.63 % ≥ 40%</i>	CORRECTO / CORRECT
Muestra B / <i>Sample B</i>	Reflexión regular en funcionamiento de día: 62.2 % ≥ 40% <i>Regular reflection in mode "day": 62.2 % ≥ 40%</i>	CORRECTO / CORRECT
Reflexión regular en funcionamiento de noche: ----≥ 4% <i>Regular reflection in mode "night":---- ≥ 4%</i>		NO APLICABLE / NOT APPLICABLE
Reconocimiento de los colores en funcionamiento de día <i>Identification of colours in mode "day"</i>		CORRECTO / CORRECT

ENSAYO DE FLEXIÓN / BENDING TEST

La superficie reflectante no se rompe o los fragmentos de cristal se adhieren a la carcasa o no exceden de 2,5 mm a ambos lados de la fisura / <i>Reflection surface does not brake or fragments of glass still adhere to the housing or doesn't exceed 2,5 mm either side of the crack.</i>	CORRECTO/ CORRECT
--	--------------------------

* LOS RESULTADOS PRESENTADOS SE REFIEREN UNICAMENTE A LA MUESTRA ENSAYADA.
THE PRESENTED RESULTS REFER ONLY TO THE TESTED SAMPLE

* QUEDA TERMINANTEMENTE PROHIBIDA LA REPRODUCCION PARCIAL DE ESTE INFORME SIN PERMISO EXPRESO DE IDIADA.
THE PARTIAL REPRODUCTION OF THIS REPORT WITHOUT THE PERMISSION OF IDIADA IS COMPLETELY FORBIDDEN

ENSAYO DE IMPACTO/ IMPACT TEST

Variante A / Variant A:

Impacto 1 (lado superficie reflectante): $\alpha= 55^\circ \geq 20^\circ$ <i>Impact 1 (Reflecting surface side) : $\alpha= 55^\circ \geq 20^\circ$</i>	CORRECTO / CORRECT
Impacto 2 (lado opuesto superficie reflectante) $\alpha= 25^\circ \geq 20^\circ$ <i>Impact 2(opposite side to the Reflecting surface) $\alpha= 25^\circ \geq 20^\circ$</i>	CORRECTO / CORRECT
La superficie reflectante no se rompe o los fragmentos de cristal se adhieren a la carcasa o no exceden de 2,5 mm a ambos lados de la fisura / <i>Reflection surface does not brake or fragments of glass still adhere to the housing or doesn't exceed 2,5 mm either side of the crack.</i>	CORRECTO/ CORRECT

Variante B / Variant B:

Impacto 1 (lado superficie reflectante): $\alpha= 58^\circ \geq 20^\circ$ <i>Impact 1 (Reflecting surface side) : $\alpha= 58^\circ \geq 20^\circ$</i>	CORRECTO / CORRECT
Impacto 2 (lado opuesto superficie reflectante) $\alpha= 60^\circ \geq 20^\circ$ <i>Impact 2(opposite side to the Reflecting surface) $\alpha= 60^\circ \geq 20^\circ$</i>	CORRECTO / CORRECT
La superficie reflectante no se rompe o los fragmentos de cristal se adhieren a la carcasa o no exceden de 2,5 mm a ambos lados de la fisura / <i>Reflection surface does not brake or fragments of glass still adhere to the housing or doesn't exceed 2,5 mm either side of the crack.</i>	CORRECTO/ CORRECT

Variante C / Variant C:

Impacto 1 (lado superficie reflectante): $\alpha= 60^\circ \geq 20^\circ$ <i>Impact 1 (Reflecting surface side) : $\alpha= 60^\circ \geq 20^\circ$</i>	CORRECTO / CORRECT
Impacto 2 (lado opuesto superficie reflectante) $\alpha= 60^\circ \geq 20^\circ$ <i>Impact 2(opposite side to the Reflecting surface) $\alpha= 60^\circ \geq 20^\circ$</i>	CORRECTO / CORRECT
La superficie reflectante no se rompe o los fragmentos de cristal se adhieren a la carcasa o no exceden de 2,5 mm a ambos lados de la fisura / <i>Reflection surface does not brake or fragments of glass still adhere to the housing or doesn't exceed 2,5 mm either side of the crack.</i>	CORRECTO/ CORRECT

Variante D / Variant D:

Impacto 1 (lado superficie reflectante): $\alpha= 62^\circ \geq 20^\circ$ <i>Impact 1 (Reflecting surface side) : $\alpha= 62^\circ \geq 20^\circ$</i>	CORRECTO / CORRECT
Impacto 2 (lado opuesto superficie reflectante) $\alpha= 46^\circ \geq 20^\circ$ <i>Impact 2(opposite side to the Reflecting surface) $\alpha= 46^\circ \geq 20^\circ$</i>	CORRECTO / CORRECT
La superficie reflectante no se rompe o los fragmentos de cristal se adhieren a la carcasa o no exceden de 2,5 mm a ambos lados de la fisura / <i>Reflection surface does not brake or fragments of glass still adhere to the housing or doesn't exceed 2,5 mm either side of the crack.</i>	CORRECTO/ CORRECT

* LOS RESULTADOS PRESENTADOS SE REFIEREN UNICAMENTE A LA MUESTRA ENSAYADA.
THE PRESENTED RESULTS REFER ONLY TO THE TESTED SAMPLE

* QUEDA TERMINANTEMENTE PROHIBIDA LA REPRODUCCION PARCIAL DE ESTE INFORME SIN PERMISO EXPRESO DE IDIADA.
THE PARTIAL REPRODUCTION OF THIS REPORT WITHOUT THE PERMISSION OF IDIADA IS COMPLETELY FORBIDDEN

Variante E / Variant E:

Impacto 1 (lado superficie reflectante): $\alpha= 25^\circ \geq 20^\circ$ <i>Impact 1 (Reflecting surface side) : $\alpha= 25^\circ \geq 20^\circ$</i>	CORRECTO / CORRECT
Impacto 2 (lado opuesto superficie reflectante) $\alpha= 22^\circ \geq 20^\circ$ <i>Impact 2(opposite side to the Reflecting surface) $\alpha= 22^\circ \geq 20^\circ$</i>	CORRECTO / CORRECT
La superficie reflectante no se rompe o los fragmentos de cristal se adhieren a la carcasa o no exceden de 2,5 mm a ambos lados de la fisura / <i>Reflection surface does not brake or fragments of glass still adhere to the housing or doesn't exceed 2,5 mm either side of the crack.</i>	CORRECTO/ CORRECT

Lugar del ensayo / *Test place*: **COLOR EYE LAB.** (Taiwan, R.O.C.)

Fecha del ensayo / *Test date*: 20/01/2016~31/03/2016

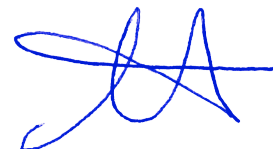

Maria Recasens Bages
INGENIERO DE ENSAYOS
TEST ENGINEER

* LOS RESULTADOS PRESENTADOS SE REFIEREN UNICAMENTE A LA MUESTRA ENSAYADA.
THE PRESENTED RESULTS REFER ONLY TO THE TESTED SAMPLE

* QUEDA TERMINANTEMENTE PROHIBIDA LA REPRODUCCION PARCIAL DE ESTE INFORME SIN PERMISO EXPRESO DE IDIADA.
THE PARTIAL REPRODUCTION OF THIS REPORT WITHOUT THE PERMISSION OF IDIADA IS COMPLETELY FORBIDDEN

DOCUMENTACIÓN TÉCNICA /
TECHNICAL DOCUMENTATION

帝沛企業有限公司

DEPE INTERNATIONAL CO., LTD
TEL: 06-2018012 FAX: 06-2028126

PAGE: 1/2

DATE: 20151218

INFORMATION FOLDER TECHNICAL DESCRIPTION

1. MANUFACTURER: DEPE INTERNATIONAL CO., LTD
NO.8 ALY. 20 LANE 511 YUNGDA RD.
YUNGKANG DIST. TAINAN CITY
TAIWAN 710

2. MANUFACTURER'S AUTHORIZED
REPRESENTATIVE:

3. APPLICABLE REGULATION: ECE R81

- 4.DEVICE NAME: REAR VIEW MIRROR FOR MOTOBIKES

- 5.DEVICE NUMBER: VARIANT A: PW204-1
VARIANT B:PW204-2
VARIANT C:PW204-3
VARIANT D:PW204-4
VARIANT E:PW204-5

- 6.CLASS: L(ECE)

- 7.TRADE MARK: DEPE

- 8.TYPE IDENTIFICATION: PW204

帝沛企業有限公司

DEPE INTERNATIONAL CO., LTD

TEL: 06-2018012 FAX: 06-2028126

INFORMATION FOLDER

PAGE:2/2

9.MOUNTING METHOD:

- 1) MOUNTING LOCATION: MOUNTING LOCATION: ON THE RIGHT & LEFT HAND SIDE OF MOTORCYCLE
- 2) ORIENTATION ANGLE: FEFER TO THE DRAWINGS
- 3) MOUNTING METHOD: FIX WITH ONE SCREW ON MOTORBIKE'S HANDLE.

10: CONSTRUCTION OF REFLECTING SURFACE:

- 1) RADIUS OF CURVATURE: 1350mm \pm 150mm
- 2) MIRROR THICKNESS: 2mm
- 3) MIRROR REFLECTIVE AREA: 94cm²

11. CONSTRUCTION OF COMPONENTS:

NO.	PARTS	MATERIAL
1.	HOUSING	ALUMINUM
2.	STEM	ALUMINUM
3.	GLASS	
4.	SCREW	IORN

12.TYPE OF VEHICLES: MOTORCYCLE&MOTOBIKE

13.REMARKS:

TYPE	MIRROR CONTROL SYSTEM
PW204	MANUAL CONTROL SYSTEM

Item	Qty	Part Number	Description	Material
1	1		Housing	Aluminum
2	1		Stem	Aluminum
3	1		Mirror	Glass
4	1		Bolt	Stainless

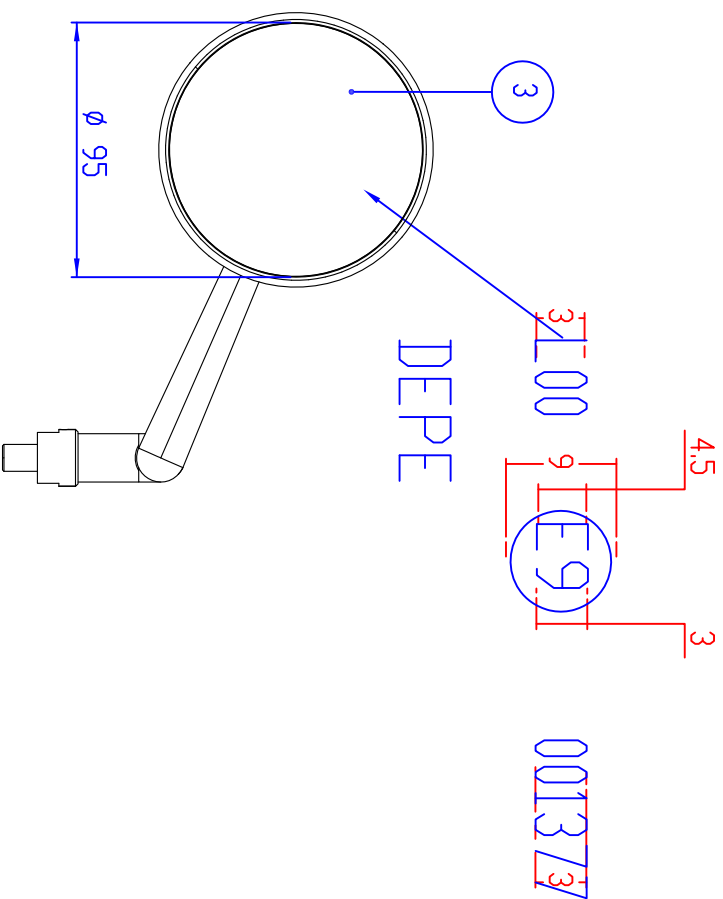
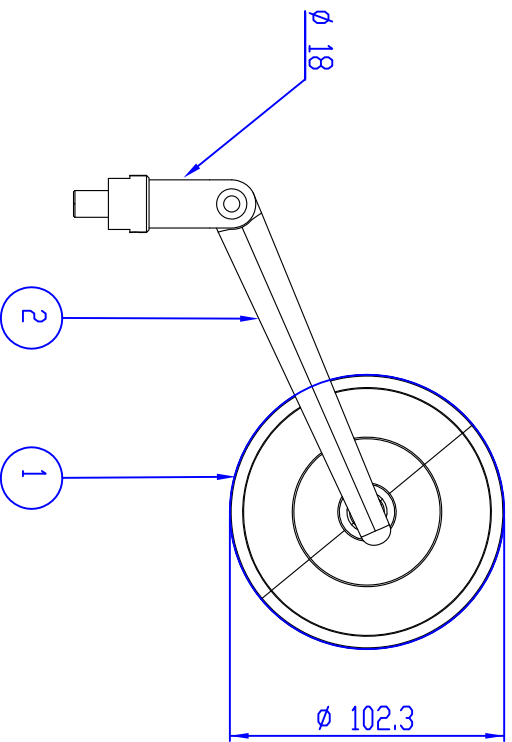
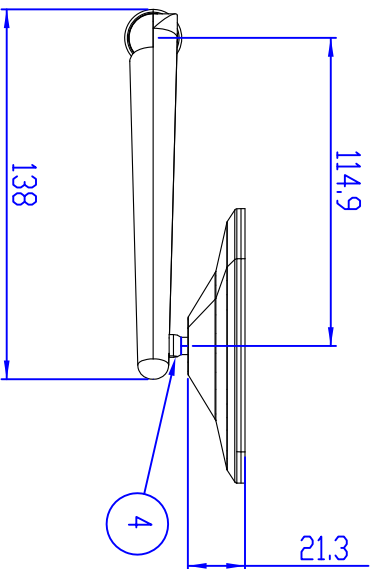

VARIANT A

TOL. UNLESS SPECIFIED		姓名	日期	表面處理 FINISH		DWG NO.		UNIT NO.
0 P/LC DEC. ± 0.30	1 P/LC DEC. ± 0.15	APPV/D	DATE	SIZE	(冊) REV	0	帝沛企業有限公司	機型
2 P/LC DEC. ± 0.05	ANGULAR : ±1°	主筆		A3	(圖) VER	0	DEPE INTERNATIONAL CO.,LTD	0
ALL DIMENSIONS mm		審核		比例 SCALE:		1:1		
第三角法		專務負責人		材質 MATERIAL:		0		
ECON NO	ECON	NAME	DATE	重量 WEIGHT:		0		
				052616		9		
				BOM NO.				

帝沛企業有限公司
DEPE INTERNATIONAL CO.,LTD

TITLE: PW/204

UNIT NO. 0

Item	Qty	Part Number	Description	Material
1	1		Housing	Aluminum
2	1		Stem	Aluminum
3	1		Mirror	Glass
4	1		Bolt	Stainless

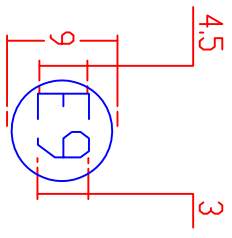
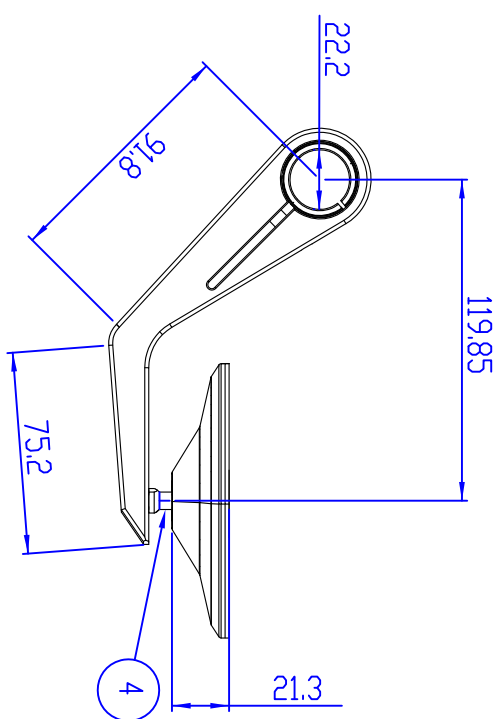

001377

DEPE

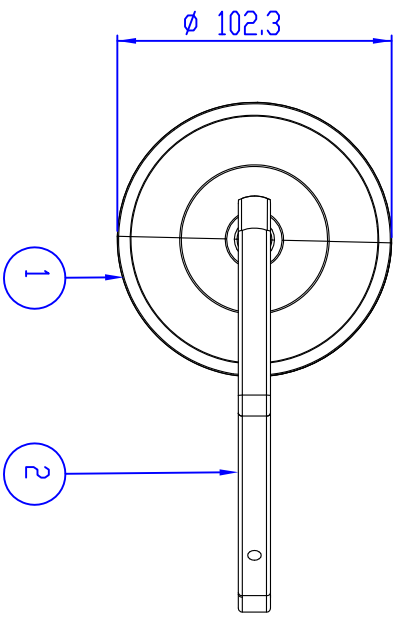
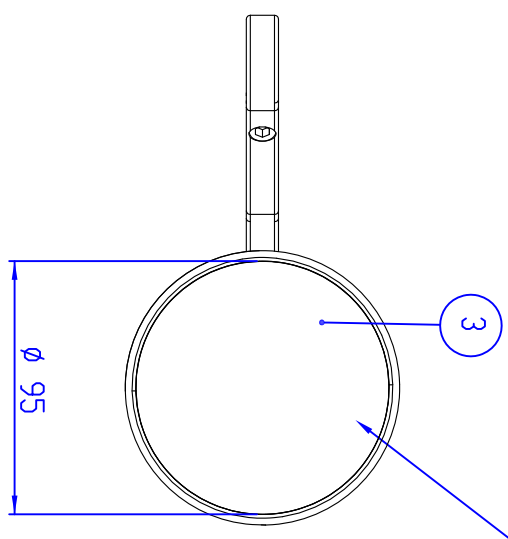

VARIANT B

TOL. UNLESS SPECIFIED		姓名	日期	表面處理 FINISH		DEPE 帝沛企業有限公司	
0 P/LC DEC. ± 0.30		審核		SIZE	(冊) REV	0	DEPE PRECISION-COMPONENTS
1 P/LC DEC. ± 0.15		APPV/D		A3	(圖) VER	0	P/W204
2 P/LC DEC. ± 0.05		主 管		材 質 MATERIAL:	比 例 SCALE:	1:1	DWG NO.
ANGULAR : ±1°		CHIEF		0			BOM NO.
ALL DIMENSIONS mm		審核一					UNIT NO.
		CHKD					機 型
		專 業 繪 圖 人					0
		MFG					
		繪 圖 者					
		DRAWN					
投 影 縮 小 率				061416		9	
投 影 內 容				重 量 WEIGHT:			
EON NO							
		更 改 者					
		NAME					
		日 期					
		DATE					

Item	Qty	Part Number	Material
1	1	Housing	Aluminum
2	1	Stem	Aluminum
3	1	Mirror	Glass
4	1	Bolt	Stainless

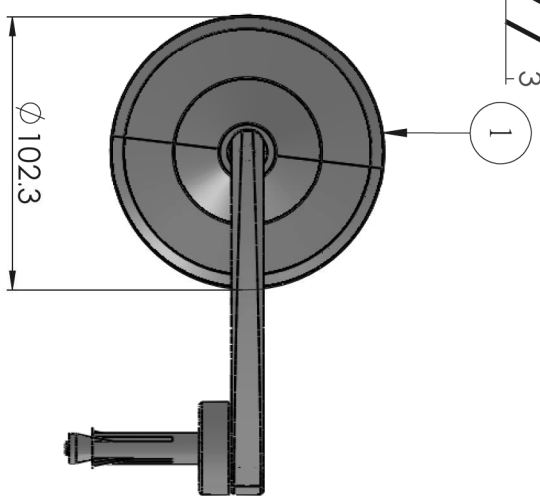
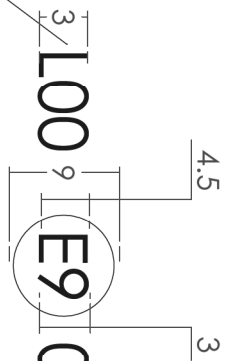
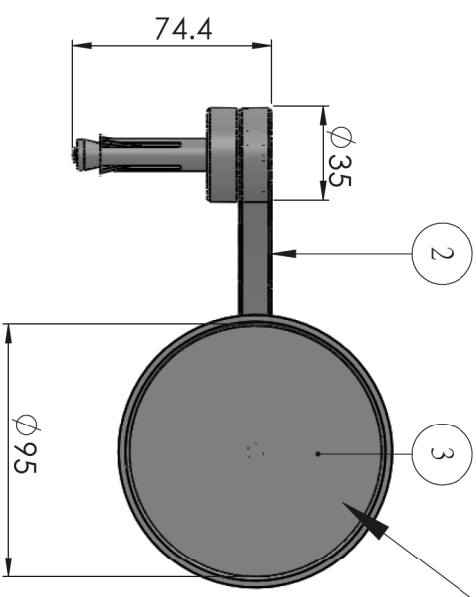
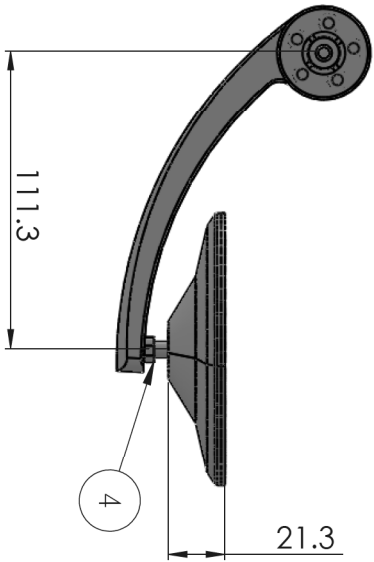

DEPE
L009 E9 001377 3

TOL UNLESS SPECIFIED 0 P/C DEC: ± 0.30 1 P/C DEC: ± 0.15 2 P/C DEC: ± 0.05 ANGULAR: ± 1°		ALL DIMENSIONS mm		第三角法	
校核 APPR'D	姓名 NAME	日期 DATE	表面處理 FINISH:	尺寸 SIZE	材料 MATERIAL:
主 CHIEF				(研) REV 0	帝沛企業有限公司 DEPE PRECISION-COMPONENTS
審查 CHKD			A3	(圖) VER 0	TITLE: DEPE 帝沛企業有限公司
專案負責人 MFG			比例 SCALE: 1:1	DWG NO.	pw204+evo 大手把
繪圖者 DRAWN			重量 WEIGHT: g	BOM NO.	機型 0
設備編號 ECON NO	設備內容 ECON	更改者 NAME	日期 DATE		

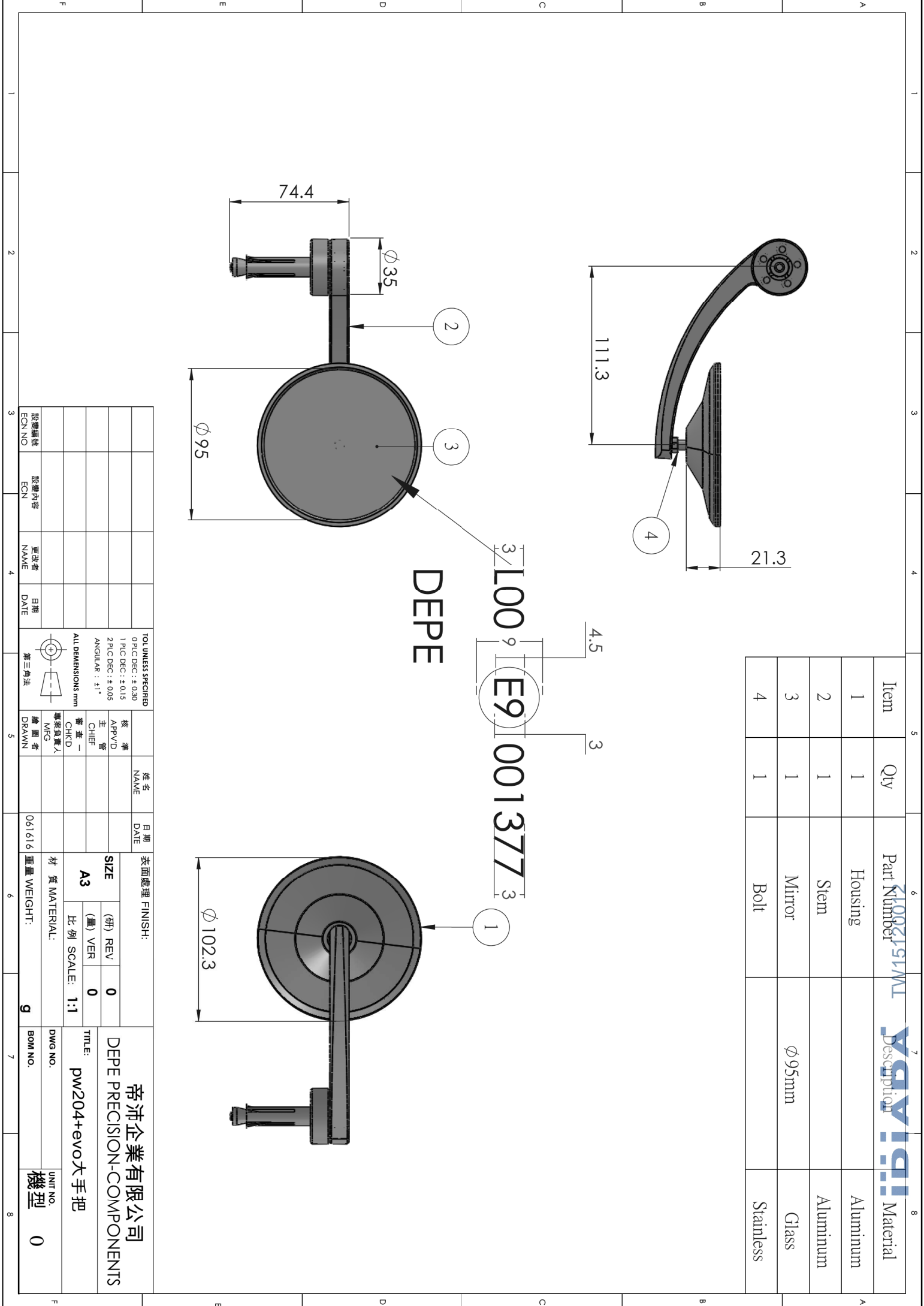

Item	Qty	Part Number	Description	Material
1	1	Arm v2		Aluminum 6061
2	1	BLDCK		Aluminum 6061
3	1	Screw M10		Stainless Steel
4	1	Bolt		Stainless Steel
5	1	Housing VI		Aluminum 6061
6	1	Mirror VI	∅ 95mm	Mirror
7	1	Block bolt		Stainless Steel

細部放大圖 F

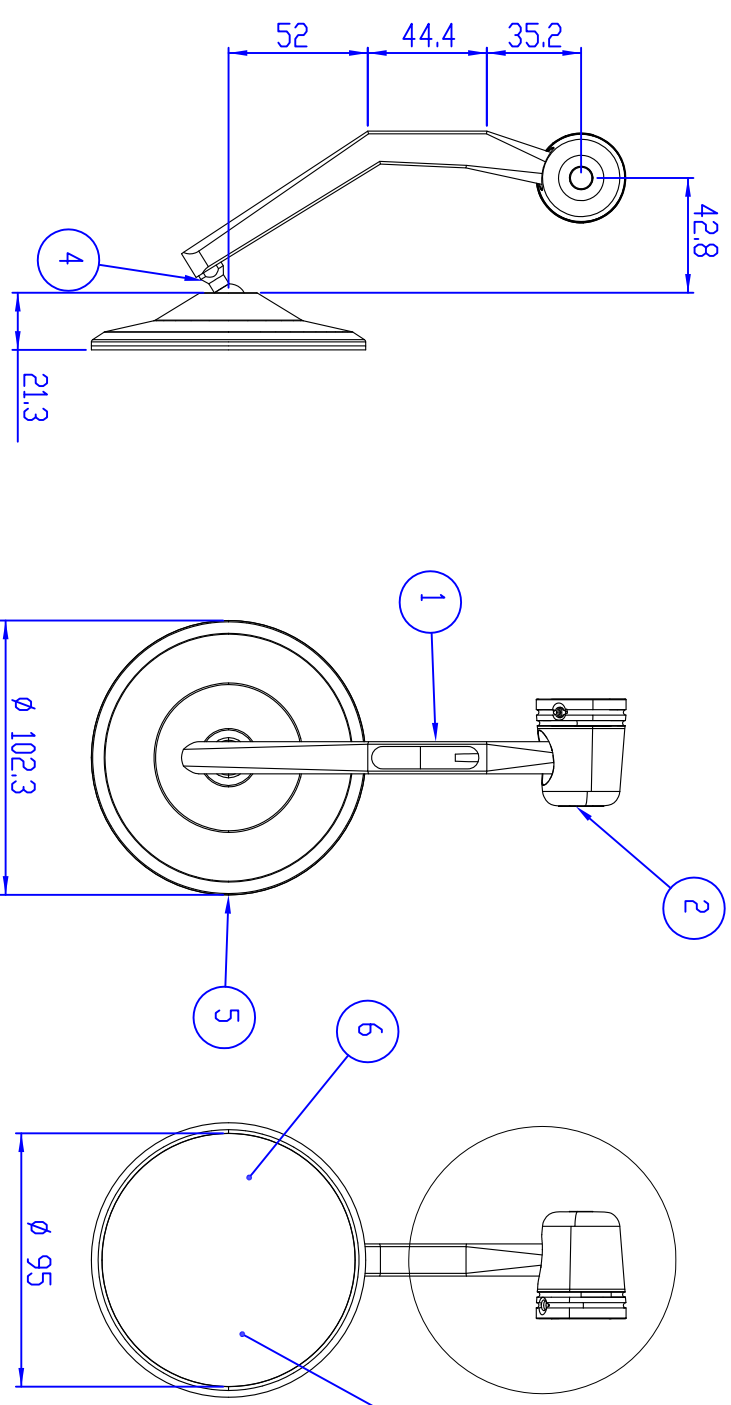
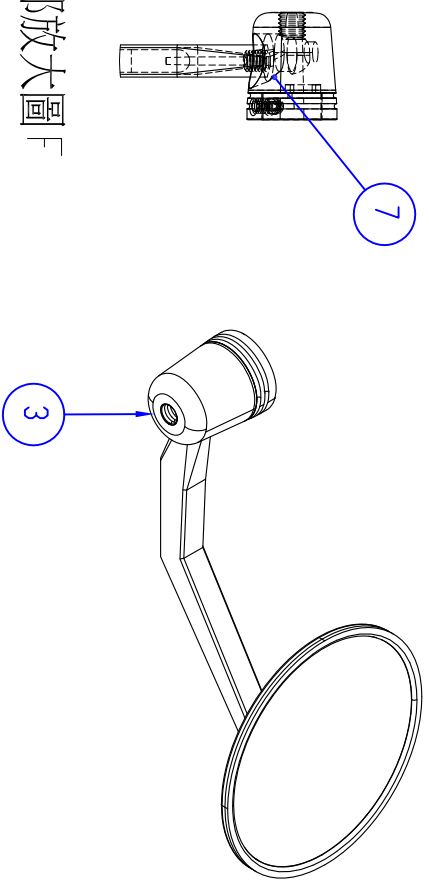

37.00 4.5 9 3
 DEPE
 0013773

VARIANT D

TOL. UNLESS SPECIFIED		姓名	日期	表面處理 FINISH	
0 P/LC DEC: ± 0.30		APPROV'D		SIZE	(冊) REV
1 P/LC DEC: ± 0.15		王 聖		A3	(圖) VER
2 P/LC DEC: ± 0.05		CHIEF		比例 SCALE:	0
ANGULAR : ±1°		審查一		0	1:1
ALL DIMENSIONS mm		CHK'D		材 質 MATERIAL:	
		MFG		重量 WEIGHT:	0
		專案負責人		DWG NO	
		繪圖者		BOM NO	
		DATE	061416	DWG NO	
		DATE		BOM NO	
		變更內容		UNIT NO.	機型
		變更編號			0
		ECN NO			

帝沛企業有限公司
 DEPE INTERNATIONAL CO.,LTD

TITLE: PW204

Item	Qty	Part Number	Description	Material
1	1		Housing	Aluminum
2	1		Stem	Aluminum
3	1		Mirror	Glass
4	1		Bolt	Stainless

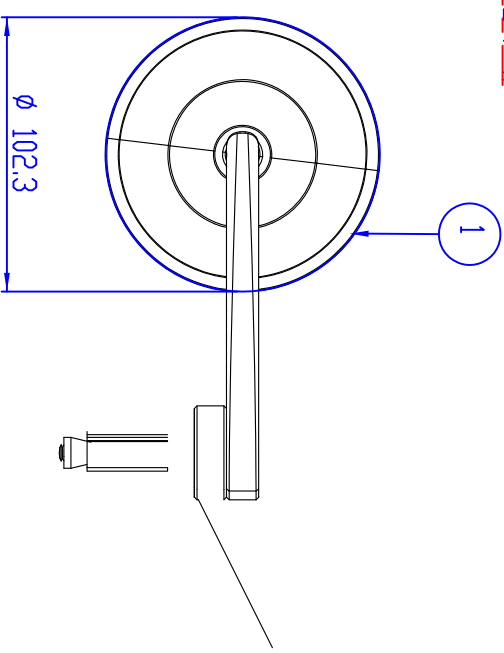
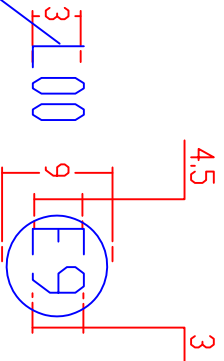
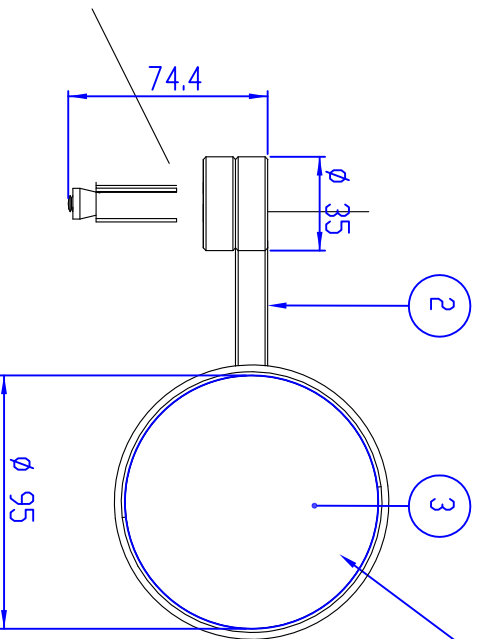
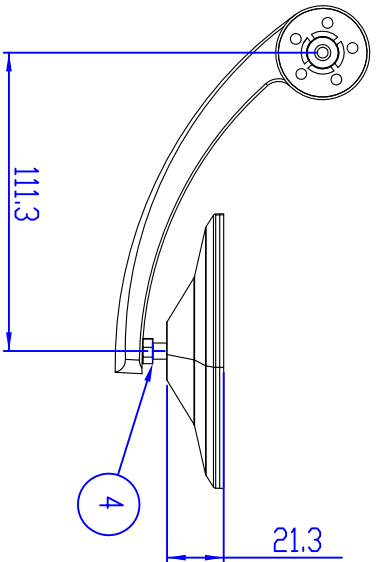

DEPE
 3100
 001373

VARIANT E

TOL. UNLESS SPECIFIED		姓名	日期	表面處理 FINISH		DEPE 帝沛企業有限公司	
0 P/LC DEC. ± 0.30	1 P/LC DEC. ± 0.15	APPV'D		SIZE	〈冊〉 REV	0	帝沛企業有限公司
2 P/LC DEC. ± 0.05	ANGULAR : ±1°	CHIEF		A3	〈圖〉 VER	0	PRECISION-COMPONENTS
ALL DIMENSIONS IN mm		CHK'D		材質 MATERIAL:	比例 SCALE:	1:1	TITLE: DEPE PW204
第三角法	第三角法	核准者 MFG	061616	重量 WEIGHT:	9	DWG NO.	機型
投標編號 EON NO	投標內容 EON	核准者 NAME	日期 DATE			BOM NO.	0