

# **12-INCH ELECTRIC MINI BIKE USER MANUAL**

**CHALLENGER 12 PLUS**

EL-MB07P | EL-MB07C

## **WARNING**

- Protective equipment should be worn. Not to be used in traffic.
- The user manual must be retained since it contains important information.
- The Mini Bike is intended to be assembled by adult.
- The screwdriver is only used by adults when assembling toys.

## **AVERTISSEMENT**

- Un équipement de protection doit être porté. Ne pas utiliser dans la circulation.
- Le manuel d'utilisation doit être conservé car il contient des informations importantes.
- Le Mini Bike est destiné à être assemblé par un adulte.
- Le tournevis n'est utilisé que par les adultes lors de l'assemblage de jouets.

## **WARNING**

- Es muss Schutzausrüstung getragen werden.
- Nicht im Straßenverkehr verwenden.
- Die Bedienungsanleitung muss unbedingt aufbewahrt werden, da sie wichtige Informationen enthält.
- Das Minibike ist für den Zusammenbau durch einen Erwachsenen vorgesehen.
- Der Schraubenzieher wird nur von Erwachsenen beim Zusammenbau von Spielzeug verwendet.

## **AVVERTIMENTO**

- È necessario indossare dispositivi di protezione. Da non utilizzare nel traffico.
- Il manuale utente deve essere conservato poiché contiene informazioni importanti.
- La Mini Bike è destinata ad essere assemblata da un adulto.
- Il cacciavite viene utilizzato solo dagli adulti durante il montaggio dei giocattoli.

## **ADVERTENCIA**

- Equipo de protección debe ser usado. No debe utilizarse en el tráfico.
- El manual del usuario debe conservarse ya que contiene información importante.
- La Mini Bike está diseñada para que la monte un adulto.
- El destornillador solo lo utilizan adultos para montar juguetes.

# CONTENTS

English .....	02-20
Français .....	21-39
Deutsch .....	40-58
Italiano .....	59-77
Español .....	78-96

# THANK YOU!

## FOR CHOOSING OUR MINI BIKE!

### BEFORE USING

Read and understand the user manual and all the other safety instructions and warnings before using the Mini Bike.

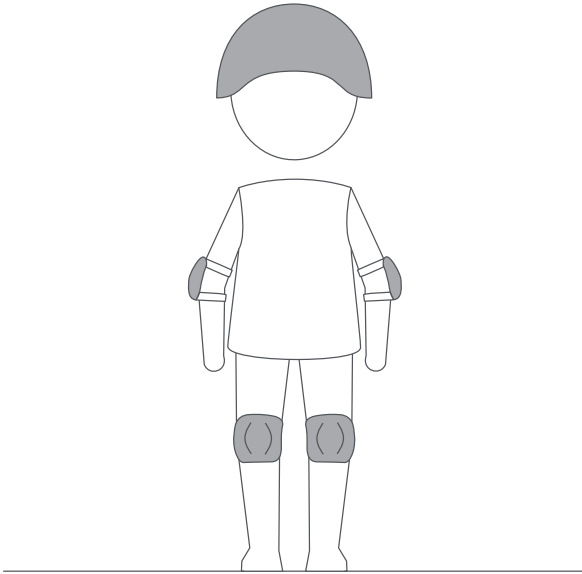

**7+ YRS.**











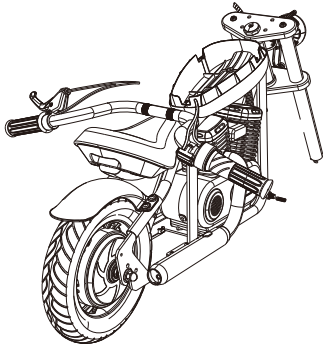

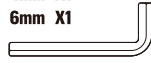
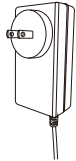
### **WARNING**

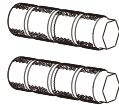
Allowing children under the age of 7 to operate this mini bike raises the likelihood of severe injury or even death.

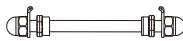
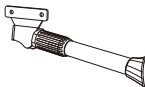
Adult supervision is required for children under the age of 12.

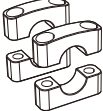
Do not allow children under the age of 7 to operate this Mini Bike.

# WHAT'S IN THE BOX

 <p><b>SEMI-ASSEMBLED MINI BIKE X1</b></p>	 <p><b>16mm X2</b></p>  <p><b>4mm X1</b> <b>6mm X1</b></p>	 <p><b>CHARGER X1</b></p>	
	 <p><b>USER MANUAL X1</b></p>	 <p><b>PEDAL X2</b></p>	
 <p><b>WHEEL X1</b></p> <p><b>WHEEL HARDWARE</b></p>  <p><b>AXLE WITH NUTS X1</b></p>	 <p><b>KICKSTAND X1</b></p> <p><b>KICKSTAND HARDWARE</b></p>  <p><b>BOLT X2</b></p>	 <p><b>HANDLEBAR CLAMP X4</b></p> <p><b>HANDLEBAR HARDWARE</b></p>  <p><b>MEDIUM BOLT X4</b></p>	 <p><b>STORAGE BOX LID X1</b></p>  <p><b>FENDER X1</b></p>

**THE PICTURES IN THE MANUAL ARE JUST FOR REFERENCE.  
PLEASE REFER TO THE ACTUAL PRODUCT FOR ACCURACY.**

# SAFE RIDING

- Before allowing children to use this mini-bike, adults must thoroughly assess the driving area and the child's ability to safely operate the bike. It is very important that children are taught the appropriate safety rules before they are allowed to ride the mini bike. In addition, these rules should be reviewed with any other children who wish to operate the Mini Bike.
- Remain seated. A child who is not sitting on the seat when the Mini Bike is in motion could fall or cause the Mini Bike to tip over.
- Do not operate the Mini Bike at night.
- Do not operate the Mini Bike near steep inclines as it can cause the following:
  - Unsafe speed, even if the throttle is released.
  - Tipping
  - Loss of traction, causing the Mini Bike to slip.
  - Rolling backwards at an unsafe speed.
- Avoid contact with moving/rotating parts, such as the motor brake, axle, and wheels. Contact with these parts can cause serious injury.
- Do not operate the Mini Bike when it's positioned on its side or upside-down.
- Do not operate the Mini Bike near flammable vapors (gasoline, paint thinner, acetone, liquid wax, etc.) as the electrical switch emits an internal spark, which could cause an explosion or fire.
- You should not ride if you are under the influence of alcohol or drugs, if you have a heart condition, are pregnant, have head, back, or neck ailments which limit your ability to ride safely, if you have any mental or physical conditions that may make you susceptible to injury or impair your physical dexterity or mental capabilities to recognize, understand, and perform all of the safety instructions and to be able to assume the hazards inherent with the product.
- Before each use, conduct a basic safety inspection including: (i) condition of tires; (ii) safe operation of brakes and lights; (iii) good condition of the frame; (iv) sufficient battery charge; and (v) any sign of damage, unusual or excessive wear, or other open and obvious mechanical problem/maintenance needs. Components shall be maintained and repaired in accordance with the manufacturer's specifications. Only the manufacturer's authorized replacement parts should be used to service your product.
- Only use on private property. Do not use on public property, streets, or sidewalks. Grass, dirt or other soft terrain are recommended.
- Do not ride aggressively, perform jumps, or take sharp turns. Aggressive riding may damage the product and increase risks.
- Do not carry or tow other products behind the Mini Bike for kids.
- Do not use for racing, stunt riding, or other aggressive maneuvers. These types of riding may result in damage to the product and decrease rider control, resulting in injury.



## **WARNING**

### **TO AVOID SERIOUS INJURY:**

- Continuous adult supervision is required.
- Never use on roadways, steep inclines or steps, swimming pools, or other bodies of water.
- Never allow more than one rider.
- Riders should always be seated.
- Always wear shoes. Ensure shoes are tied and laces away from the drive and wheels.
- Maximum weight: 144.0 lbs. (65.0 kgs).
- Periodically check hardware and tighten it if necessary. Replace worn or broken parts immediately.
- Never use or store in wet conditions.
- For use in large open areas. Avoid collisions.
- Skill is required to avoid falls or collisions.
- Never ride at night.
- Only use the battery specified by the manufacturer.
- Only use the charger specified by the manufacturer.
- Riding the Mini Bike for Kids presents potential risks, and caution is required when riding. Inherent hazards are associated with its use (for example, falling off or riding it into a hazardous situation). Adult Supervision is needed, and adults must recognize that a rider can be seriously injured or die, even when safety precautions are taken. RIDE AT YOUR OWN RISK. Children under six years are prohibited from using this product.
- A child must have the required skill level and maturity to ride this product safely. Not all 6-year-olds are equipped to ride the product. Ensure that the rider's physical size, age, weight, maturity, and ability to follow the rules are sufficient before letting your child ride.
- Risk of injury or death from loss of control, collisions, and falls. Always wear a properly fitted helmet and other protective equipment, such as elbow pads and knee pads, as this may be required by local law.
- Always keep two hands on the handlebars at all times.
- Do not touch the brake or motor housing after use. These components may be hot.
- Protective equipment should be worn. Not to be used in traffic.
- Riding on public transportation roads is not allowed.
- This toy is unsuitable for children under 6 years of age due to its maximum speed.
- This toy contains a battery that is non-replaceable.
- Never use on roadways, near motor vehicles, on or near steep inclines or steps, swimming pools or other bodies of water. Always wear shoes, and never allow more than 1 rider.

# ASSEMBLY

ADULTS MUST ASSIST CHILDREN WITH THE ASSEMBLY AND INITIAL ADJUSTMENT PROCEDURES OF THE PRODUCT.

The diagram consists of four panels, A, B, C, and D, illustrating the front wheel assembly process. Panel A shows a wheel with a red arrow pointing to the axle and a label 'INSERT'. Panel B shows a close-up of the axle being tightened with a label 'TIGHTEN'. Panel C shows the wheel being mounted onto the front fork, with a red outline for the wheel and a label 'C'. Panel D shows the wheel fully assembled on the fork, with a label 'TIGHTEN' and a callout box showing a close-up of the axle nut being tightened.

**A**

INSERT

ALIGN THE INNER BEARING SLEEVE BEFORE INSTALLING WHEELS.

**B**

TIGHTEN

**C**

**D**

TIGHTEN

**FRONT WHEEL ASSEMBLY**

NOTE: BE CAREFUL WHEN INSTALLING THE FRONT WHEEL DUE TO SHARP POINTS ON THE FRONT FORK.

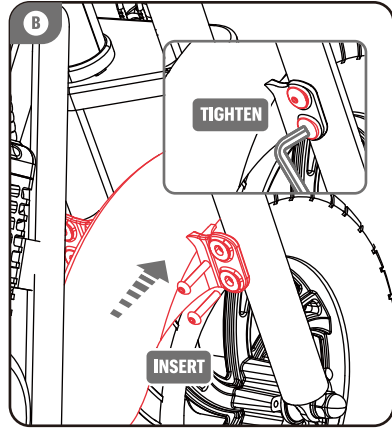
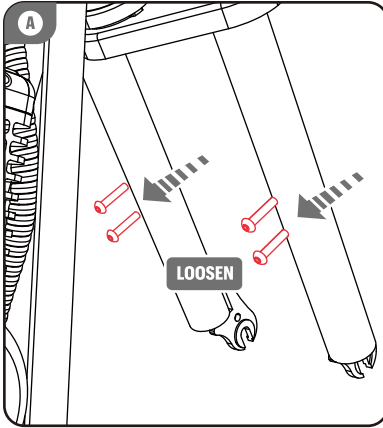

### MUDGUARD ASSEMBLY

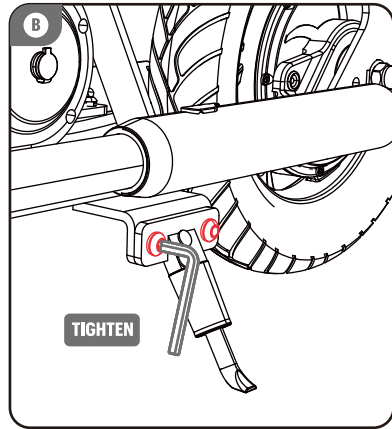
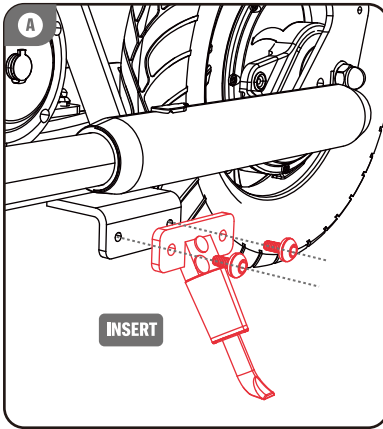

### KICKSTAND ASSEMBLY

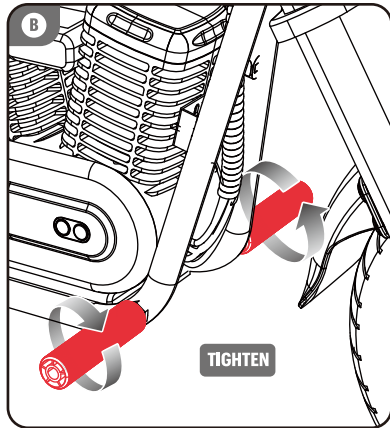
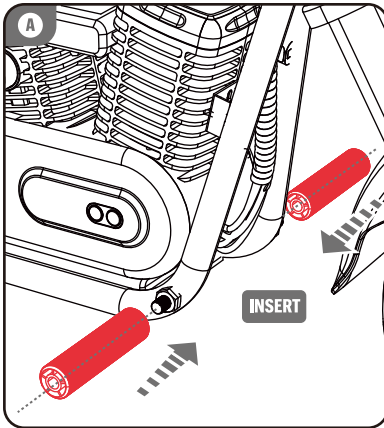

### PEDAL ASSEMBLY

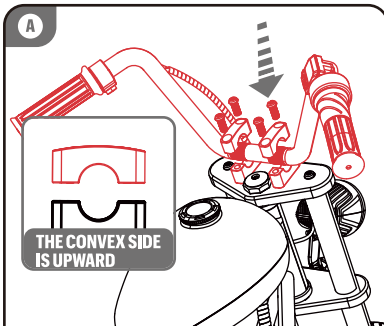

PLACE HANDLEBARS IN HANDLEBAR CLAMP IN AN UPRIGHT, VERTICAL POSITION. INSERT BOLTS AND TIGHTEN SECURELY.

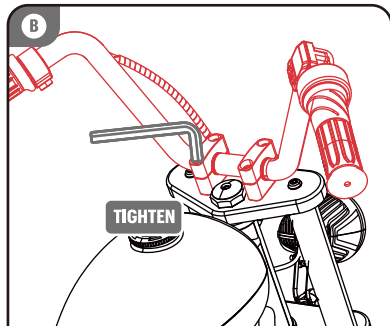

WHEN PROPERLY TIGHTENED, THE HANDLEBARS SHOULD NOT MOVE FORWARD OR BACKWARD.

### HANDLEBAR ASSEMBLY

NOTE: TAKE CARE WHEN INSTALLING HANDLEBARS, AVOID PINCHING THROTTLE AND BRAKE WIRES.

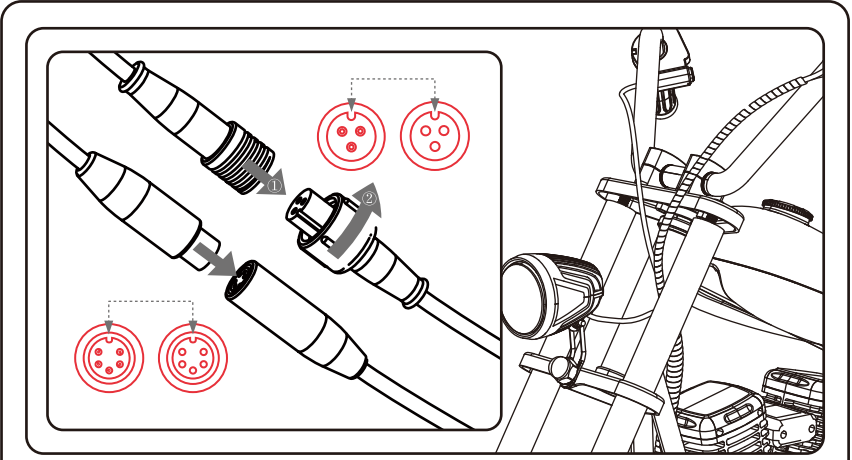

**CONNECT THE CABLES**

PLEASE MAKE SURE ALL THE CABLES ARE CONNECTED CORRECTLY.  
TAKE THE ABOVE PICTURES AS REFERENCE.

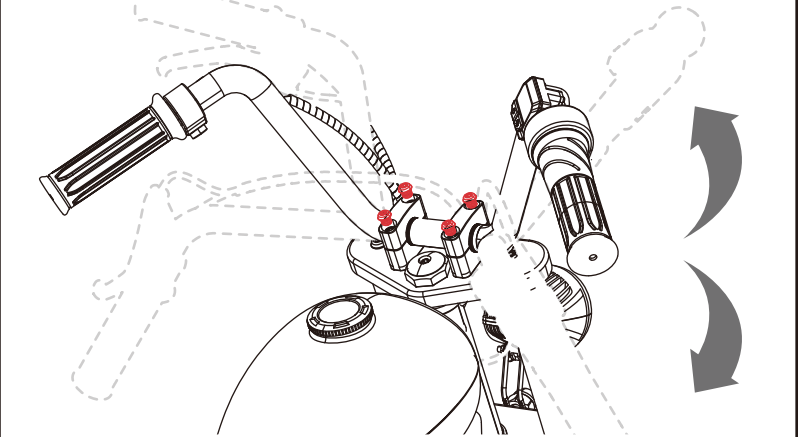

NOTE: PLEASE RELEASE THE SCREWS OR BOLTS BEFORE ADJUSTING THE HANDLEBARS.  
WHEN PROPERLY TIGHTENED, THE HANDLEBARS SHOULD NOT MOVE FORWARD OR BACKWARD.

**HANDLEBAR ADJUSTMENT**

ADJUSTABLE HANDLEBARS, CAN BE ADJUSTED TO THE COMFORTABLE POSITION.

# OVERVIEW

The Mini Bike is a toy, it is not intended for transportation. In order to master riding skills, the rider needs to practice.

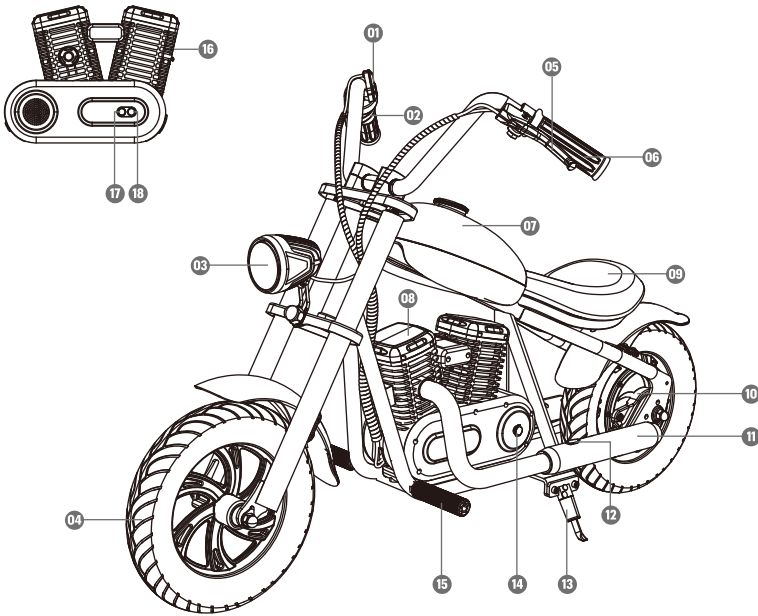

- |                |                           |                        |
|----------------|---------------------------|------------------------|
| 01 DISPLAY     | 07 STORAGE BOX            | 13 KICKSTAND           |
| 02 THROTTLE    | 08 BATTERY                | 14 CHARGING PORT       |
| 03 HEADLIGHT   | 09 SEAT                   | 15 PEDAL               |
| 04 FRONT WHEEL | 10 MOTOR                  | 16 SMART LED LIGHT     |
| 05 BRAKE       | 11 SIMULATED EXHAUST PIPE | 17 ENGINE SOUND SWITCH |
| 06 HANDLEBAR   | 12 WATER FILLING PORT     | 18 STEAM SWITCH        |

# THROTTLE INSTRUCTION

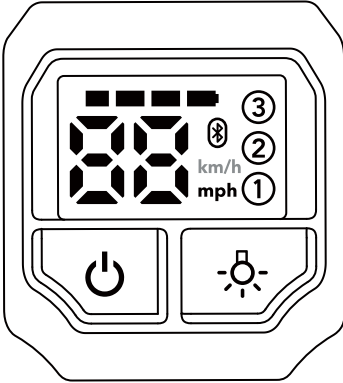

## BATTERY LEVEL

This icon indicates the battery remaining.

## SPEED DISPLAY

This icon indicates the current speed in mph.  
\* Press POWER ON/OFF button 2 times shortly, swift the unit of mph to km/h.

## BLUETOOTH

This icon will only appear after APP is successfully connected.

## SPEED DISPLAY

This icon indicates the current speed mode.

①: 5mph / ②: 8mph / ③: 10mph

## ON/OFF BUTTON

Press and hold for 2 seconds to turn on or off.  
Short press to adjust the max speed.

## AMBIENT LIGHT BUTTON

Press for 2 seconds to turn on or off the headlight.  
Press twice quickly to turn on or off the atmosphere light.  
Press once quickly to switch the lighting effects.

# CHARGE YOUR MOTORBIKE

Please charge your Mini Bike before using.

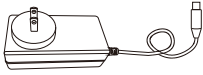

Make sure the Mini Bike is in Power Off status while charging.

**NOTE:** Battery and charger are included. Battery must be fully charged before use. Only use our battery and charger for this product.

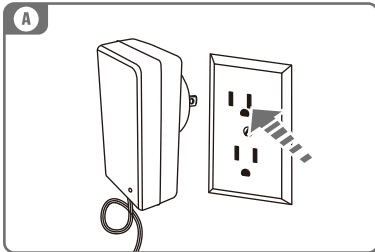

Plug the charger plug into the wall outlet. The light on the charger should be green. Note: Try a different outlet if the green light (LED) does not turn on.

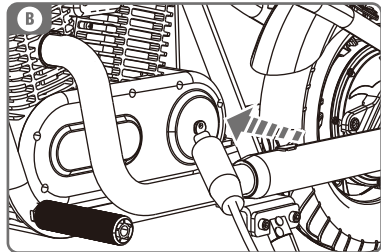

Open the charging port cover, plug in and charge. The light on the charger will be red during charging and turns green after a full charge.



## WARNING

This product uses rechargeable Lithium batteries. Improper use may cause serious injury or death. Do not charge the product indoor or during sleep.

## **WARNING**

Please read all instructions and cautionary markings on the charger and the Mini Bike before use.

Note: The battery pack is not fully charged when you first receive it. Before charging, read the safety instructions and follow the proper charging procedures.

- Only use the specified 24V charger to charge this Mini Bike. Do not attempt to charge it with any other charger.
- Do not store the Mini Bike in locations where the temperature is below 32°F (0°C) or above 122°F (50°C).
- Do not charge the Mini Bike in temperatures below 14°F (-10°C) or above 122°F (50°C) as it can cause damage to the battery pack.
- Do not operate the charger if it has been impacted, dropped, or damaged in any way. Before each use, examine the charger and replace it if you find any wear or damage.
- The charger is designed to operate on standard household electrical power (100/240V). Do not attempt to use the charger with any other voltage level.
- Never modify the electrical system as it may result in the risk of electric shock, electrocution, or fire.
- During charging, the Mini Bike must be placed in a dry and well-ventilated area.
- To avoid damage to the charger, always pull from the plug rather than the cord when removing it from an outlet.
- Make sure the cord is positioned in a way that it won't be stepped on, tripped over, or subjected to damage or stress.
- An extension cord should only be used if absolutely necessary. The use of an improper extension cord could result in the risk of fire, electric shock, or electrocution.
- To prevent electric shock, do not immerse the charger in water when cleaning. To clean, first remove the charger plug from the outlet and wipe it with a dry cloth.
- Do not place any objects on top of the charger or place the charger on a soft surface that may cause excessive heat. Keep the charger away from any heat sources.

## PREPARATION

- Always wear proper protective equipment, such as an approved safety helmet (with chin strap securely buckled), elbow pads, and knee pads.
- A helmet may be legally required by local law or regulation in your area.
- Always wear shoes and keep shoelaces tied and out of the way of the wheels and motor. Never ride barefooted or in sandals.



## SWITCH ON/ OFF

- **Turn On:** Press the button for 2 seconds; there will be a ring after turning on.
- **Turn Off:** Press the button for 2 seconds; after “Power off” rings, it turns off.

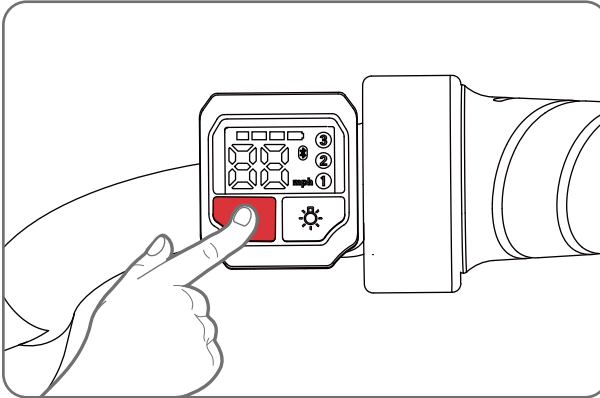

## STARTING THE MINI BIKE

To start the Mini Bike, sit on the Mini Bike and turn on the power switch. Place both hands on the handlebars and apply the throttle with your right hand.

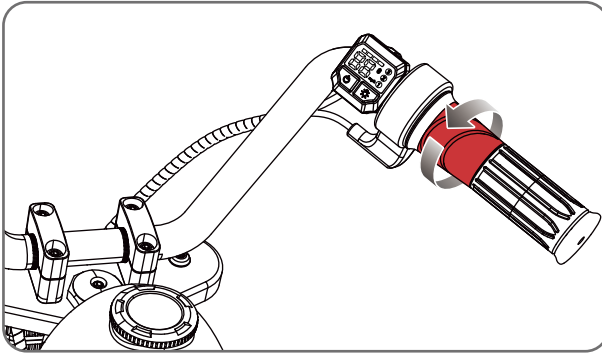

## STOPPING THE MINI BIKE

To stop the unit, release the throttle and apply the brakes until the Mini Bike comes to a complete stop.

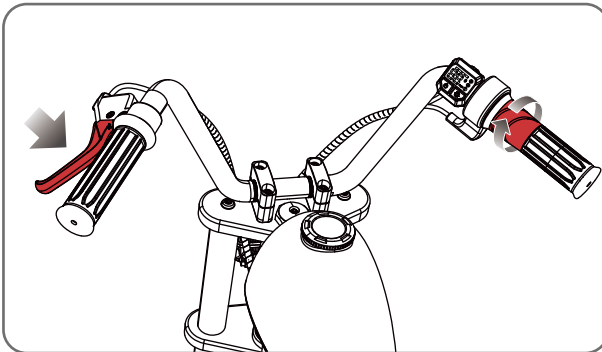

## SWITCHING GEARS

The design has three gears, with the default starting gear being toddler mode (①). Simply press the shift button to change gears easily.

The speed can be changed by turning the handle.

① **LOW 5MPH**    ② **MID 8MPH**    ③ **MAX 10MPH**

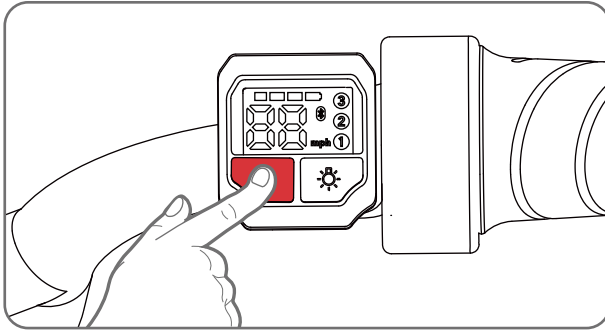

## LED LIGHTS

Light-up design on the Mini Bike.

There are two kinds of lights on Mini Bike: light-up on Mini Bike & Luminosity spotlight.

When the Mini Bike turns on, the lights will all be on.

- Press and hold the light button for 2 seconds to turn or off the headlight.
- Press the light button twice quickly to turn on or turn off the atmosphere light.
- Press the light button for 1 time quickly to switch the lighting effects, with the order of switching being **rainbow flow**, **rainbow breath**, **green**, **purple**, and **red**.

**THE APP CAN BE USED TO TURN ON/OFF AND SWITCH THE LIGHTS.**

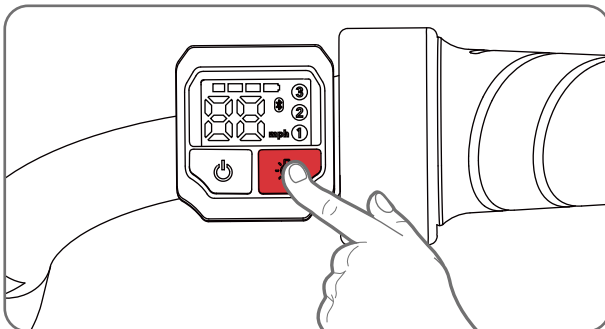

## ENGINE SOUND OPERATION

By the default setting, the engine sound is enabled when the bike is started. Press the switch button once to turn it on / off. Can only use the switch button to operate it. Can't use APP to change the status of engine sound function.

**NOTE:** When playing music via Bluetooth, the engine sound will be muted and only the music will play.

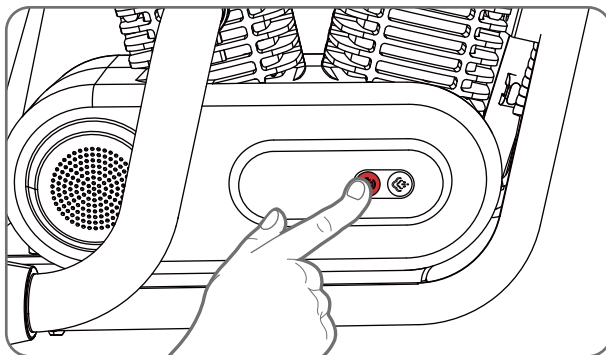

## SIMULATED EXHAUST PIPE OPERATION



The default setting for this function upon motorbike startup is "off".

**Switch On:** Open the cap of water filling port, add an appropriate amount of water, then press the switch button.

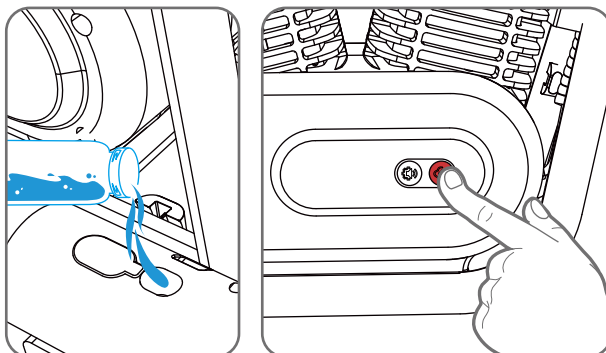
**Switch Off:** Press the switch button once.



# SPECIFICATIONS

MODEL	EL-MB07C	EL-MB07P
IMAGE		
PRODUCT DIMS (INCH)	L45.3 X W19.6 X H28.5	L45.3 X W19.6 X H28.5
N. W (LBS)	35.1	35.1
BATTERY TYPE	LI-ION 21.9V 98.28WH	LI-ION 21.9V 98.28WH
INPUT	DC 24V/1.5A	DC 24V/1.5A
MOTOR	24V 160W	24V 160W
MAX. LOAD (LBS)	144.0	144.0
MAX. SPEED (MPH)	10.0	10.0
TORQUE (N.M)	11.0	11.0
MAX. RANGE (MILES)	8.0	8.0
SPEED MODE	3 LEVELS	3 LEVELS
CHARGE TIME	4 HOURS	4 HOURS
TIRES (INCH)	12.0*3.0	12.0*3.0
HEADLIGHT	✓	✓
DISPLAY	✓	✓
FENDER	✓	✓
APP	✓	-
LED LIGHT	✓	✓
SMOKE	✓	✓
SPEAKER	✓	✓

# PAIRING YOUR BLUETOOTH DEVICE

- Ensure both the Bluetooth® function in your device and the Mini Bike are turned on.
- Open the Mini Bike APP on your device to connect wirelessly to the Mini Bike.
- On your device, locate the Bluetooth® device list. Select “Hypergogo” from the list.

## APP

Play your Music/Customize LED Lights/3 Speed Modes

- Change the light modes via APP;
- Change the Mini Bike working modes by APP.
- Can set any speed in the set-up working mode scope.
  - Kids mode: Max. 5 MPH
  - Normal mode: Max. 8 MPH
  - Sports mode: Max. 10 MPH



# MAINTENANCE & REPAIR



## WARNING

### MAINTENANCE INSTRUCTIONS:

- It is the responsibility of the adult who assembles this product to properly install all parts included in the carton. These instructions are valuable.
- Check nuts and bolts often and tighten if necessary.
- Any parts showing evidence of wear should be replaced immediately.
- Check all screws and their protective coverings regularly and tighten as required. Check plastic parts on a regular basis for cracks or broken pieces.
- During snowy or rainy weather, the Mini Bike should be stored inside.
- Do not operate the Mini Bike in wet or snowy conditions.
- Do not clean the Mini Bike by spraying with a hose. Water or moisture in the motors, battery, or electrical components can cause component failure.
- To clean the Mini Bike use a dry cloth. A non-wax furniture polish can be used to clean plastic parts. Do not spray the Mini Bike with a hose or submerge in water.
- Check tire pressure prior to riding. Air may slowly escape if the inner tube has been damaged or punctured, patch or replace the tube if pressure is routinely low prior to riding.
- Inspect tires for wear and tear periodically, the tire tread will wear over time during normal use. Replace the tire once the wear is excessive or impacts product performance.
- Before riding, check the frame and handlebars for cracks or broken connection points. Aggressive riding or crashing into objects may damage or destroy the frame or handlebars. Thoroughly inspect the frame, handlebars, and hardware after any incident and before every ride.

### SPECIAL ATTENTION INDICATORS

HEADLIGHT LED	ERROR
<b>E 0</b>	<b>Communication failure (the instrument cannot receive data)</b>
<b>E 1</b>	<b>Handlebar failure</b>
<b>E 2</b>	<b>Brake Lever Malfunction</b>
<b>E 3</b>	<b>Hall Sensor Error</b>
<b>E 4</b>	<b>MOS malfunction</b>
<b>E 5</b>	<b>Mainboard Malfunction</b>
<b>E 6</b>	<b>Battery failure</b>