



LP0184

**FITTING INSTRUCTIONS FOR LP0184BK LICENCE PLATE BRACKET**  
**SUZUKI GSX-S 1000 2015-**

Page | 1



**THIS KIT CONTAINS THE ITEMS PICTURED AND LABELLED BELOW.**  
**DO NOT PROCEED UNTIL YOU ARE SURE ALL PARTS ARE PRESENT.**

**Please note that the way the kit is packed does not necessarily represent the way of mounting to the bike**

THE PARTS SHOWN MAY BE REPRESENTATIVE ONLY (FOR CLARITY OF INSTRUCTIONS ONLY)

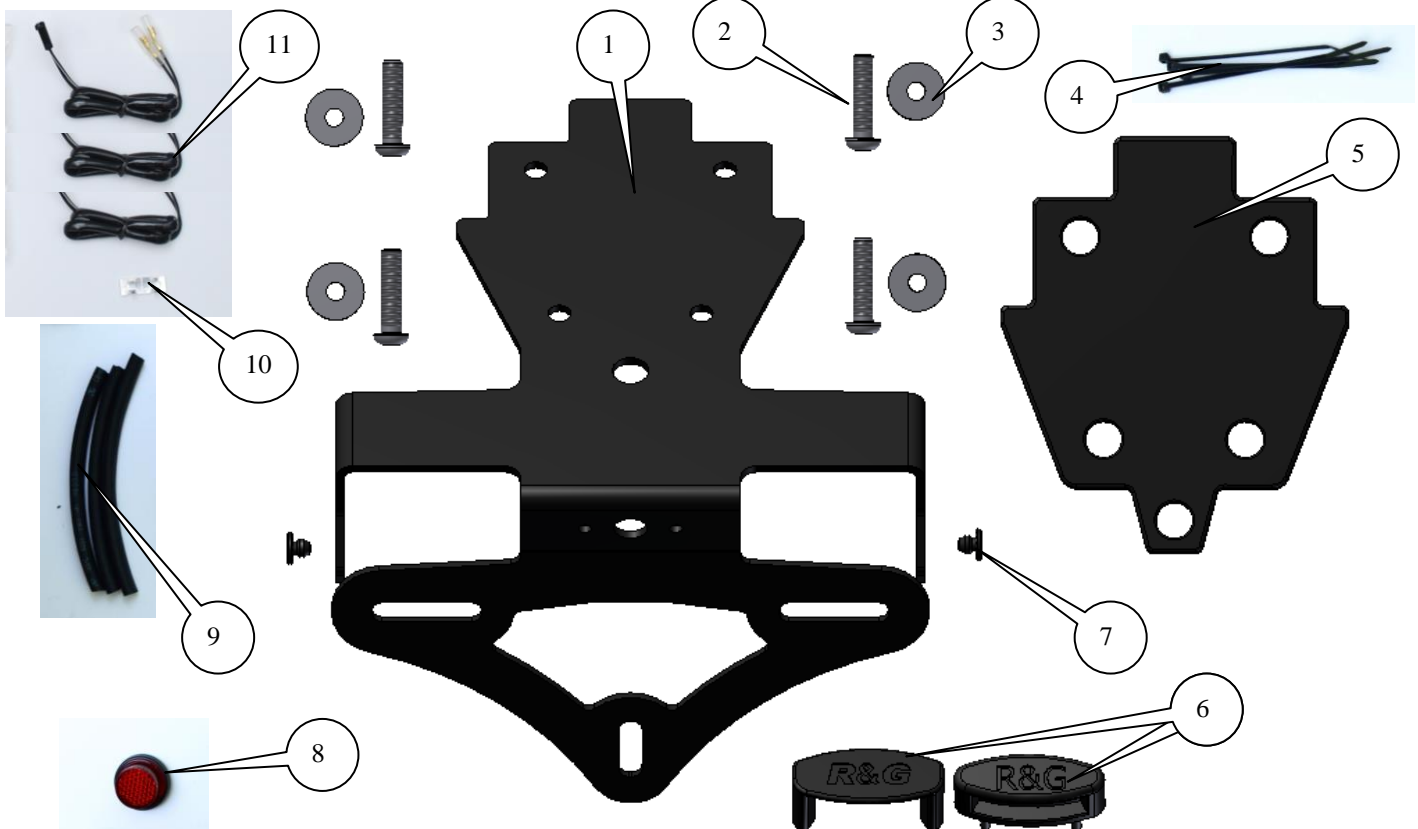

R&G Racing

Unit 1, Shelley's Lane, East Worldham, Alton, Hampshire, GU34 3AQ

Tel: +44 (0)1420 89007 Fax: +44 (0)1420 87301 [www.rg-racing.com](http://www.rg-racing.com) Email: [info@rg-racing.com](mailto:info@rg-racing.com)



LP0184

### **LEGEND**

ITEM 1 = LICENCE PLATE MOUNTING BRACKET (TB0184BK) (x1).

ITEM 2 = M6x25mm BUTTON HEAD BOLTS (x4).

Page | 2

ITEM 3 = M6 WASHERS (16mm O/DIA) (x4).

ITEM 4 = CABLE TIES LONG (x4).

ITEM 5 = SHAPED UNDER-TRAY SPACER (S0895) (x1).

ITEM 6 = LICENCE PLATE ILLUMINATOR ASSEMBLY (LA0002) (x1).

ITEM 7 = RUBBER GROMMETS (RB50-20-00FG) (x2).

ITEM 8 = REFLECTOR (REFL 1) (x1).

ITEM 9 = 150mm LENGTHS OF HEAT SHRINK (x3).

ITEM 10 = SELF ADHESIVE CABLE CLIPS (x2).

ITEM 11 = INDICATOR AND LICENCE PLATE ILLUMINATOR CONNECTORS (CON0006)  
(x2).

Please note that in cases where kits are packed with rubber washers holding the components onto the bolt – *the rubber washers should be thrown away!*

### **TOOLS REQUIRED**

- Set of metric Allen keys to include 4 and 5mm A/F.
  - 10mm Socket and wrench.
  - 8mm Spanner.
  - Phillips driver.
- Small amount of super glue.



PICTURE 1

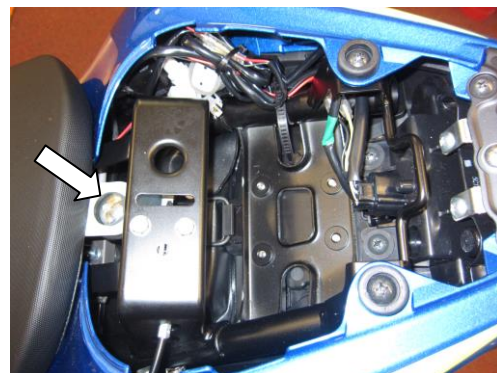

PICTURE 2



LP0184



PICTURE 3

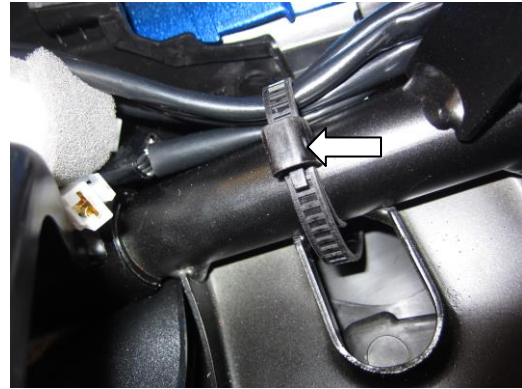

PICTURE 4

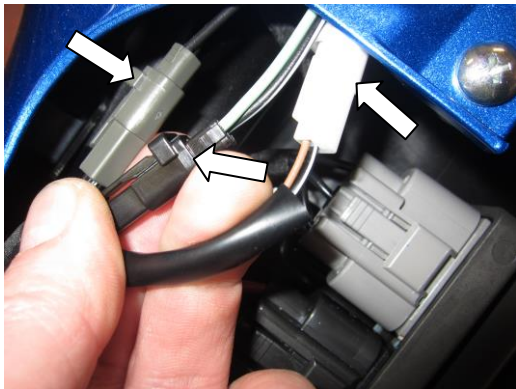

PICTURE 5

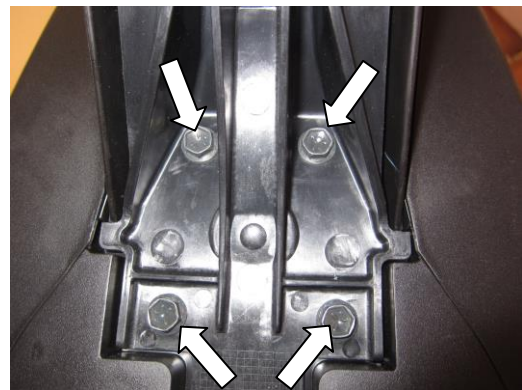

PICTURE 6



PICTURE 7

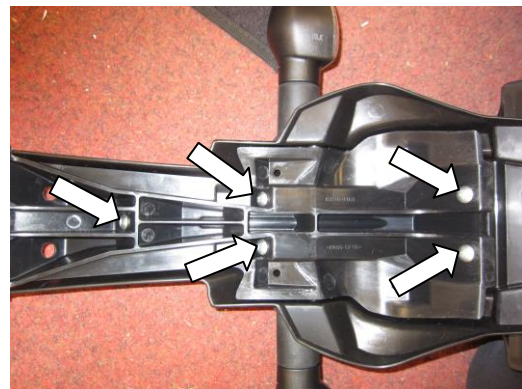

PICTURE 8



LP0184

Page | 4

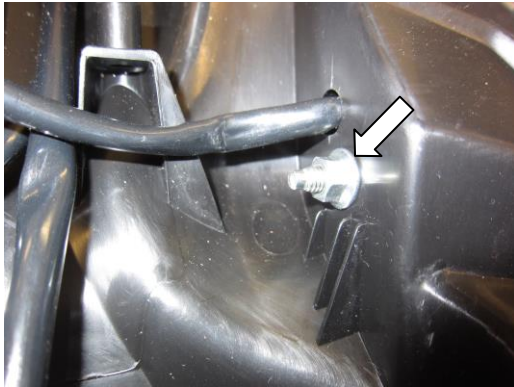

PICTURE 9



PICTURE 10



PICTURE 11



PICTURE 12

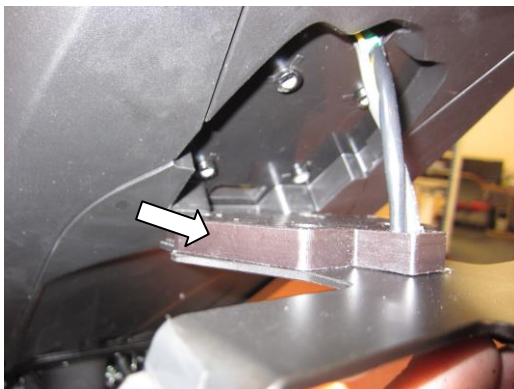

PICTURE 13

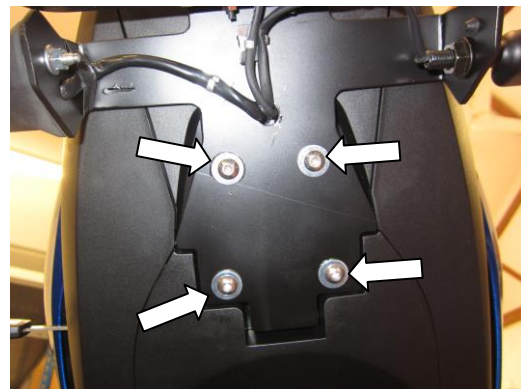

PICTURE 14



LP0184

Page | 5



PICTURE 15



PICTURE 16

### FITTING INSTRUCTIONS

- Remove the pillion seat using the key as shown in picture 1.
- Remove the bolt arrowed in picture 2 and remove the rider seat.
- Please take note of the wiring route as shown in picture 3.
- Unclip the wiring tie arrowed in picture 4.
- Disconnect the indicator and licence plate illuminator wiring plug sockets arrowed in picture 5.
- Remove the four bolts arrowed in picture 6, and gently remove the original licence plate bracket whilst being care to avoid snagging the wiring as shown in picture 7.

#### If using the original indicators

- Remove the five screws arrowed in picture 8 and remove the cable cover.
- Undo and remove the nut arrowed in picture 9 and remove the indicator as shown in picture 10.
- Repeat for the other indicator.
- Fit the original indicators to the new licence plate bracket (item 1) using the original nut as shown in picture 11.

#### If fitting R&G mini indicators (R&G product code RG370=bulb, RG371=LED or RG372 = Aero LED

- If fitting the R&G Mini Indicators, they will fit into the rear hole in the new licence plate bracket (item 1), we have supplied two rubber grommets (item 7) to blank off the remaining holes. Using the supplied connectors (item 11) it is a good idea to connect into the loom to check operation at this stage (if illumination fails, swap the bullet connections around). (Please use the heat-shrink (item 9) to protect the new indicator wires).
- Fit the new licence plate illuminator (item 6) to the licence plate bracket assembly as shown in picture 12 (please use the provided heat shrink (item 9) to protect the wiring).
- **PLEASE NOTE YOU WILL NEED TO GLUE THE LIGHT SHROUD TO THE LED LICENCE PLATE ILLUMINATOR USING A SMALL AMOUNT OF SUPER GLUE.**
- Feed the wiring through the larger central hole in the new licence plate bracket.
- Place the shaped spacer (item 5) onto the new licence plate bracket and feed the wiring through the larger central hole in the spacer as shown in picture 13.
- Offer the assembly into position while feed the wiring through the hole in the under-tray as original, shown in picture 13.
- Using the four M6 button head bolts and washers (items 2 and 3) through the four holes in the new licence plate bracket and spacer from underneath and into the threaded holes in the sub frame as original (shown in picture 14) and secure.

R&G Racing

Unit 1, Shelley's Lane, East Worldham, Alton, Hampshire, GU34 3AQ

Tel: +44 (0)1420 89007 Fax: +44 (0)1420 87301 [www.rg-racing.com](http://www.rg-racing.com) Email: [info@rg-racing.com](mailto:info@rg-racing.com)



LP0184

Page | 6

- If fitting original indicators reconnect the two indicator wiring plug sockets as original and check operation.
- If fitting R&G Mini indicators use the supplied connectors (item 11) to reconnect the indicators and check operation (if illumination fails, swap the bullet connections around).
- Connect the licence plate illuminator using the supplied connector (item 11) (if illumination fails, swap the bullet connections around).
- Use the cable clips and cable ties (items 4 and 10) to tidy the wiring.
- Fit licence plate to new licence plate bracket (it may require re-drilling).
- **IMPORTANT: IF FITTING A FULL-SIZE LICENCE PLATE AND PLACING IT FAR DOWN ON THE LICENCE PLATE HANGER, THERE IS A SMALL CHANCE OF THE LICENCE PLATE HITTING THE BACK WHEEL UNDER HEAVY LOAD AND OVER LARGE BUMPS IN THE ROAD. IT IS YOUR RESPONSIBILITY TO CHECK FOR THIS POSSIBILITY AND TAKE AVOIDING ACTION. FAILURE TO CHECK THIS COULD RESULT IN SERIOUS INJURY.**
- Refit both seats.
- Depending on local laws, attach enclosed red reflector (item 18) in an appropriate location.
- **Please test the indicators, rear light and licence plate illuminator before riding.**

Digital copies of these instructions are available to download from [www.rg-racing.com](http://www.rg-racing.com)

#### **GENERAL TORQUE SETTINGS**

M4 BOLT = 8Nm  
M5 BOLT = 12Nm  
M6 BOLT = 15Nm  
M8 BOLT = 20Nm  
M10 BOLT = 40Nm

ISSUE 1 18/06/2015 (NSY)

#### **CONSUMER NOTICE**

The catalogue description and any exhibition of samples are only broad indications of the Products and R&G may make design changes which do not diminish their performance or visual appeal and supplying them in such state shall conform to the order. The Buyer acknowledges no representation or warranty (other than as to title) has been given or will apply to the Products other than those in R&G's order or confirmation and the Buyer confirms it has chosen the Products as being of merchantable quality and suitable for its particular purposes. Where R&G fits the Products or undertakes other services it shall exercise reasonable skill and care and rectify any fault free of charge unless the workmanship has been disturbed. The Buyer is responsible for ensuring that the warranty on the motorcycle is not affected by the fitting of the Products. On return of any defective Products R&G shall at its option either supply a replacement or refund the purchase money but shall not be liable if the Products have been modified or used or maintained otherwise than in accordance with R&G's or manufacturer's instructions and good engineering practice or if the defect arises from accident or neglect. Other than identified above and subject to R&G not limiting its liability for causing death and personal injury, it shall not be liable for indirect or consequential loss and otherwise its liability shall be limited to the amounts paid by the Buyer for the Products or the fitting or service concerned. These terms do not affect the Buyer's statutory rights.

#### **R&G RACING RETURNS POLICY (NON-FAULTY GOODS)**

Returns must be pre-authorized (if not pre-authorized the return will be rejected). Goods may only be returned direct to us if they were purchased direct from us (customer must prove if necessary). Otherwise to be returned to original vendor. Goods must be in re-sellable condition, in the opinion of R&G Racing. All returns are subject to a 25% restocking and handling fee (25% of the gross value exc. P&P – at the prevailing price at time of purchase). The customer must pay any and all carriage charges. No returns of discontinued products, unless within 14 days of purchase. This policy does not affect your statutory rights and does not refer to faulty goods.

R&G Racing

Unit 1, Shelley's Lane, East Worldham, Alton, Hampshire, GU34 3AQ

Tel: +44 (0)1420 89007 Fax: +44 (0)1420 87301 [www.rg-racing.com](http://www.rg-racing.com) Email: [info@rg-racing.com](mailto:info@rg-racing.com)



LP0184

**INSTRUCTIONS DE MONTAGE POUR LP0184BK SUPPORT DE PLAQUE  
SUZUKI GSX-S 1000 2015-**

Page | 7



**Assurez vous que toutes les pièces soient présentes avant de procéder au montage.**

**La façon dont le kit est emballé ne correspond pas forcément à la façon de monter les pièces sur la moto.**

LES PIÈCES PRÉSENTÉES PEUVENT N'ÊTRE QUE REPRESENTATIVES, AFIN DE FACILITER ET CLARIFIER LES INSTRUCTIONS DE MONTAGE.

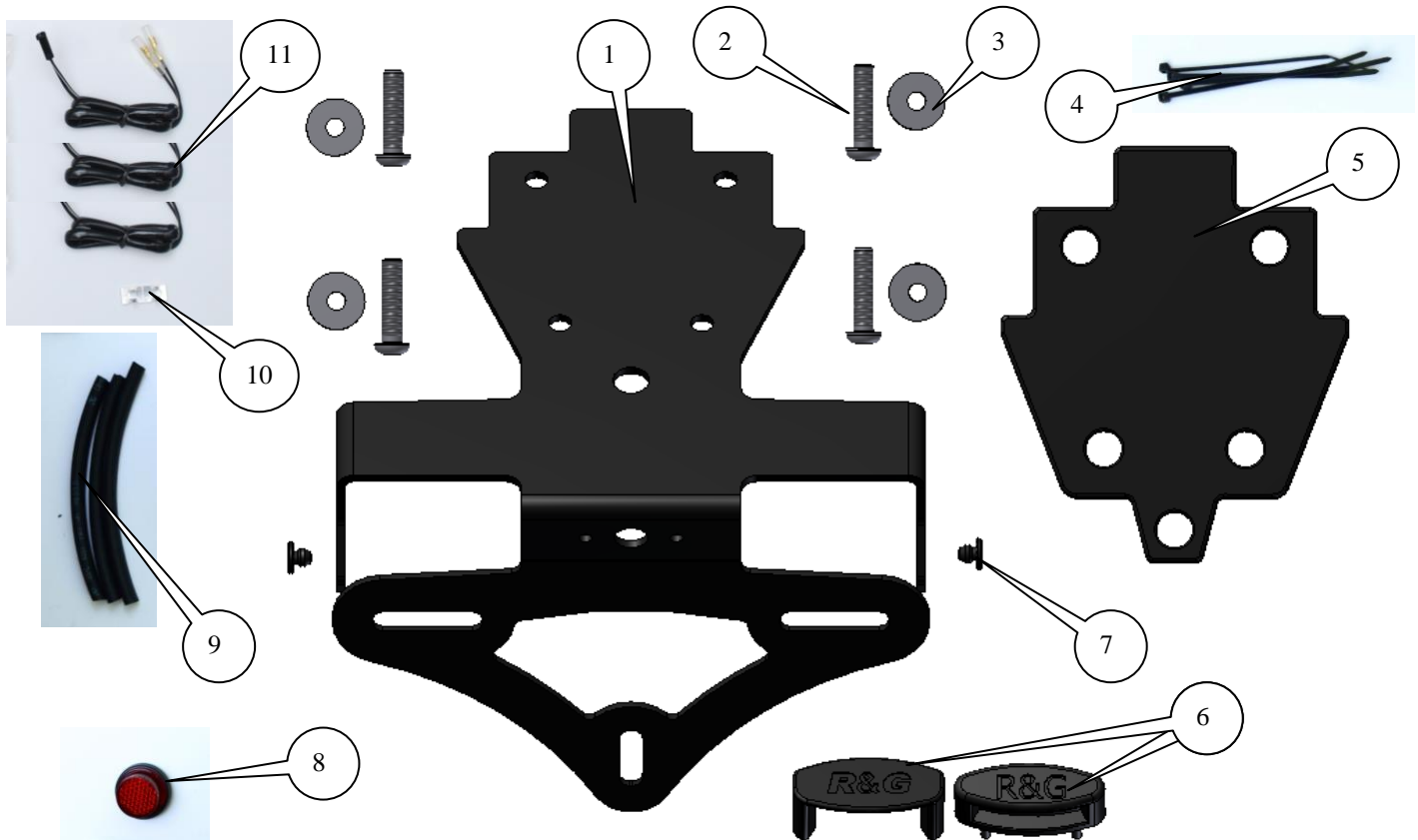



LP0184

Page | 8

### **LEGEND**

- ARTICLE 1 = SUPPORT DE PLAQUE (TB0184BK) (x1).  
ARTICLE 2 = M6x25mm BOULONS (x4).  
ARTICLE 3 = M6 RONDELLES (16mm O/DIA) (x4).  
ARTICLE 4 = COLLIERS DE SERRAGE (x4).  
ARTICLE 5 = ENTRETOISE (S0895) (x1).  
ARTICLE 6 = ASSEMBLAGE FEU DE PLAQUE (LA0002) (x1).  
ARTICLE 7 = RONDELLES DE CAOUTCHOUC (RB50-20-00FG) (x2).  
ARTICLE 8 = REFLECTEUR (REFL 1) (x1).  
ARTICLE 9 = 150mm LONGUEURS DE THERMO RETRACTABLES (x3).  
ARTICLE 10 = CLIPS AUTOCOLLANTS (x2).  
ARTICLE 11 = CONNECTEURS DE FEU DE PLAQUE ET CLIGNOTANT (CON0006) (x2).

Notez que si les kits sont emballés avec des rondelles en caoutchouc servant à tenir les composants, *ces rondelles doivent être jetées.*

### **OUTILS REQUIS**

- Jeu de clés Allen 4 et 5mm A/F.
  - Clé 10mm.
  - Pince 8mm.
- Tournevis cruciforme.
- Un peu de superglue.



PHOTO 1

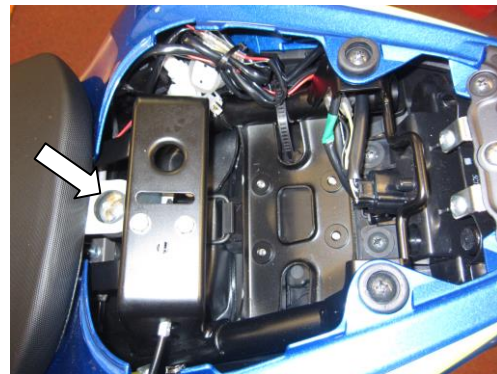

PHOTO 2





LP0184



PHOTO 3

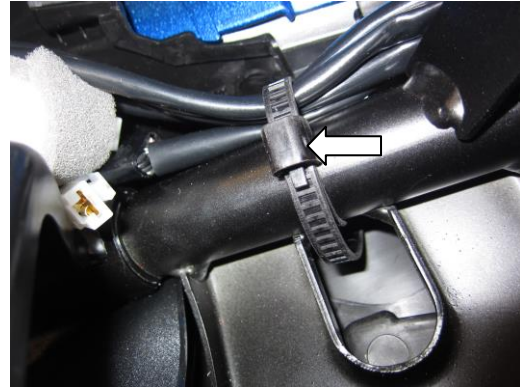

PHOTO 4

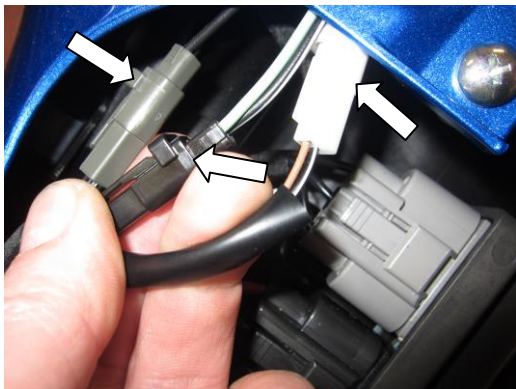

PHOTO 5



PHOTO 6



PHOTO 7

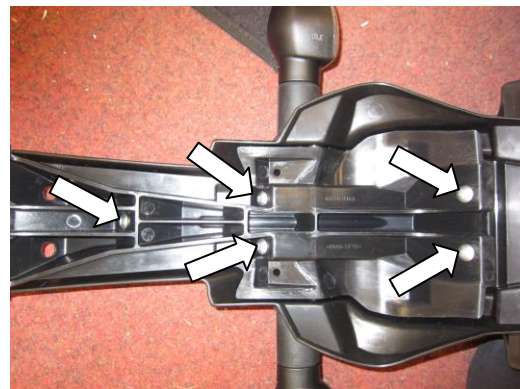

PHOTO 8



LP0184



PHOTO 9



PHOTO 10



PHOTO 11



PHOTO 12

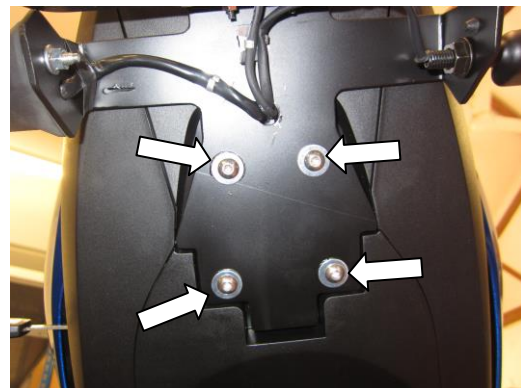
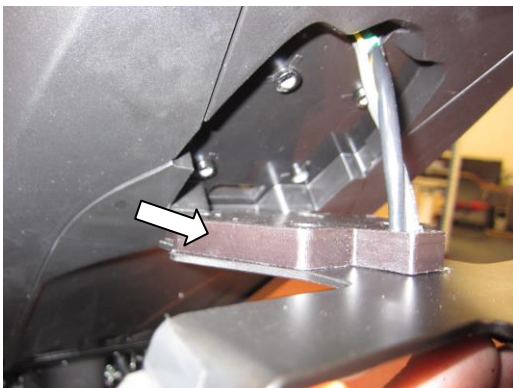



LP0184

PHOTO 13



PHOTO 15

PHOTO 14



PHOTO 16

Page | 11

### INSTRUCTIONS DE MONTAGE

- Enlever le siège passager à l'aide de la clé (photo 1).
- Enlever le boulon indiqué sur la photo 2 et enlever le siège pilote.
- Prend note du routage des fils, photo 3.
- Défaire les colliers de cablage, photo 4.
- Déconnecter le clignotant et les prises de fils de feu de plaque, photo 5.
- Enlever les 4 boulons, photo 6, puis enlever le support de plaque tout en faisant attention à éviter les accrocs avec le fil, photo 7.

#### Si vous utilisez les clignotants d'origine :

- Enlever les 5 vis, photo 8 et enlever le cache cable.
- Défaire et enlever l'écrou, photo 9 puis enlever le clignotant, voir photo 10.
- Répéter la manoeuvre pour l'autre clignotant.
- Monter les clignotants d'origine sur le nouveau support de plaque (article 1) en utilisant l'écrou d'origine, voir photo 11.

#### Si vous montez les mini clignotants R&G (R&G code produit RG370=Ampoule, RG371=LED ou RG372 = LED latérale

- Si vous montez les mini clignotants R&G, ils doivent être montés sur le trou arrière du support de plaque (article 1), 2 rondelles de caoutchouc sont fournies (article 7) pour boucher les trous restants. Utiliser les connecteurs fournis (article 11) Il est utile de connecter le métier à tisser pour vérifier que l'éclairage fonctionne (Si l'éclairage échoue, permutez les connecteurs). (Utiliser la gaine thermo rétractable pour protéger les fils (article 9).
- Monter le nouveau feu de plaque (article 6) sur l'assemblage support de plaque, voir photo 12 (Utiliser la thermo rétractable fournie (article 9) pour protéger les fils).
- **VOUS DEVREZ COLLER LE LINCEUL DE FEU AU FEU DE PLAQUE LED A L'AIDE DE LA SUPERGLUE.**
- Passer les fils dans le trou central du nouveau support de plaque.
- Placer l'entretoise (article 5) sur le support de plaque et passer les fils dans le trou central de l'entretoise, voir photo 13.

R&G Racing

Unit 1, Shelley's Lane, East Worldham, Alton, Hampshire, GU34 3AQ  
Tel: +44 (0)1420 89007 Fax: +44 (0)1420 87301 [www.rg-racing.com](http://www.rg-racing.com) Email: [info@rg-racing.com](mailto:info@rg-racing.com)



LP0184

Page | 12

- Monter l'ensemble en position tout en passant les fils dans le trou du passage de roue comme à l'origine, photo 13.
- Utiliser les 4 boulons M6 et rondelles (articles 2 et 3) dans les 4 trous dans le nouveau support de plaque et l'entretoise pas dessous et dans les trous filetés du sous-cadre comme à l'origine (voir photo 14) puis fixer.
- Si vous montez les clignotants d'origine, reconnectez les 3 prises de fils de clignotants comme à l'origine puis vérifier le bon fonctionnement.
- Si vous monter les mini clignotants R&G, utilisez les connecteurs fournis (article 11) pour reconnecter les clignotants puis vérifier le fonctionnement (Si l'éclairage échoue, permutez les connecteurs).
- Connecter le feu de plaque en utilisant le connecteur fourni (article 11) (Si l'éclairage échoue, permutez les connecteurs)..
- Utiliser les clips et colliers de serrage pour maintenir les fils organisés (articles 4 and 10).
- Monter la plaque d'immatriculation sur le support de plaque (peut nécessiter un perçage).
- **IMPORTANT: Si vous installez une grosse plaque, il y a un risque que la plaque entre en contact avec la roue arrière en cas de choc sur la route (bosse, grosse charge etc...). Il est de votre responsabilité de vérifier que cela ne puisse pas se produire. Ne pas effectuer ces vérifications peut entraîner des dommages ainsi que des blessures graves pour le pilote.**
- Remettre les sieges..
- Selon la loi locale, monter les réflecteurs (article 18) aux emplacements appropriés.
- Revérifiez que les clignotants et les feux de plaque fonctionnent bien avant de prendre la route.

**Ces instructions de montage sont disponibles sur [www.rg-racing.com](http://www.rg-racing.com)**

#### **COUPLES DE SERRAGE**

M4 BOULON = 8Nm  
M5 BOULON = 12Nm  
M6 BOULON = 15Nm  
M8 BOULON = 20Nm  
M10 BOULON = 40Nm

ISSUE 1 18/06/2015 (NSY)

#### **CONSUMER NOTICE**

The catalogue description and any exhibition of samples are only broad indications of the Products and R&G may make design changes which do not diminish their performance or visual appeal and supplying them in such state shall conform to the order. The Buyer acknowledges no representation or warranty (other than as to title) has been given or will apply to the Products other than those in R&G's order or confirmation and the Buyer confirms it has chosen the Products as being of merchantable quality and suitable for its particular purposes. Where R&G fits the Products or undertakes other services it shall exercise reasonable skill and care and rectify any fault free of charge unless the workmanship has been disturbed. The Buyer is responsible for ensuring that the warranty on the motorcycle is not affected by the fitting of the Products. On return of any defective Products R&G shall at its option either supply a replacement or refund the purchase money but shall not be liable if the Products have been modified or used or maintained otherwise than in accordance with R&G's or manufacturer's instructions and good engineering practice or if the defect arises from accident or neglect. Other than identified above and subject to R&G not limiting its liability for causing death and personal injury, it shall not be liable for indirect or consequential loss and otherwise its liability shall be limited to the amounts paid by the Buyer for the Products or the fitting or service concerned. These terms do not affect the Buyer's statutory rights.

R&G Racing

Unit 1, Shelley's Lane, East Worldham, Alton, Hampshire, GU34 3AQ

Tel: +44 (0)1420 89007 Fax: +44 (0)1420 87301 [www.rg-racing.com](http://www.rg-racing.com) Email: [info@rg-racing.com](mailto:info@rg-racing.com)



LP0184

**R&G RACING RETURNS POLICY (NON-FAULTY GOODS)**

Returns must be pre-authorized (if not pre-authorized the return will be rejected). Goods may only be returned direct to us if they were purchased direct from us (customer must prove if necessary). Otherwise to be returned to original vendor. Goods must be in re-sellable condition, in the opinion of R&G Racing. All returns are subject to a 25% restocking and handling fee (25% of the gross value exc. P&P – at the prevailing price at time of purchase). The customer must pay any and all carriage charges. No returns of discontinued products, unless within 14 days of purchase. This policy does not affect your statutory rights and does not refer to faulty goods.