

Information

PowerParts

45212948344

07. 2013

3.213.084



*KTM Sportmotorcycle AG
Stallhofnerstraße 3
A-5230 Mattighofen
www.ktm.com*

***KTM* POWERPARTS**

Danke, dass Sie sich für KTM PowerParts entschlossen haben.
Alle unsere Produkte wurden nach den höchsten Standards entwickelt und gefertigt, unter Verwendung der besten verfügbaren Materialien.
KTM PowerParts sind rennerprobt und gewährleisten ultimative Performance.

KTM KANN NICHT VERANTWORTLICH GEMACHT WERDEN FÜR FALSCHES MONTAGE ODER VERWENDUNG DIESES PRODUKTS. Bitte befolgen Sie die Montageanleitung. Fachmännische Beratung und korrekte Installation der KTM PowerParts durch einen autorisierten KTM Händler sind unerlässlich, um das Optimum an Sicherheit und Funktionalität zu gewährleisten.
Danke.

Thank you for choosing KTM PowerParts!
All of our products are designed and built to the highest standards using the finest materials available.
KTM PowerParts are race proven to offer the ultimate in performance.

KTM WILL NOT BE HELD LIABLE FOR IMPROPER INSTALLATION OR USE OF THIS PRODUCT. Please follow all instructions provided. Professional advice and proper installation of the KTM PowerParts by an authorized KTM dealer are essential to provide maximum safety and functions.
Thank you.

Grazie per aver deciso di acquistare un prodotto KTM PowerParts.
Tutti i nostri prodotti sono stati sviluppati e realizzati secondo i massimi standard e con l'impiego dei migliori materiali disponibili.
Le KTM PowerParts sono collaudate nelle competizioni ed assicurano altissime prestazioni.

KTM NON PUÒ ESSERE RESA RESPONSABILE PER UN MONTAGGIO O USO IMPROPRIO DI QUESTO PRODOTTO. Per favore osservate le istruzioni nel manuale d'uso. Al fine di garantire la massima sicurezza e il corretto funzionamento, è indispensabile farsi consigliare da persone esperte e competenti e far eseguire l'installazione delle KTM PowerPart presso i concessionari KTM autorizzati.
Grazie.

Nous vous remercions d'avoir choisi KTM PowerParts.
Tous nos produits ont été développés et réalisés selon les plus hauts standards et en utilisant les meilleurs matériaux disponibles.
Les PowerParts de KTM ont fait leurs preuves en compétition et garantissent les meilleures performances.

LA RESPONSABILITÉ DE KTM NE SAURAIT ÊTRE ENGAGÉE EN CAS D'ERREUR DANS LE MONTAGE OU L'UTILISATION DE CE PRODUIT. Il convient de respecter les instructions de montage.
Le conseil spécialisé et l'installation dans les règles de l'art des PowerParts KTM par un concessionnaire KTM agréé sont indispensables pour assurer un maximum de sécurité et de fonctionnalité.
Merci.

Gracias por haberse decidido por el PowerParts KTM.
Todos nuestros productos han sido desarrollados y producidos según los estándares más altos utilizando los mejores materiales disponibles.
Las KTM PowerParts están probadas en competencia y garantizan un óptimo rendimiento.

NO SE PUEDE HACER RESPONSABLE A LA KTM POR UN MONTAJE O UN USO INCORRECTO DE ESTE PRODUCTO. Le rogamos seguir las instrucciones para el montaje.
A fin de garantizar la máxima seguridad y un funcionamiento correcto es imprescindible acudir a un concesionario autorizado de KTM para obtener el mejor asesoramiento técnico e instalar correctamente las KTM PowerParts.
Gracias.

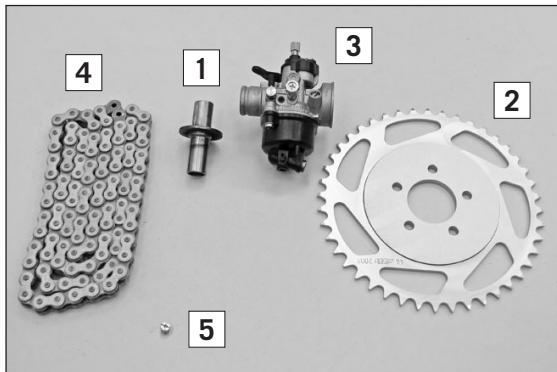

Lieferumfang:

1x Auspuflblende (1)
 1x Kettenrad 44Z (2)
 1x Vergaser Dellorto PHVA 12xS (3)
 1x Kette 1/2x3/16" L=104 Glieder (4)
 1x Hauptdüse 55 Dellorto (5)

45237024000
 45210151044
 45131001300
 45110265104
 45131023055

Vorarbeiten

- Fahrzeug gründlich reinigen.
- Sitzbank demontieren.
- Tank demontieren.

Montage

- Rutschdrehzahl der einstellbaren Kupplung auf das Minimum reduzieren (siehe Fahrzeug-Bedienungsanleitung).

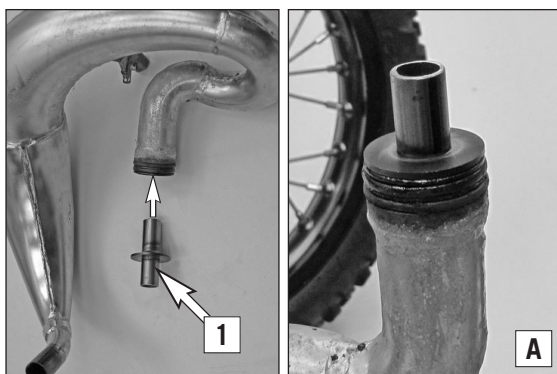

- Auspufffedern und Auspuff demontieren.
- Auspuflblende (1) in den Auspuff einsetzen (Position siehe Bild A).

HINWEIS:
 Auspuflblende mit der längeren Seite voran in den Auspuff montieren.

- Auspuff mit Auspuflblende montieren.

HINWEIS:
 Vor dem Festziehen der Schrauben, gesamte Anlage ausrichten.

- Auspufffedern montieren.

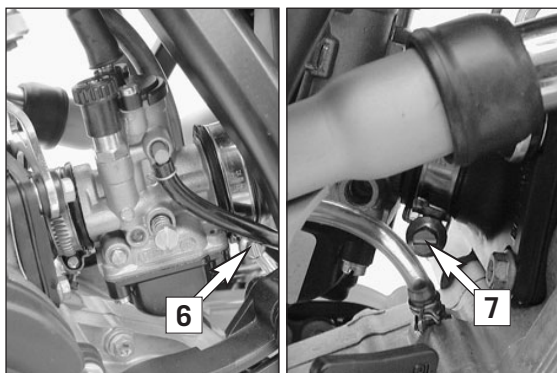

- Schelle (6) und (7) lösen.
- Vergaser aus dem Ansaugflansch ziehen.
- Vergaser nach vorne aus der Vergasermanschette ziehen.

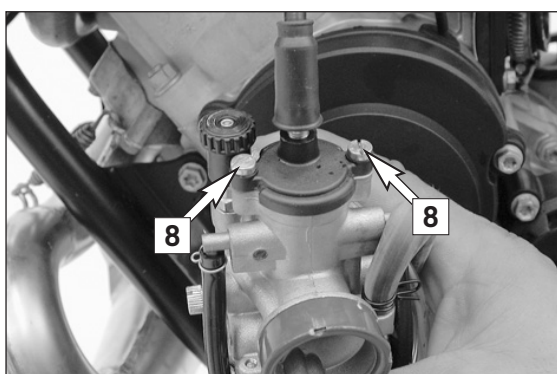

- Schrauben (8) entfernen.
- Gasschieberdeckel abnehmen und Gasschieber aus dem Vergaser ziehen.

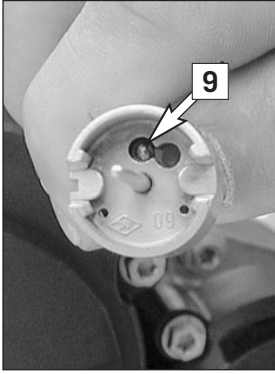

- Federtasse und Gasschieberfeder zurückziehen.
- Gasseil (9) aushängen.
- Gasschieber abnehmen.

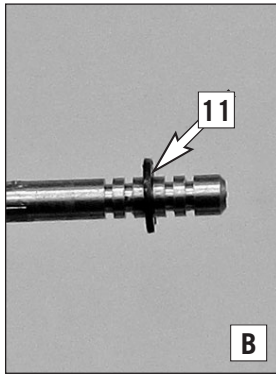
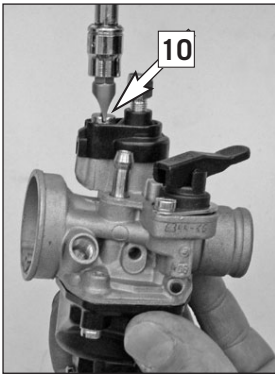

- Schraube (10) des neuen Vergasers (Lieferumfang) entfernen und Gasschieberdeckel abnehmen.
- Nadel entfernen und den Clip (11) auf die Position 3 setzen (siehe Bild B).

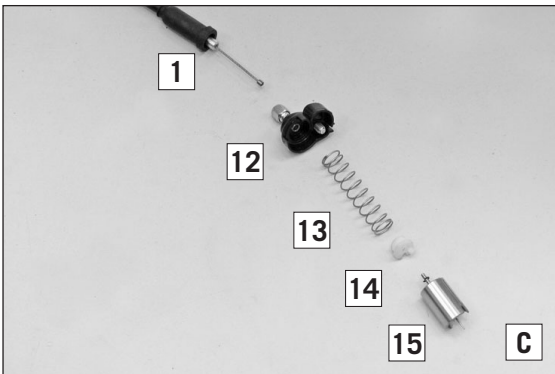

- Gasseil und Gasschieber wieder zusammenbauen.

HINWEIS:
Reihenfolge der Teile siehe Bild C.

- (9) Gasseil
- (12) Gasschieberdeckel (des neuen Vergasers)
- (13) Gasschieberfeder
- (14) Federtasse
- (15) Gasschieber mit Düsennadel

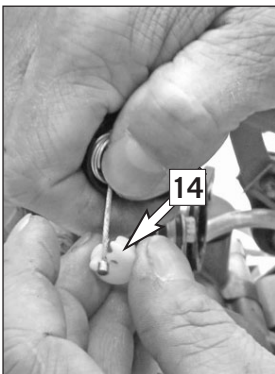

- Gasschieberdeckel (12) und Gasschieberfeder (13) auf das Gasseil (9) aufschieben.
- Gasschieberfeder zurückziehen und die Federtasse (14) montieren.



- Federtasse nach hinten ziehen (Bild D und E).

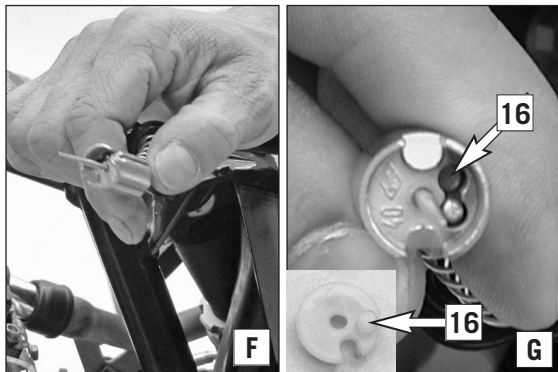

- Düsennadel im Gasschieber positionieren.
- Gasschieber mit Düsennadel montieren (Bild F und G).

⚠ ACHTUNG

Darauf achten, dass der Zapfen (16) der Federtasse in der Bohrung des Gasschiebers eingerastet ist! Ansonsten besteht die Gefahr, dass sich das Gasseil löst.

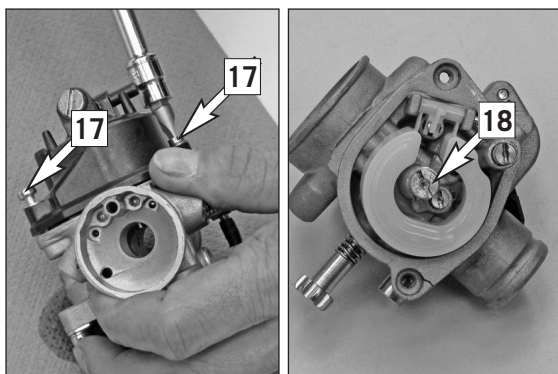

- Schrauben (17) des neuen Vergaseres (Lieferumfang) demontieren und Schwimmergehäuse entfernen.
- Hauptdüse (18) demontieren und Hauptdüse 55 (Lieferumfang) montieren (3Nm).
- Schwimmergehäuse positionieren und Schrauben (17) montieren (2Nm).

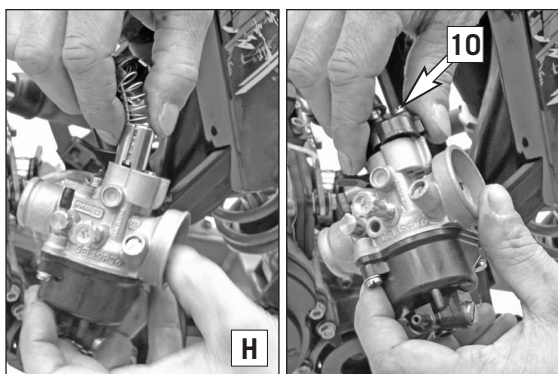

- Vormontierten Gasschieber in den neuen Vergaser (Lieferumfang) montieren (Bild H).
- Gasschieberdeckel positionieren und Schraube (10) montieren (3Nm).

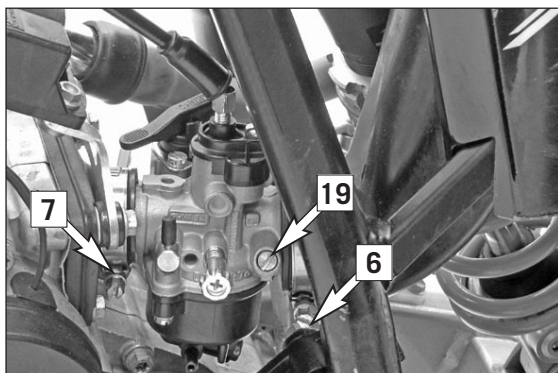

- Vergaser montieren und Schellen (6) und (7) festziehen.
- Luftregulierschraube (19) bis auf Anschlag im Uhrzeigersinn hineindrehen und 1 1/2 Umdrehungen gegen den Uhrzeigersinn herausdrehen.

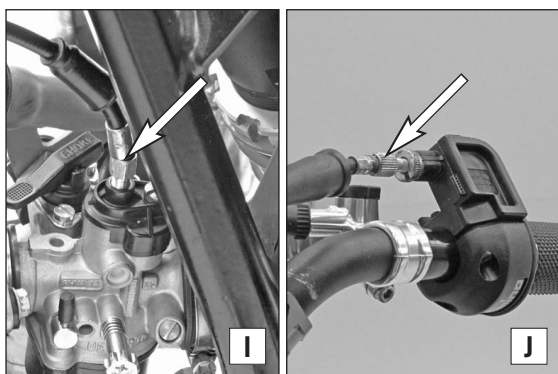

- Gasbowdenzugspiel kontrollieren und gegebenenfalls einstellen (Bild I und J).

Gasbowdenzugspiel	3...5mm
-------------------	---------

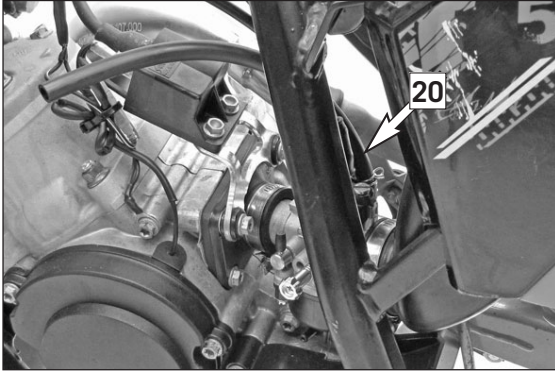

- Kraftstoffschlauch (**20**) vom Original Vergaser demontieren und am neuen Vergaser montieren.
- Original Kettenrad und Kette gegen die im Lieferumfang enthaltene Kette und Kettenrad ersetzen (Bild **K**).

HINWEIS:

Das Original Kettenritzel wird beibehalten.

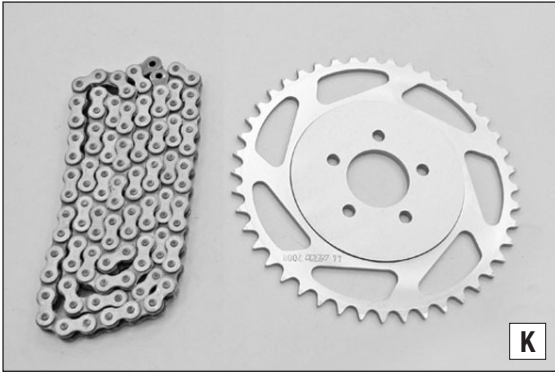
**Nacharbeiten**

- Tank montieren.
- Sitzbank montieren.

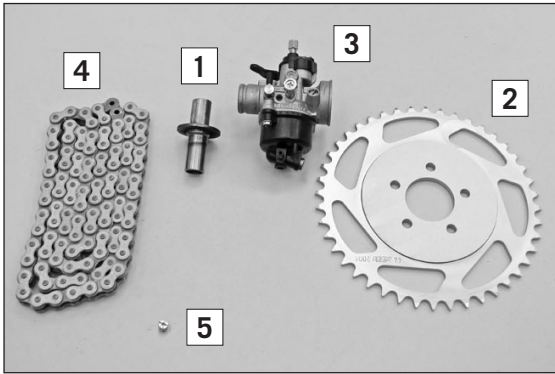

Scope of supply:

- 1x exhaust cover (1)
- 1x rear sprocket 44Z (2)
- 1x carburetor Dellorto PHVA 12xS (3)
- 1x chain 1/2x3/16" L=104 links (4)
- 1x main jet 55 Dellorto (5)

- 45237024000
- 45210151044
- 45131001300
- 45110265104
- 45131023055

Preparations

- Clean the vehicle thoroughly.
- Remove the seat.
- Remove the tank.

Assembly

- Reduce the slip speed of the adjustable clutch to a minimum value (see Vehicle Owner's Manual).

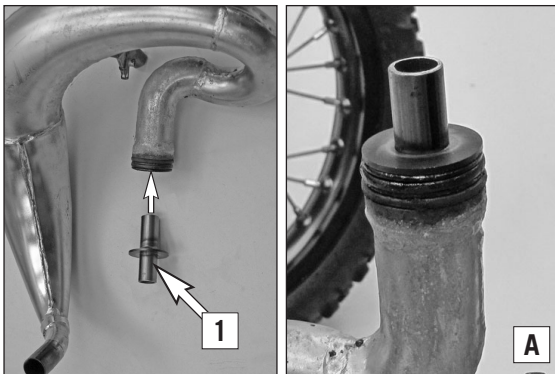

- Remove the exhaust springs and exhaust.
- Insert the exhaust cover (1) into the exhaust (see the position in Figure A).

NOTE:
Mount the exhaust cover in the exhaust with the longer side first.

- Mount the exhaust with the exhaust cover.

NOTE:
Before tightening the screws, align the entire unit.

- Mount the exhaust springs.

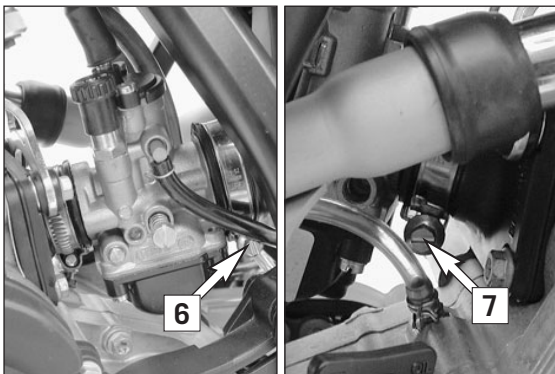

- Loosen clamps (6) and (7).
- Pull the carburetor out of the intake flange.
- Pull the carburetor forward out of the carburetor connection boot.

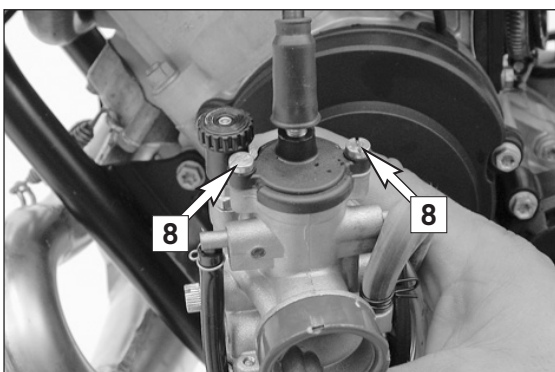

- Remove screws (8).
- Take off the throttle slide cover and pull the throttle slide out of the carburetor.

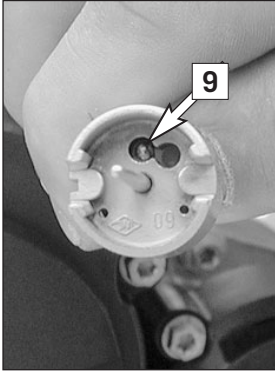

- Pull back the spring retainer and throttle slide spring.
- Detach the throttle cable wire (9).
- Take off the throttle slide.

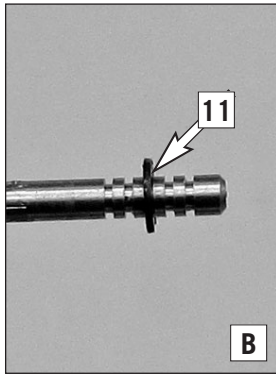
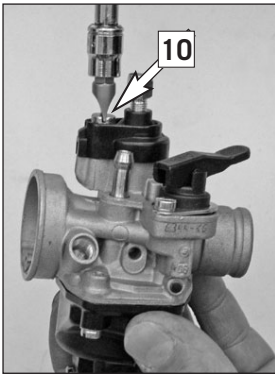

- Remove the screw (10) of the new carburetor (included) and take off the throttle slide cover.
- Remove the needle and mount the clip (11) at position 3 (see Figure B).

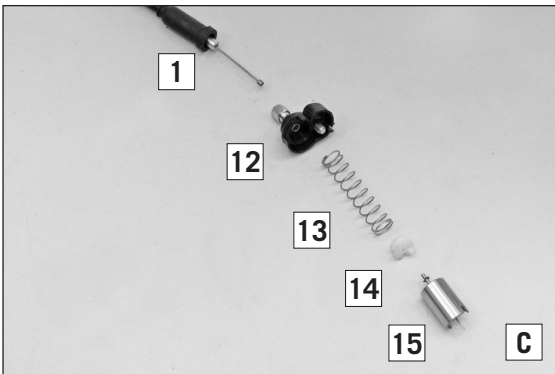

- Reassemble the throttle cable wire and throttle slide.

NOTE:
Sequence of parts, see Figure C.

- (9) Throttle cable wire
- (12) Throttle slide cover (of new carburetor)
- (13) Throttle slide spring
- (14) Spring retainer
- (15) Throttle slide with jet needle

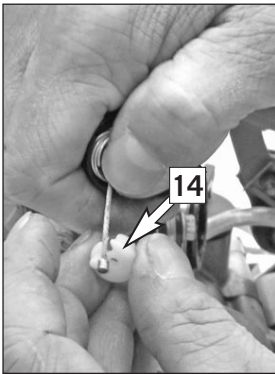

- Slide the throttle slide cover (12) and throttle slide spring (13) onto the throttle cable wire (9).
- Pull back the throttle slide spring and mount the spring retainer (14).



- Pull back the spring retainer (Figures D and E).

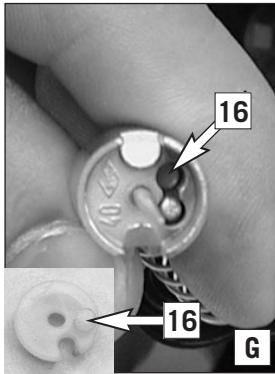

- Position the jet needle in the throttle slide.
- Mount the throttle slide with the jet needle (Figures **F** and **G**).

WARNING

Ensure that the pin (16) of the spring retainer is engaged in the hole of the throttle slide. Otherwise, there is a danger of the throttle cable wire coming loose.

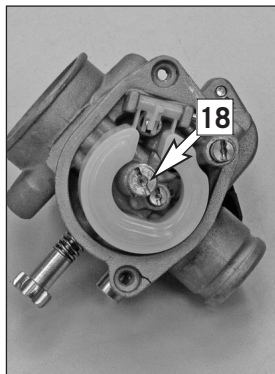
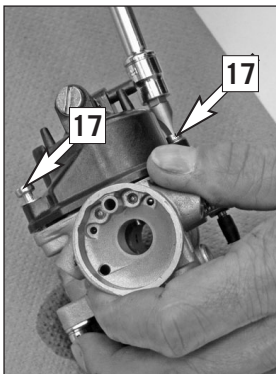

- Remove the screws (17) of the new carburetor (included) and take off the float chamber.
- Remove the main jet (18) and mount main jet 55 (included) with 3 Nm.
- Position the float chamber and mount the screws (17) with 2 Nm.

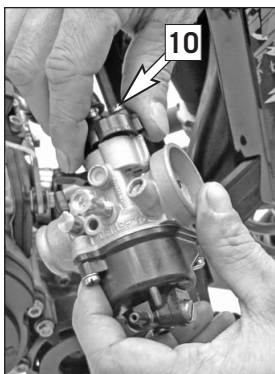

- Mount the pre-mounted throttle slide into the new carburetor (included, Figure **H**).
- Position the throttle slide cover and mount the screw (10) with 3 Nm.

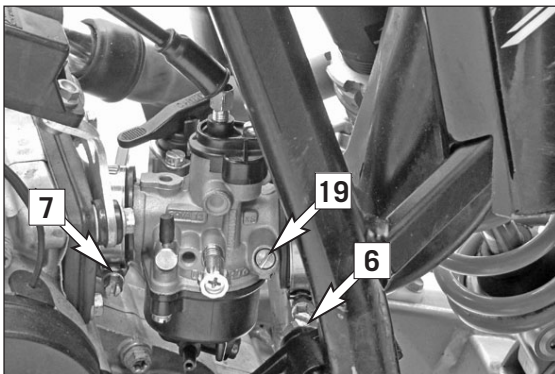

- Mount the carburetor and tighten clamps (6) and (7).
- Turn the air control screw (19) all the way clockwise and turn back out 1 1/2 rotations counterclockwise.

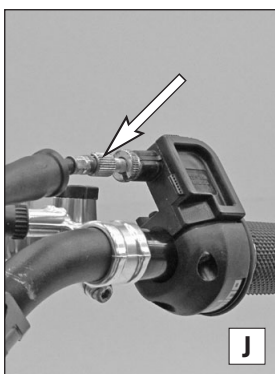

-Check the play in the throttle cable and adjust if necessary (Figures **I** and **J**).

Play in throttle cable	3...5 mm
------------------------	----------

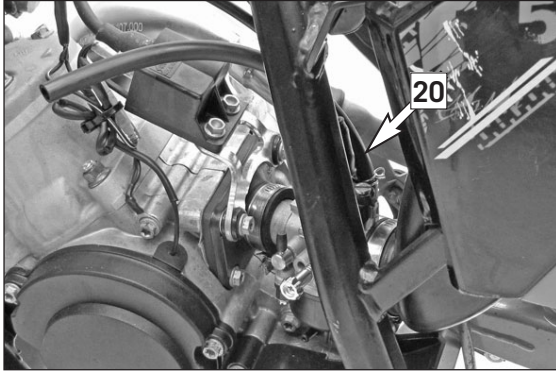

- Remove the fuel hose **(20)** from the original carburetor and mount on the new carburetor.
- Replace the original rear sprocket and chain with the rear sprocket and chain contained in the delivery (Figure **K**).

NOTE:

The original engine sprocket stays in place.

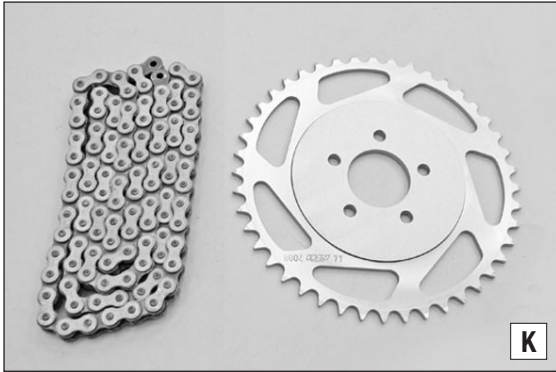

Final steps

- Mount the tank.
- Mount the seat.

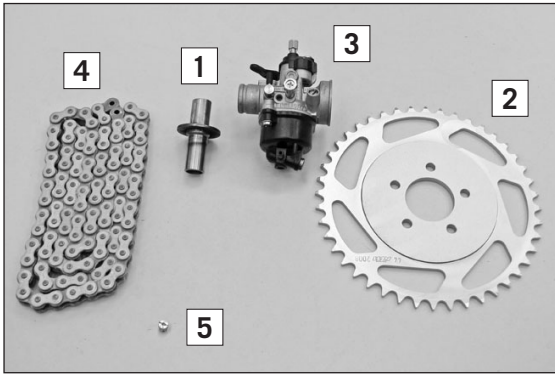

Volume della fornitura:

- N. 1 terminale di scarico (1)
- N. 1 corona dentata 44Z (2)
- N. 1 carburatore Dellorto PHVA 12xS (3)
- N. 1 catena 1/2x3/16" L=104 maglie (4)
- N. 1 getto massimo 55 Dellorto (5)

45237024000
 45210151044
 45131001300
 45110265104
 45131023055

Operazioni preliminari

- Pulire a fondo il veicolo.
- Smontare la sella.
- Smontare il serbatoio.

Montaggio

- Ridurre al minimo la velocità di slittamento della frizione regolabile (vedi il manuale d'uso del veicolo).

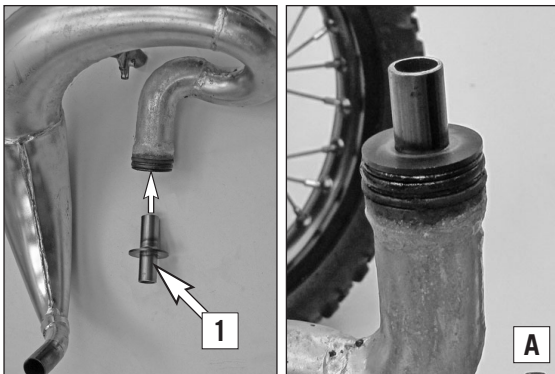

- Smontare le molle dell'impianto di scarico e lo scarico.
- Inserire il terminale di scarico (1) nello scarico (v. posizione figura A).

NOTA:

Montare nello scarico il terminale, con il lato più lungo rivolto in avanti.

- Montare lo scarico con il terminale di scarico.

NOTA:

Prima di serrare le viti, allineare l'impianto completo.

- Montare le molle dell'impianto di scarico.

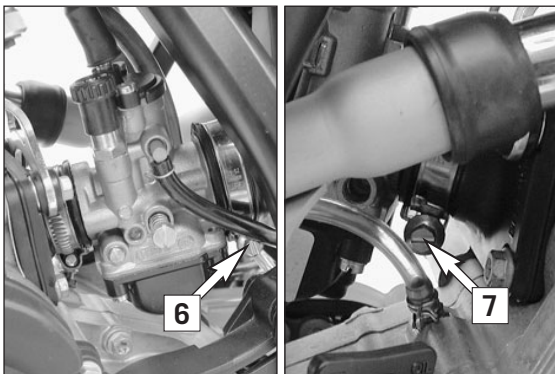

- Allentare le fascette (6) e (7).
- Estrarre il carburatore dalla flangia di aspirazione.
- Tirare il carburatore in avanti, fuori dal manicotto.

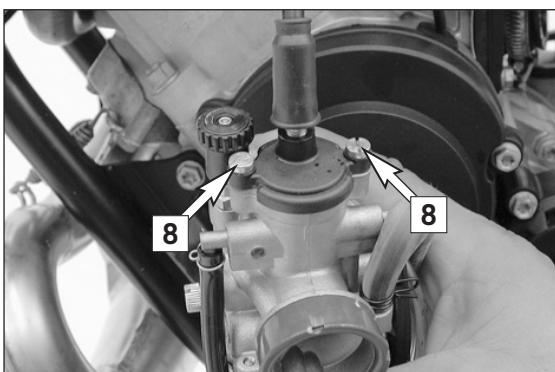

- Rimuovere le viti (8).
- Rimuovere il coperchio della valvola del gas ed estrarre la valvola del gas dal carburatore.

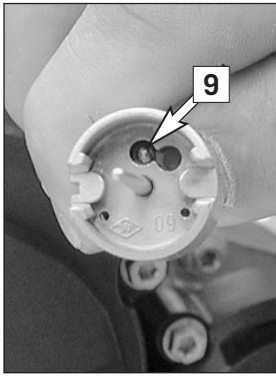

- Tirare indietro il bicchierino molla e la molla della valvola del gas.
- Disimpegnare il cavo del gas (9).
- Rimuovere la valvola del gas.

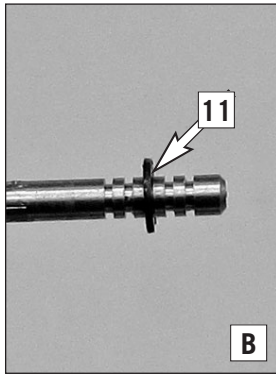
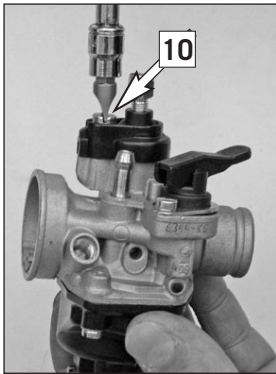

- Rimuovere la vite (10) del nuovo carburatore (in dotazione) e rimuovere il coperchio della valvola del gas.
- Rimuovere lo spillo e posizionare il fermaglio (11) in posizione 3 (vedi figura B).

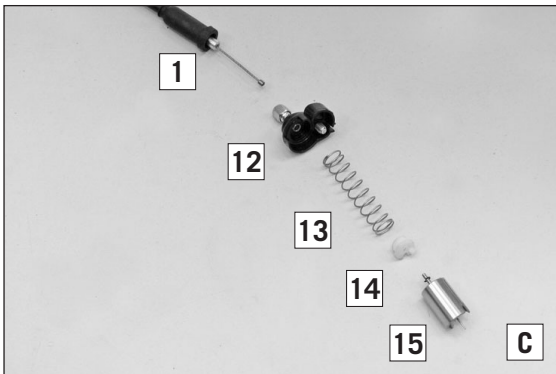

- Riasssemblare il cavo e la valvola del gas.

NOTA:

Per conoscere l'ordine dei componenti, fare riferimento alla figura C.

- (9) Cavo del gas
- (12) Coperchio della valvola del gas (del nuovo carburatore)
- (13) Molla della valvola del gas
- (14) Bicchierino molla
- (15) Valvola del gas con spillo conico

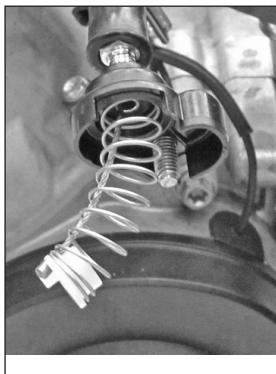
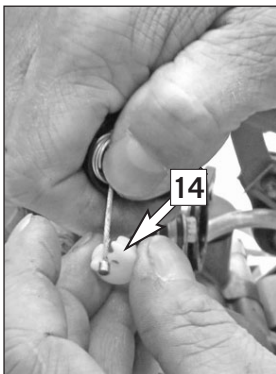

- Spingere il coperchio della valvola del gas (12) e la molla della valvola del gas (13) sul cavo del gas (9).
- Tirare indietro la molla della valvola del gas e montare il bicchierino molla (14).



- Tirare indietro il bicchierino molla (figure D ed E).

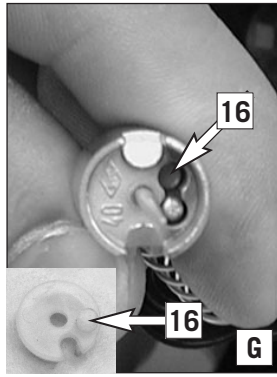

- Posizionare lo spillo conico sulla valvola del gas.
- Montare la valvola del gas con lo spillo conico (figure **F** e **G**).

⚠ ATTENZIONE

Assicurarsi che il perno (16) del bicchierino molla si innesti nel foro della valvola del gas! Altrimenti vi è il rischio che il cavo del gas si allenti.

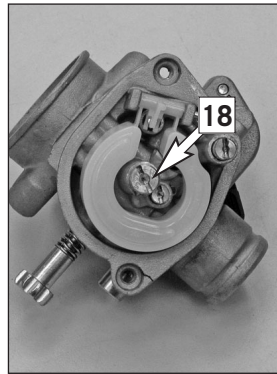
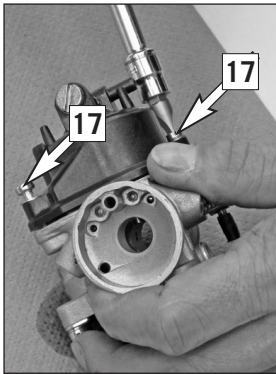

- Estrarre le viti (17) del nuovo carburatore (in dotazione) e rimuovere la vaschetta del carburatore.
- Smontare il getto massimo (18) e montare il getto massimo 55 (in dotazione) (3 Nm).
- Posizionare la vaschetta del carburatore e montare le viti (17) (2 Nm).

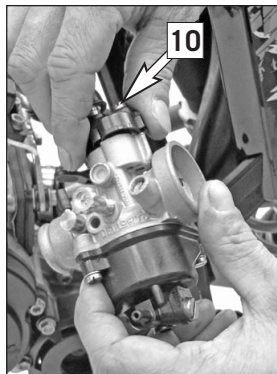

- Montare nel nuovo carburatore (in dotazione) la valvola del gas premon-tata (figura **H**).
- Posizionare il coperchio della valvola del gas e montare la vite (10) (3 Nm).

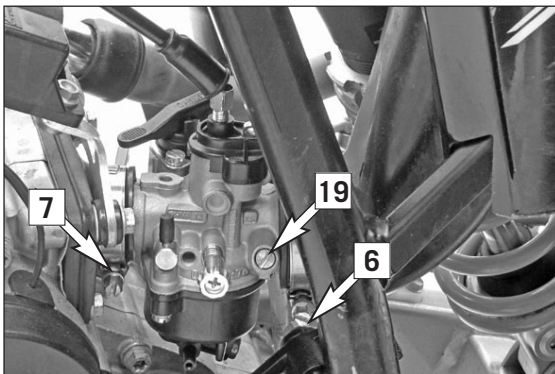

- Montare il carburatore e serrare le fascette (6) e (7).
- Avvitare la vite di registro dell'aria (19) fino a battuta in senso orario, quindi svitarla di 1 1/2 giro in senso antiorario.

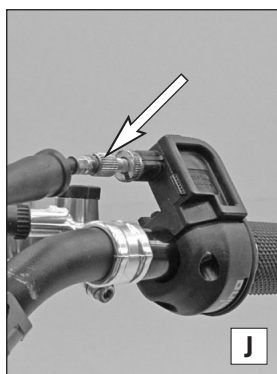

- Controllare il gioco del cavo flessibile del gas ed eventualmente regolarlo (figure **I** e **J**).

Gioco del cavo flessibile del gas	3...5 mm
-----------------------------------	----------

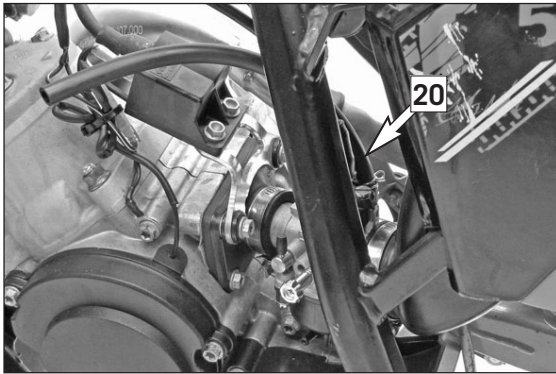

- Smontare dal carburatore originale il tubo del carburante **(20)** e montarlo sul nuovo carburatore.
- Sostituire la corona dentata e la catena originali con quelle fornite in dotazione (figura **K**).

NOTA:

Il pignone originale va invece mantenuto.

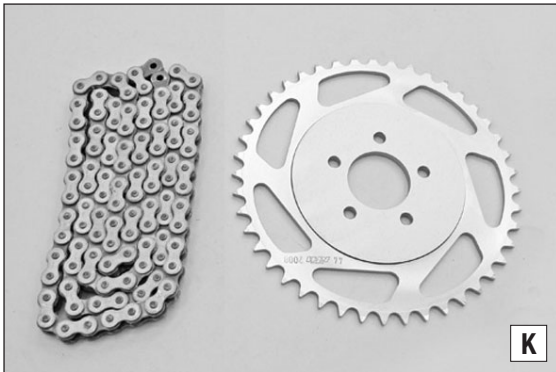

Operazioni successive

- Montare il serbatoio.
- Montare la sella.

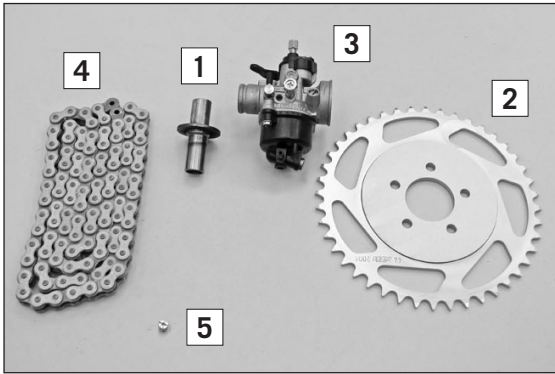

Étendue de la livraison :

- 1x Déflecteur d'échappement (1)
- 1x Couronne 44Z (2)
- 1x Carburateur Dellorto PHVA 12xS (3)
- 1x Chaîne 1/2x3/16" L=104 maillons (4)
- 1x Buse principale 55 Dellorto (5)

- 45237024000
- 45210151044
- 45131001300
- 45110265104
- 45131023055

Travaux préalables

- Nettoyer le véhicule à fond.
- Démonter la selle.
- Démonter le réservoir.

Montage

- La vitesse de glissement de l'accouplement réglable doit être réduite au minimum (voir le manuel d'utilisation du véhicule).

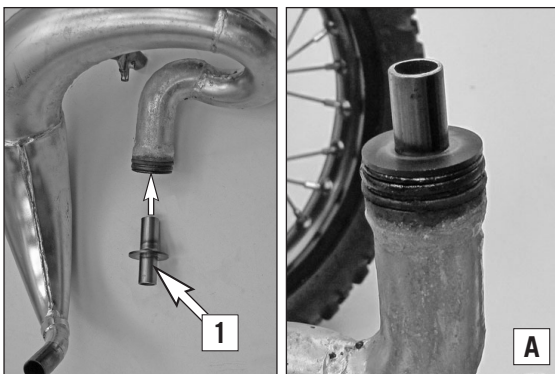

- Démonter les ressorts d'échappement et l'échappement.
- Mettre le déflecteur d'échappement (1) dans l'échappement (position voir figure A).

REMARQUE :

Monter le déflecteur d'échappement dans l'échappement, avec le côté le plus long en premier.

- Monter l'échappement muni de son déflecteur.

REMARQUE :

Avant de serrer les vis, orienter l'ensemble correctement.

- Monter les ressorts d'échappement.

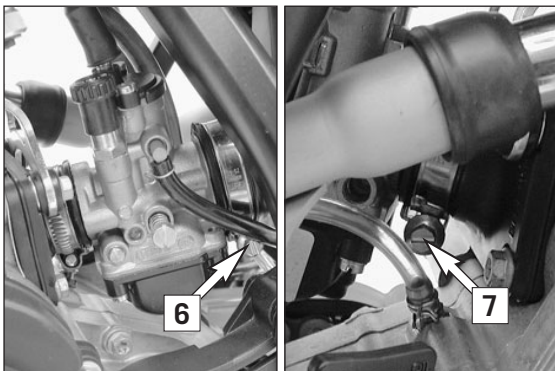

- Desserrer les colliers (6) et (7).
- Extraire le carburateur de la pipe d'admission.
- Extraire le carburateur du manchon du carburateur, en le sortant par l'avant.

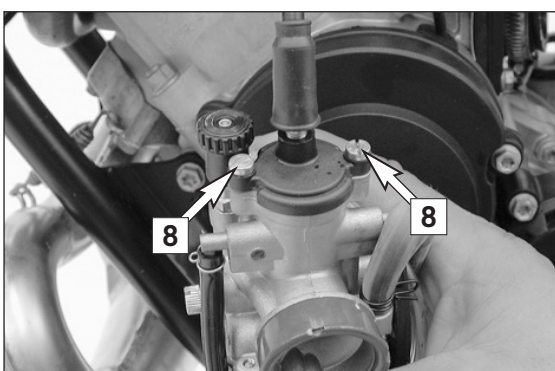

- Retirer les vis (8).
- Déposer le couvercle du boisseau et sortir le boisseau du carburateur.

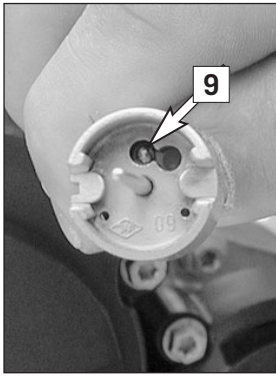

- Repousser la coupelle de ressort et le ressort du boisseau.
- Décrocher le câble d'accélérateur (9).
- Déposer le boisseau.

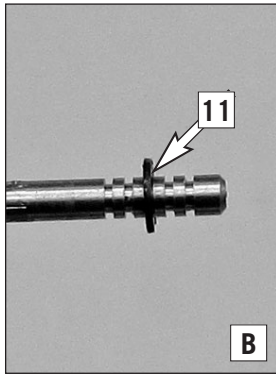
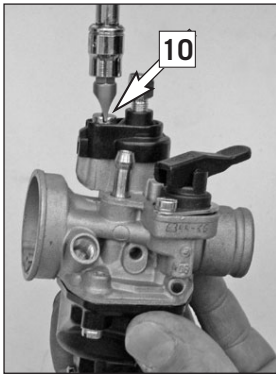

- Enlever la vis (10) du nouveau carburateur (contenu de la livraison) et déposer le couvercle du boisseau.
- Enlever l'aiguille et placer le clip (11) en position 3 (voir figure B).

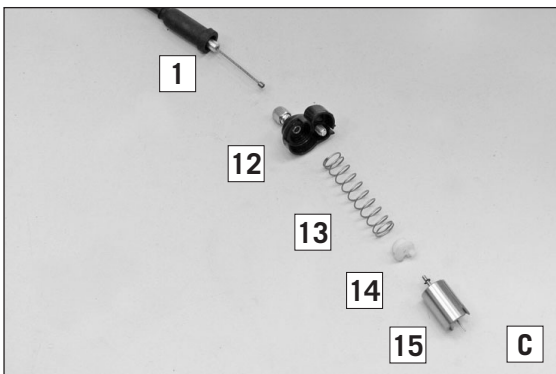

- Assembler le câble d'accélérateur et le boisseau.

REMARQUE :

Ordre de montage des pièces, voir figure C.

- (9) Câble d'accélérateur
- (12) Couvercle du boisseau (du nouveau carburateur)
- (13) Ressort de boisseau
- (14) Coupelle de ressort
- (15) Boisseau avec aiguilles

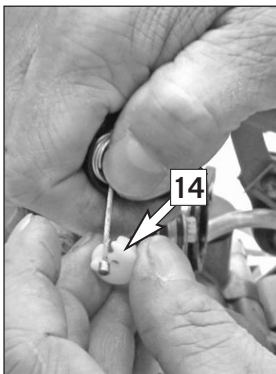

- Emmancher le couvercle de boisseau (12) et le ressort de boisseau (13) sur le câble d'accélérateur (9).
- Repousser le ressort de boisseau pour monter la coupelle (14).



- Tirer la coupelle vers l'arrière (figures D et E).

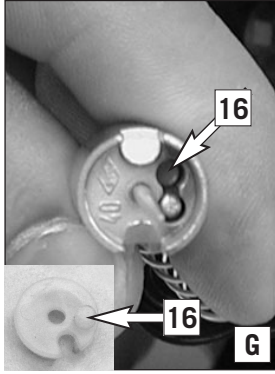

- Placer l'aiguille dans le boisseau.
- Monter le boisseau avec l'aiguille (figures F et G).

⚠ ATTENTION

Veiller à ce que le maneton (16) de la coupelle s'emboîte parfaitement dans l'alésage du boisseau ! Dans le cas contraire, le câble d'accélérateur risque de desserrer.

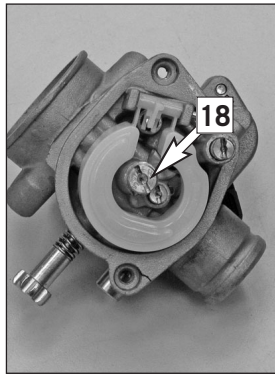
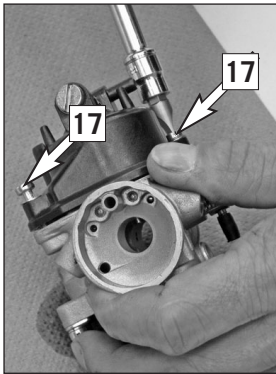

- Enlever les vis (17) du nouveau carburateur (contenu de la livraison) et déposer la cuve.
- Démonter la buse principale (18) et monter la buse principale 55 (contenu de la livraison) (3Nm).
- Mettre en place la cuve à niveau constant et visser les vis (17) (2Nm).

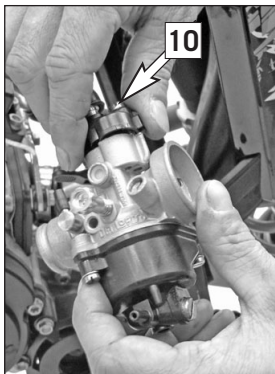

- Monter le boisseau préassemblé dans le nouveau carburateur (contenu de la livraison) (figure H).
- Mettre en place le couvercle de boisseau et visser la vis (10) (3Nm).

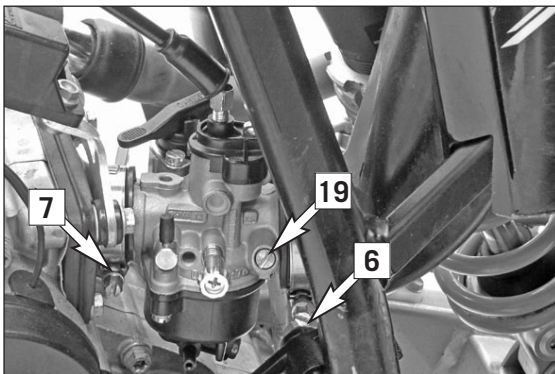

- Monter le carburateur et serrer les colliers (6) et (7).
- Visser la vis de régulation d'air (19) jusqu'en butée, dans le sens horaire, puis la dévisser d'1 1/2 tour dans le sens contraire.

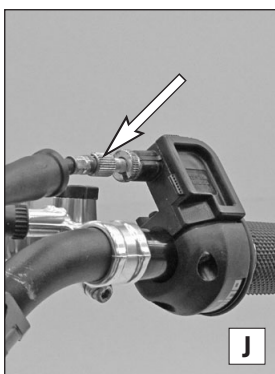

- Contrôler le jeu du câble d'accélérateur et le régler si nécessaire (figures I et J).

Jeu du câble d'accélérateur	3...5mm
-----------------------------	---------

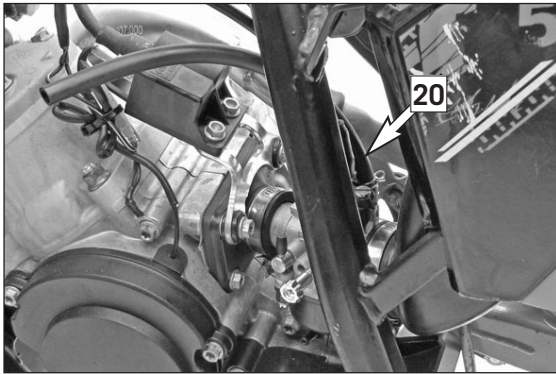

Déconnecter la durite de carburant (**20**) sur le carburateur d'origine et la raccorder au nouveau carburateur.

- Remplacer la couronne d'origine et la chaîne par la chaîne et la couronne fournies dans le contenu de la livraison (figure **K**).

REMARQUE :
Conserver le pignon d'origine.

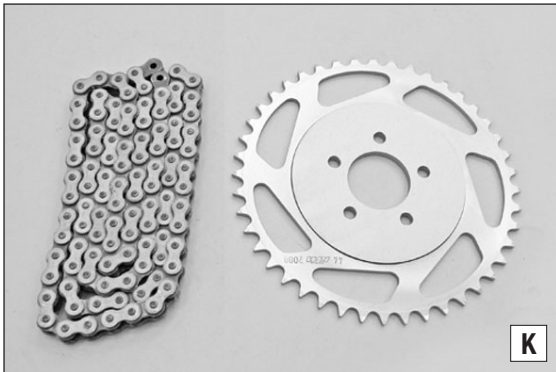

Travaux ultérieurs

- Monter le réservoir.
- Monter la selle.

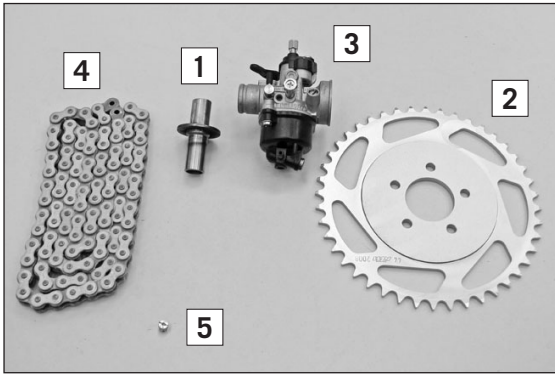

Volumen de suministro:

- 1 panel de escape (1)
- 1 corona de cadena 44Z (2)
- 1 carburador Dellorto PHVA 12xS (3)
- 1 cadena 1/2x3/16" L=104 eslabones (4)
- 1 chiclé principal 55 Dellorto (5)

- 45237024000
- 45210151044
- 45131001300
- 45110265104
- 45131023055

Trabajos previos

- Limpiar el vehículo a fondo.
- Desmontar el asiento.
- Desmontar el depósito.

Montaje

- Reducir al mínimo el régimen de revoluciones de deslizamiento del embrague ajustable (véase el manual de instrucciones del vehículo).

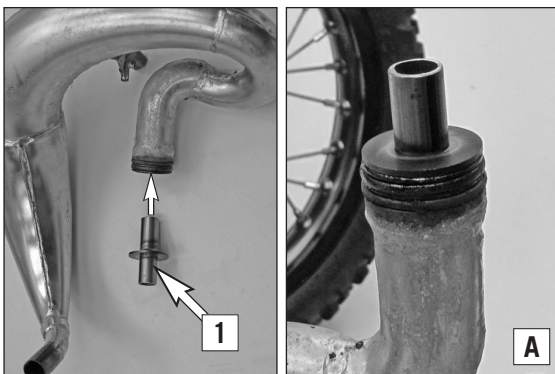

- Desmontar los muelles del tubo de escape y el silenciador.
- Colocar el panel de escape (1) en el equipo de escape (véase la posición en la figura A).

NOTA:

Montar el panel de escape en el equipo de escape con el lado largo delante.

- Montar el equipo de escape con el panel de escape.

NOTA:

Antes de apretar los tornillos, alinear todo el sistema.

- Montar los muelles del tubo de escape.

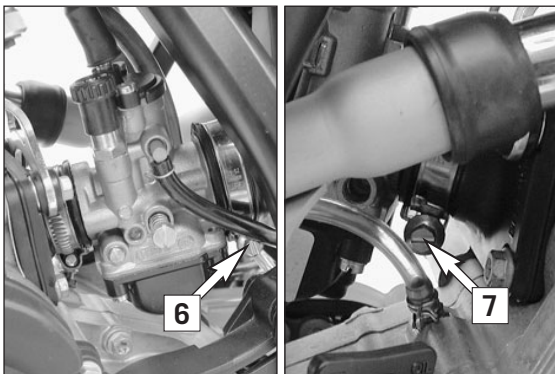

- Aflojar las abrazaderas (6) y (7).
- Retirar el carburador de la brida de succión.
- Retirar el carburador del manguito del carburador hacia delante.

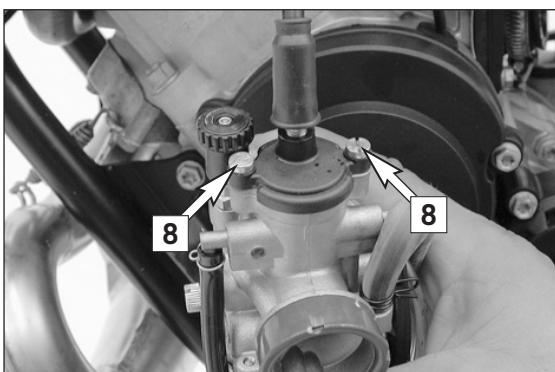

- Retirar los tornillos (8).
- Quitar la tapa de la corredera del gas y retirar la corredera del gas del carburador.

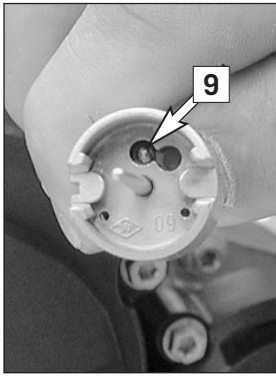

- Retraer la copa del muelle y el muelle de la corredera del gas.
- Desenganchar el cable del gas (9).
- Quitar la corredera del gas.

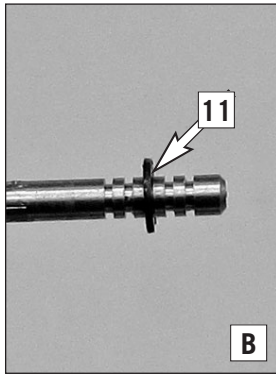
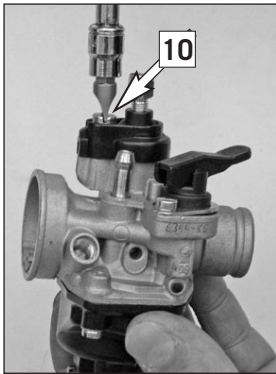

- Retirar el tornillo (10) del nuevo carburador (volumen de suministro) y quitar la tapa de la corredera del gas.
- Retirar la aguja y colocar el clip (11) en la posición 3 (véase la figura B).

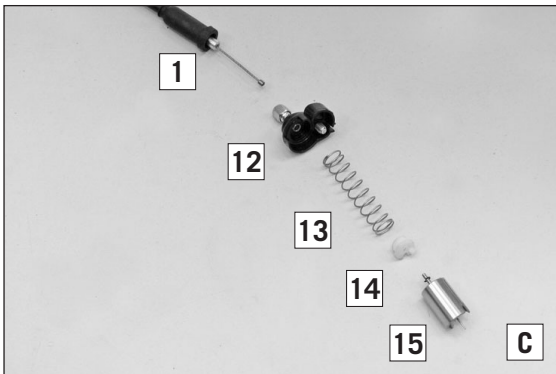

- Volver a ensamblar el cable del gas y la corredera del gas.

NOTA:

Véase el orden de las piezas en la figura C.

- (9) Cable del gas
- (12) Tapa de la corredera del gas (del nuevo carburador)
- (13) Muelle de la corredera del gas
- (14) Copa del muelle
- (15) Corredera del gas con aguja del carburador

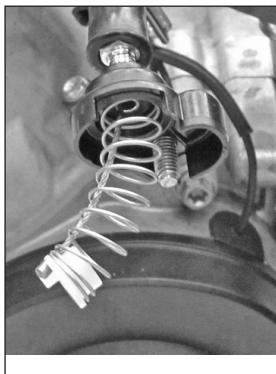
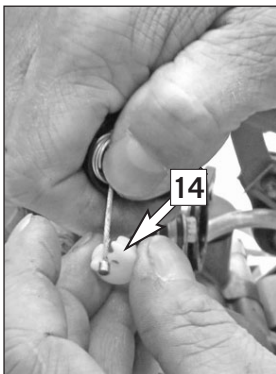

- Colocar la tapa de la corredera del gas (12) y el muelle de la corredera del gas (13) en el cable del gas (9).
- Retraer el muelle de la corredera del gas y montarlo en la copa del muelle (14).



- Tirar hacia atrás de la copa del muelle (figuras D y E).

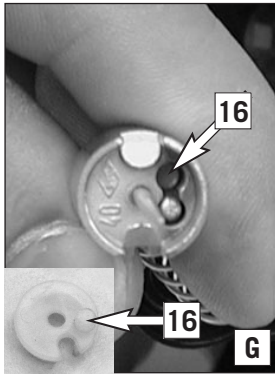

- Posicionar la aguja del carburador en la corredera del gas.
- Montar la corredera del gas con la aguja del carburador (figuras F y G).

⚠ ATENCION

¡Prestar atención a que la espiga (16) de la copa del muelle esté enclavada en el orificio de la corredera del gas! En caso contrario, existe peligro de que se suelte el cable del gas.

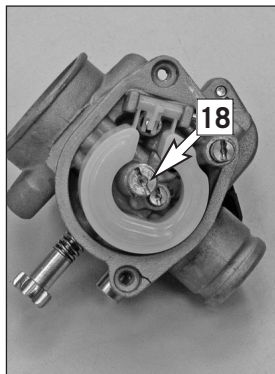
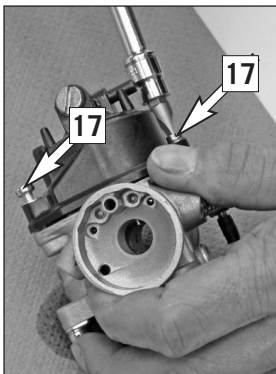

- Desmontar los tornillos (17) del nuevo carburador (volumen de suministro) y retirar la carcasa del flotador.
- Desmontar el chicle principal (18) y montar el chicle principal 55 (volumen de suministro) (3 Nm).
- Posicionar la carcasa del flotador y montar los tornillos (17) (2 Nm).

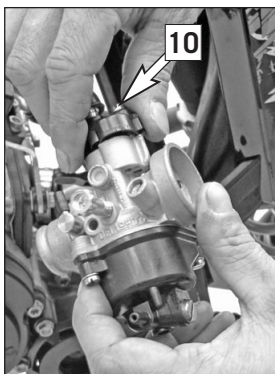

- Montar la corredera del gas premontada en el nuevo carburador (volumen de suministro) (figura H).
- Posicionar la tapa de la corredera del gas y montar el tornillo (10) (3 Nm).

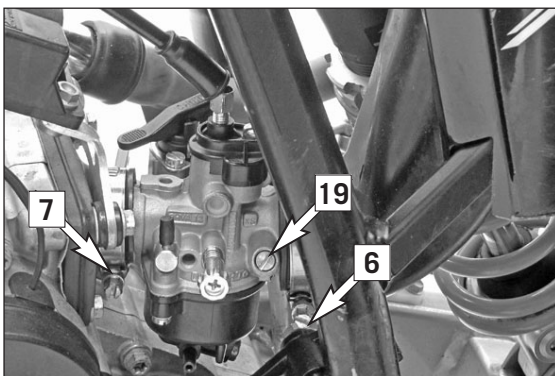

- Montar el carburador y apretar las abrazaderas (6) y (7).
- Enroscar el tornillo de regulación del aire (19) hasta el tope en sentido horario y desenroscarlo 1 1/2 vuelta en sentido antihorario.

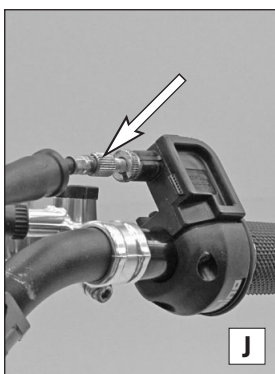

- Controlar la holgura del cable bowden del acelerador y ajustarla según sea necesario (figuras I y J).

Holgura del cable bowden del acelerador	3...5 mm
---	----------

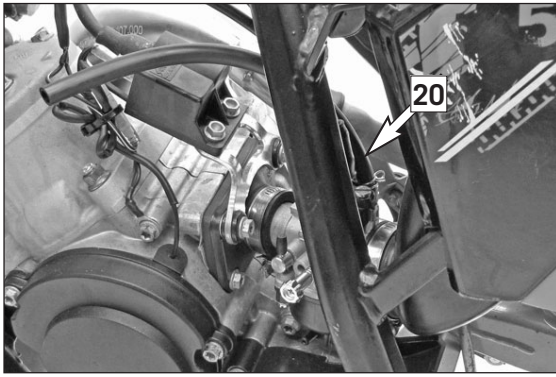

- Desmontar la manguera de combustible (**20**) del carburador original y montarla en el nuevo carburador.
- Sustituir la corona de cadena y la cadena originales por la corona de cadena y la cadena incluidas en el volumen de suministro (figura **K**).

NOTA:

Debe conservarse el piñón de cadena original.

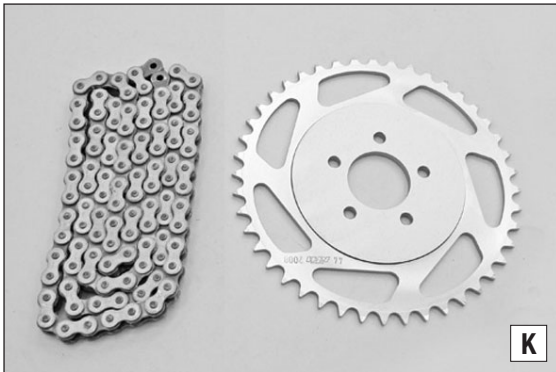

Trabajos posteriores

- Montar el depósito.
- Montar el asiento.