

***KTM* POWERPARTS**
INFORMATION

USB POWER OUTLET KIT



64112950044

11.2018
3.213.830



KTM Sportmotorcycle GmbH
5230 Mattighofen, Austria
www.ktm.com



3 DEUTSCH

Wir freuen uns, dass Sie sich für dieses Produkt entschieden haben.

Unser hochwertiges Qualitätsprodukt ist rennerprobt und wurde speziell für sportliche Herausforderungen entwickelt. Eine korrekte Montage des Produktes ist unerlässlich, um ein Maximum an Sicherheit und Funktionalität gewährleisten zu können. Bitte befolgen Sie daher die Montageanleitung oder wenden Sie sich an Ihren autorisierten Fachhändler.

Für falsche Montage oder Verwendung dieses Produktes kann der (Quasi-)Hersteller bzw. Lieferant nicht zur Verantwortung gezogen werden.
Vielen Dank.

6 ENGLISH

Thank you for choosing this product.

Our high quality product has been tested under racing conditions and was developed specifically for use in sports activities. Correct installation of the product is essential to ensure that a maximum degree of safety and functionality is achieved. Therefore, please follow the installation instructions or contact your authorized dealer.

The (quasi) manufacturer or supplier cannot be held responsible for products that are incorrectly mounted or inappropriately used.
Thank you.

9 ITALIANO

Grazie per aver scelto questo prodotto.

Questo nostro prodotto di pregiata qualità è collaudato nelle competizioni ed è stato sviluppato specificamente per gare sportive. Il montaggio corretto del prodotto è fondamentale per garantirne la massima sicurezza e funzionalità. Rispetti quindi le istruzioni di montaggio o rivolgerti al proprio concessionario autorizzato.

Il produttore (detentore del marchio)/fornitore non può essere considerato responsabile per un montaggio o impiego errato del presente prodotto.
Vi ringraziamo per l'attenzione!

12 FRANÇAIS

Merci d'avoir porté votre choix sur ce produit.

Notre produit de haute qualité est éprouvé pour les compétitions et a été conçu spécialement pour un usage sportif. Un montage approprié du produit est indispensable pour garantir une sécurité et une fonctionnalité maximales du véhicule. C'est pourquoi nous vous invitons à suivre scrupuleusement le manuel de montage ou à vous adresser à votre revendeur agréé.

En cas de montage ou d'utilisation non conformes de ce produit, le (quasi) constructeur ou le fournisseur déclinent toute responsabilité.
Merci !

15 ESPAÑOL

Le agradecemos que se haya decidido por este producto.

Este producto de alta calidad está probado para la competición y se ha desarrollado específicamente para las exigencias de este deporte. Para poder garantizar los máximos niveles de seguridad y funcionalidad, es imprescindible que el producto se monte correctamente. Por este motivo, es muy importante que siga las instrucciones del manual de montaje o que se ponga en contacto con su concesionario autorizado.

El (cuasi) fabricante y el proveedor de este producto no se harán responsables del montaje y el uso incorrectos.
¡Muchas gracias!

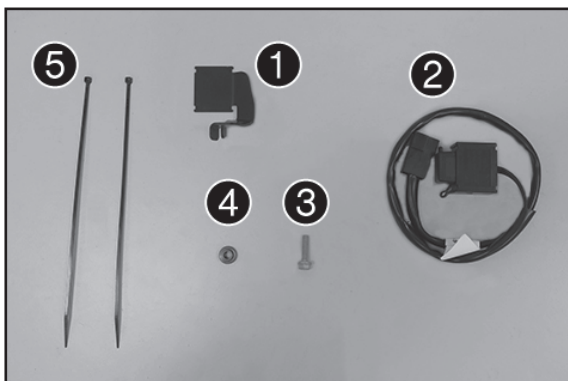

Lieferumfang

- 1x Halteblech ①
- 1x USB Steckdose 12V ②
- 1x Bundschraube M5x20 ③
- 1x Buchse ④
- 2x Kabelband ⑤

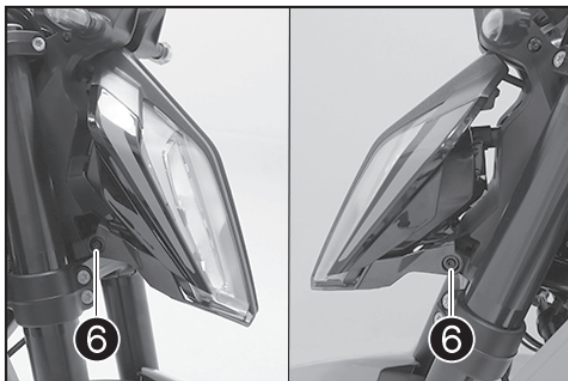

Montage

- Zündung ausschalten.
- Schrauben ⑥ entfernen.

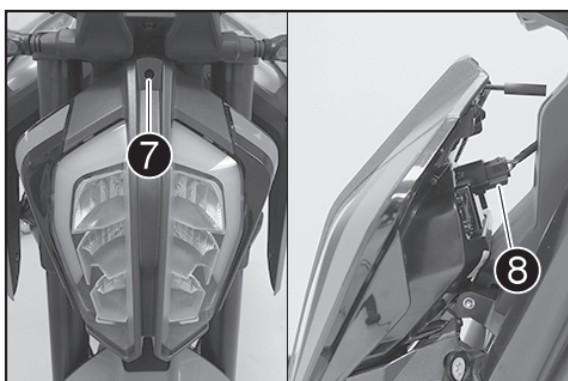

- Einstellschraube ⑦ komplett herausdrehen.

HINWEIS

Die Einstellschraube ist durch eine Kugelkopfhalterung an der Scheinwerfermaske befestigt.
Die Einstellschraube nicht aus der Kugelkopfhalterung ziehen.

- Scheinwerfermaske leicht nach vorn schwenken und Stecker ⑧ abstecken.
- Scheinwerfer abnehmen.

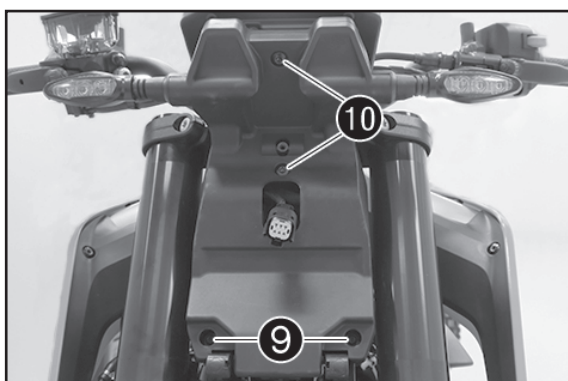

- Schrauben ⑨ entfernen.
- Schrauben ⑩ entfernen.
- Schrauben ⑪ entfernen.

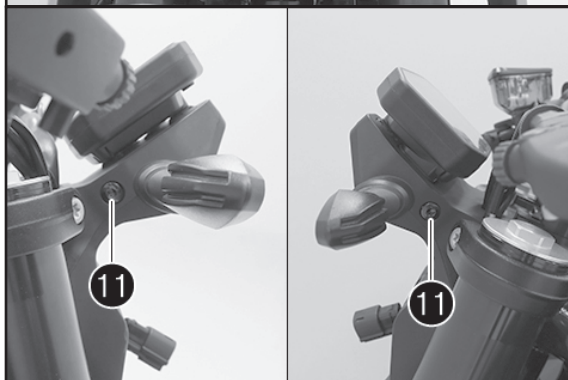

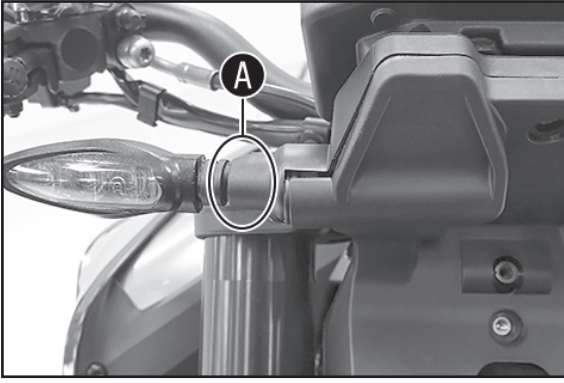

- Blinker im Bereich **A** greifen und vorsichtig entgegen der Fahrtrichtung drücken.

✓ Die Abdeckung löst sich wie im Bild ersichtlich.

- Arbeitsschritt auf der gegenüberliegenden Seite wiederholen.
- Abdeckung entfernen.

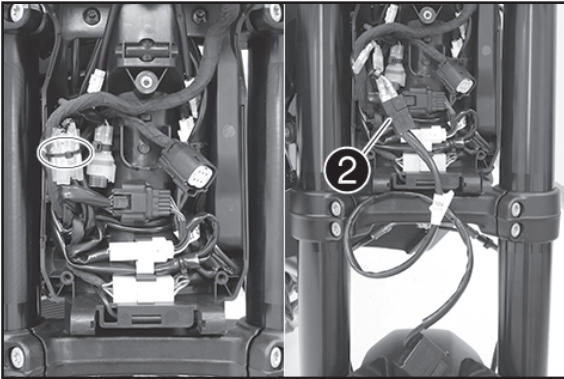

- Kabelbinder entfernen.

- Kabel der USB Steckdose **2** (Lieferumfang) am ACC2 Kabel anschließen.

ACC2 - Strom über Zündung

HINWEIS

Die ACC Kabel sind mit ACC1 und ACC2 gekennzeichnet. Gegebenenfalls muss der Steckerschutz gekürzt werden.

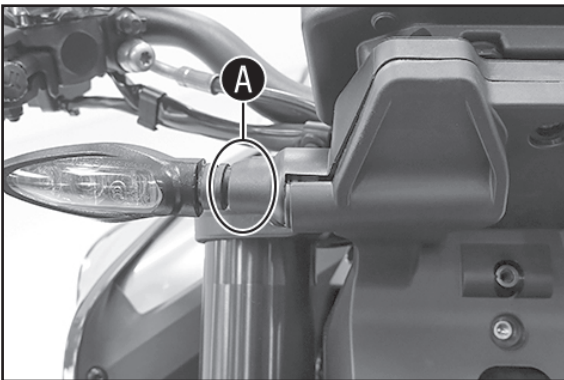

- Stecker spannungsfrei verlegen und mit Kabelbinder sichern.

- Abdeckung positionieren, dabei die Steckerverbindung des Scheinwerfers und die USB Steckdose mit Kabel durch die Öffnung führen.

- Blinker im Bereich **A** greifen und vorsichtig entgegen der Fahrtrichtung drücken, gleichzeitig die Abdeckung festdrücken.

✓ Abdeckung rastet mit einem hörbaren Klicken ein.

- Arbeitsschritt auf der gegenüberliegenden Seite wiederholen.

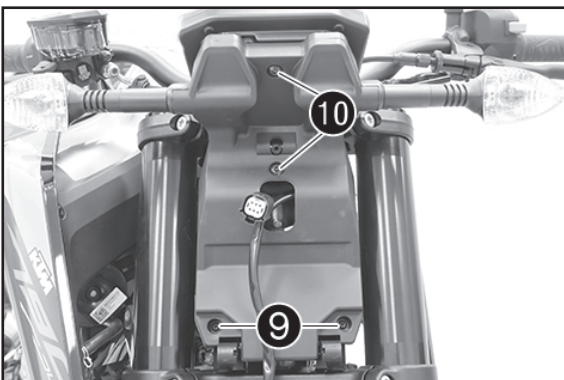

- Schrauben **10** montieren und mit 5 Nm festziehen.

- Schrauben **9** montieren und mit 2 Nm festziehen.

- Schraube **11** links montieren und mit 5 Nm festziehen.



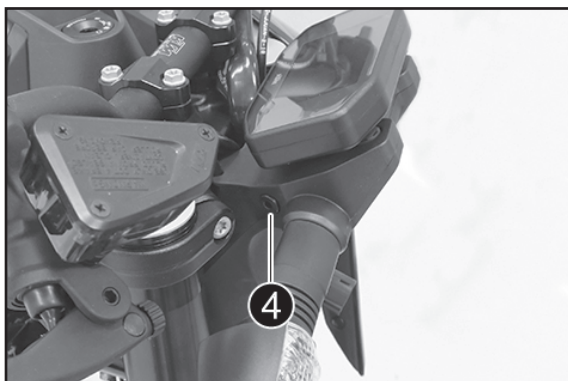

- Buchse ④ (Lieferumfang) rechts montieren.

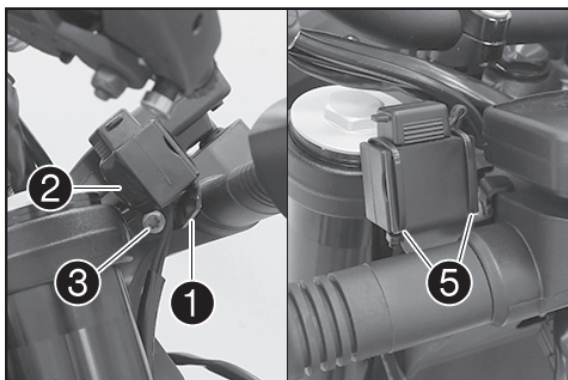

- Halteblech ① mit Schraube ③ (beides Lieferumfang) montieren.
- Schraube ③ mit 5 Nm festziehen.
- USB Steckdose ② auf dem Halteblech positionieren.
- Kabelbinder ⑤ (Lieferumfang) montieren und festziehen.

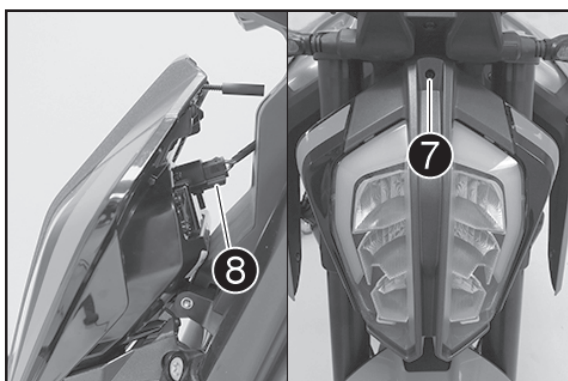

- Stecker ② anstecken.
- Scheinwerfermaske positionieren.
- Einstellschraube ⑦ montieren.

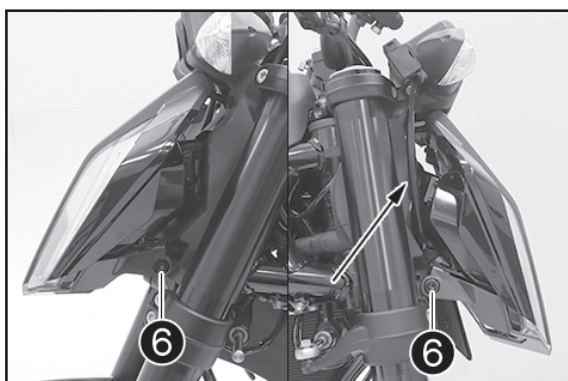

- Schrauben ⑥ montieren und mit 2 Nm festziehen.
- Kabel der USB Steckdose hinter dem Scheinwerfer positionieren und ggf. mit Kabelbinder sichern.

Nacharbeit

- Scheinwerfereinstellung kontrollieren (s. Bedienungsanleitung).
- Leuchtweite des Scheinwerfers einstellen (s. Bedienungsanleitung).
- Funktion der Beleuchtung kontrollieren.

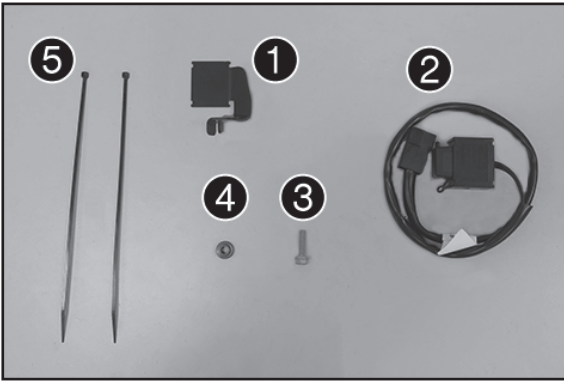

Scope of supply

- 1x retaining bracket ①
- 1x 12-V USB power socket ②
- 1x collar screw M5x20 ③
- 1x bushing ④
- 2x cable tie ⑤

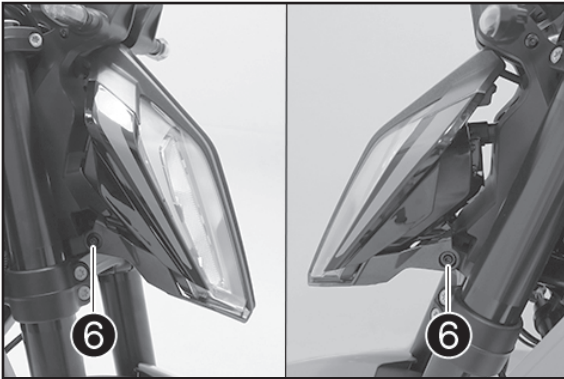

Assembly

- Switch off the ignition system.
- Remove screws ⑥.

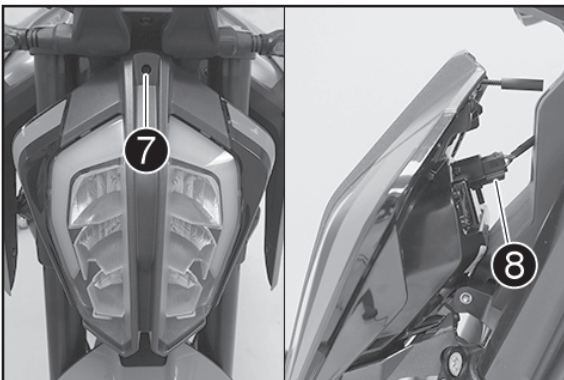

- Completely unscrew adjusting screw ⑦.

NOTE

The adjusting screw is fastened to the headlight mask by a ball head holder.
Do not pull the adjusting screw out of the ball head adjuster.

- Swivel the headlight mask slightly forwards and disconnect socket connector ⑧.
- Take off the headlight.

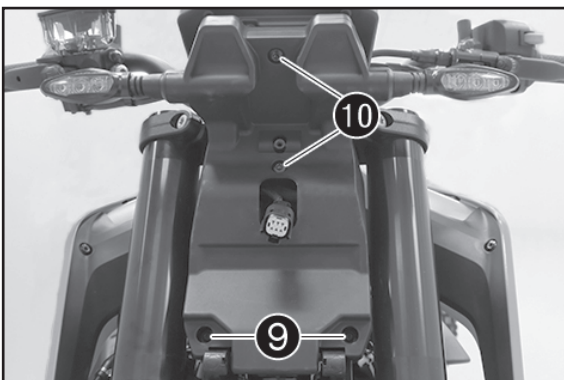

- Remove screws ⑨.
- Remove screws ⑩.
- Remove screws ⑪.

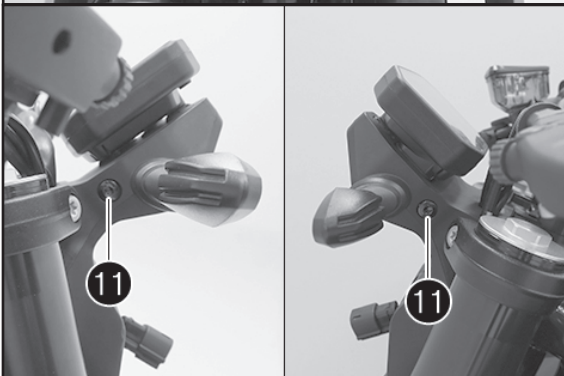

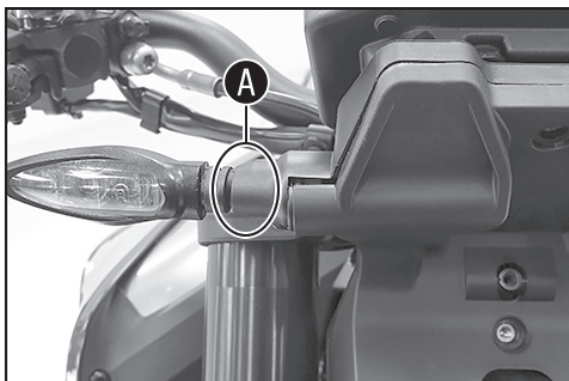

- Hold turn signal in area **A** and carefully press against the direction of travel.

✓ The cover is detached as illustrated.

- Repeat the operation on the opposite side.
- Remove the cover.

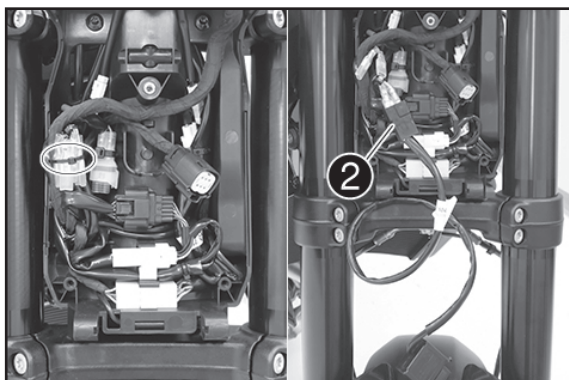

- Remove the cable tie.
- Connect cable of USB power socket **2** (included) to the ACC2 cable.

ACC2 – current via ignition system

NOTE

The ACC cables are labeled ACC1 and ACC2.
The connector guard may need to be shortened.

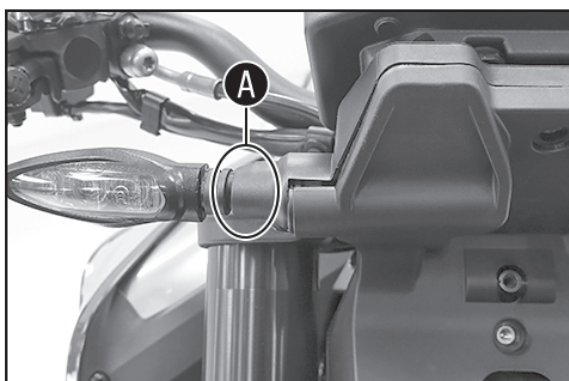

- Route the socket connector without tension and secure with a cable tie.
- Position the cover, guiding the headlight plug-in connector and USB power socket through the opening with the cable.
- Hold turn signal in the area **A** and carefully press against the direction of travel, while pressing the cover tight at the same time.

✓ The cover engages with an audible click.

- Repeat the operation on the opposite side.

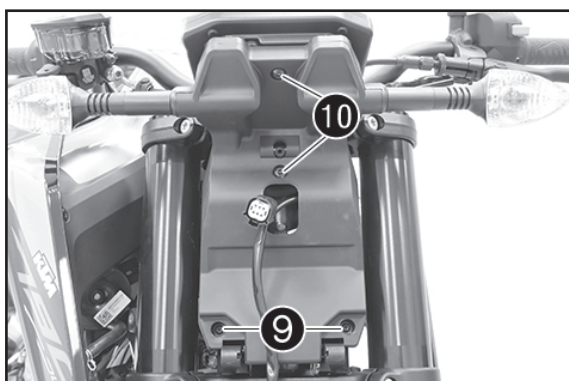

- Mount screws **10** and tighten to 5 Nm.
- Mount screws **9** and tighten to 2 Nm.
- Mount left screw **11** and tighten to 5 Nm.



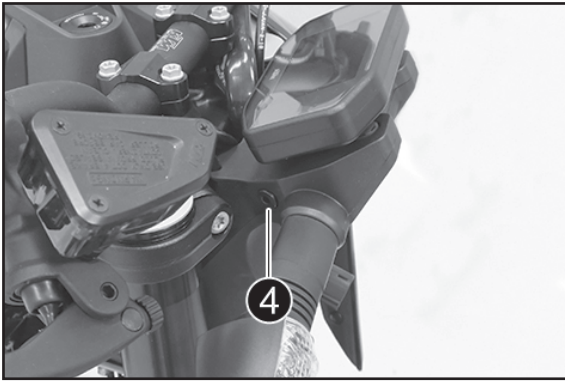

- Mount right bushing ④ (included).

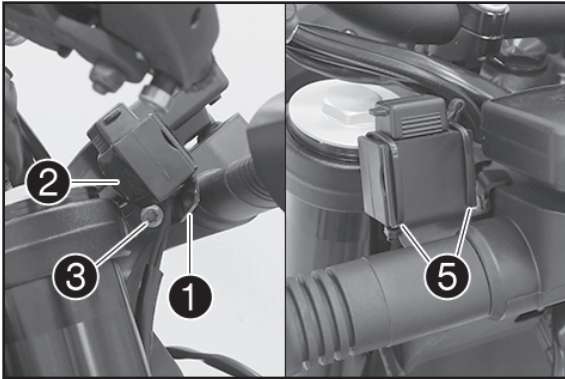

- Mount retaining bracket ① with screw ③ (both included).
- Tighten screw ③ to 5 Nm.
- Position USB power socket ② onto retaining bracket.
- Mount and tighten cable tie ⑤ (included).

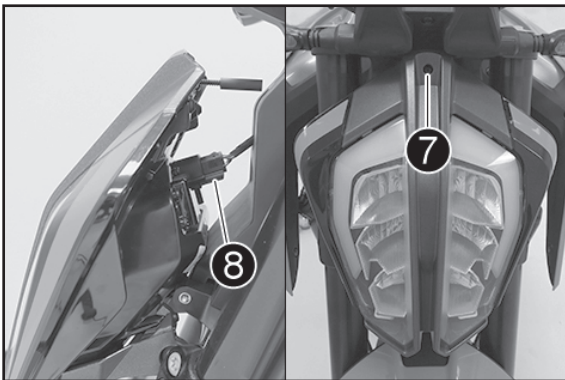

- Plug in socket connector ⑧.
- Position the headlight mask.
- Mount adjusting screw ⑦.

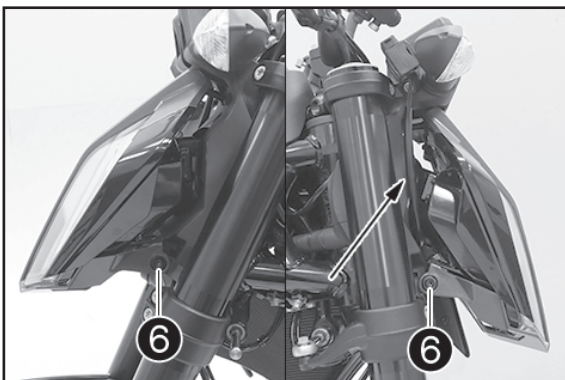

- Mount screws ⑥ and tighten to 2 Nm.
- Position the cable of USB power socket behind the headlight and if necessary secure with a cable tie.

Final steps

- Check headlight setting (see Owner's Manual).
- Adjust headlight range of the headlight (see Owner's Manual).
- Check that the lighting is functioning properly.

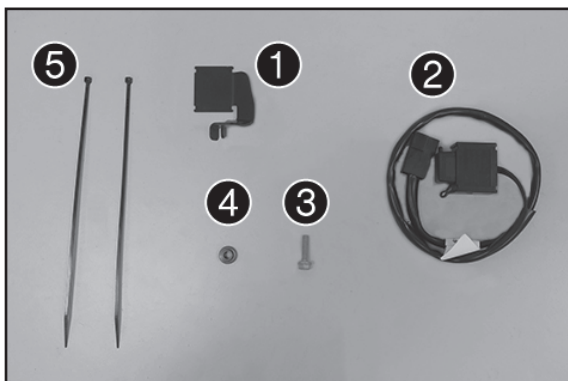

Materiale fornito

- 1 piastrina ①
- 1 presa USB a 12 V ②
- 1 vite flangiata M5x20 ③
- 1 boccola ④
- 2 fascette ⑤

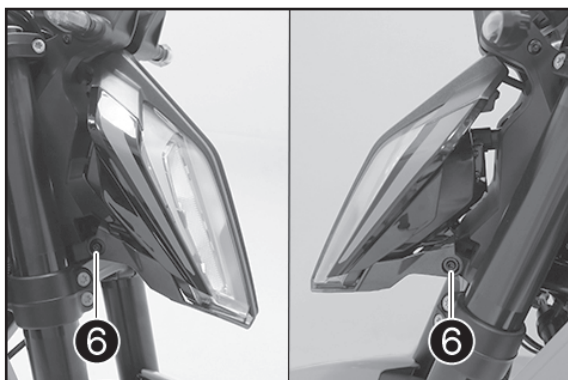

Montaggio

- Disinserire il sistema d'accensione.
- Rimuovere le viti ⑥.

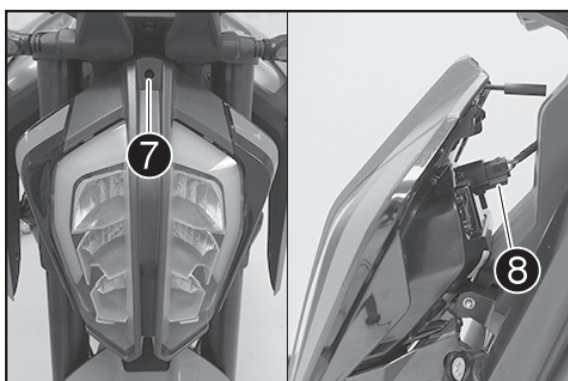

- Svitare completamente la vite di regolazione ⑦.

AVVERTENZA

La vite di regolazione è fissata alla mascherina portafaro per mezzo di un supporto a testa sferica.
Non estrarre la vite di regolazione dal supporto a testa sferica.

- Ruotare la mascherina portafaro leggermente in avanti e scollegare il connettore ⑧.
- Rimuovere il faro.

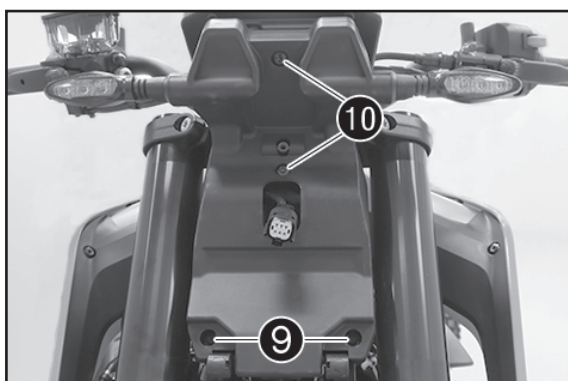

- Rimuovere le viti ⑨.
- Rimuovere le viti ⑩.
- Rimuovere le viti ⑪.

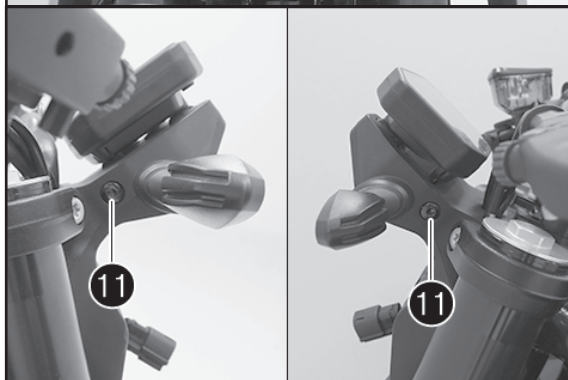

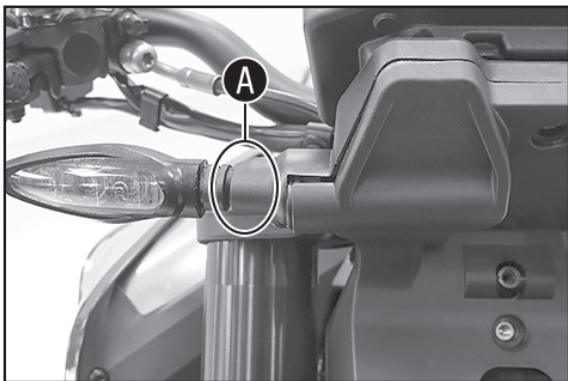

- Afferrare l'indicatore di direzione nella zona **A** e spingerlo con cautela in senso opposto alla direzione di marcia.

✓ La copertura si sgancia come si vede nella figura.

- Ripetere la fase di lavoro sul lato opposto.
- Rimuovere la copertura.

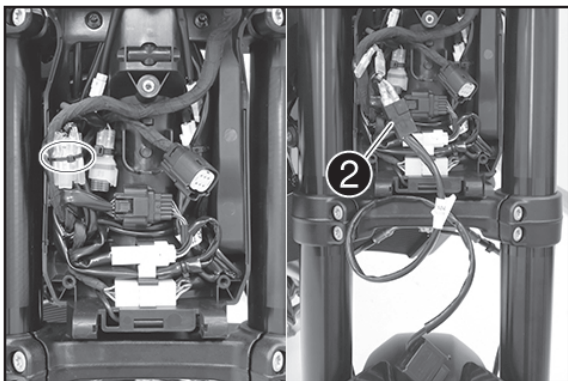

- Rimuovere la fascetta.
- Collegare il cavo della presa USB **2** (in dotazione) al cavo ACC2.

ACC2 - corrente attraverso l'accensione

AVVISO

I cavi ACC sono contrassegnati con ACC1 e ACC2.
Se necessario accorciare la protezione del connettore.

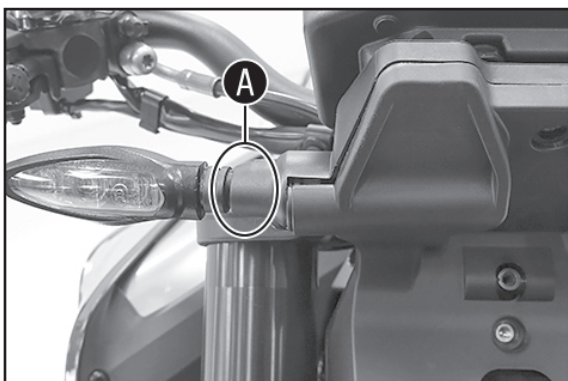

- Posizionare il connettore in modo che non presenti punti in tensione e assicurarlo con una fascetta.
- Posizionare la copertura e far passare il connettore del faro e la presa USB con il cavo attraverso l'apertura.
- Afferrare l'indicatore di direzione nella zona **A** e spingerlo con cautela in senso opposto alla direzione di marcia, contemporaneamente premere in sede la copertura.

✓ La copertura si innesta con un clic udibile.

- Ripetere la fase di lavoro sul lato opposto.

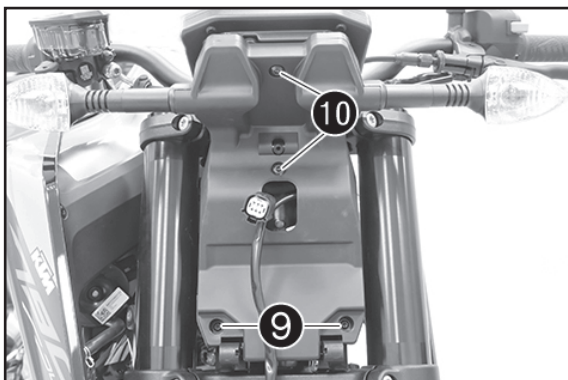

- Montare le viti **10** e serrarle a 5 Nm.

- Montare le viti **9** e serrarle a 2 Nm.

- Montare la vite **11** a sinistra e serrarla a 5 Nm.





- Montare la boccola ④ (in dotazione) a destra.

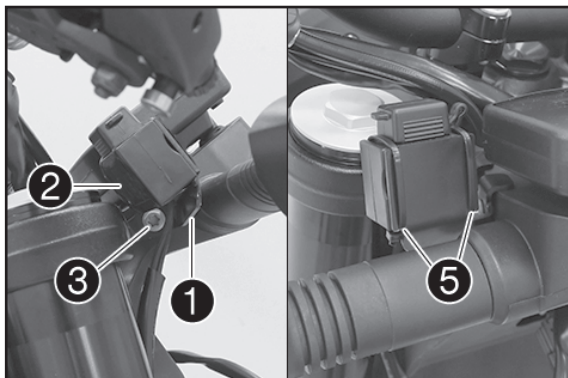

- Montare la piastrina ① con la vite ③ (entrambe in dotazione).
- Serrare la vite ③ a 5 Nm.
- Posizionare la presa USB ② sulla piastrina.
- Montare e serrare la fascetta ⑤ (in dotazione).

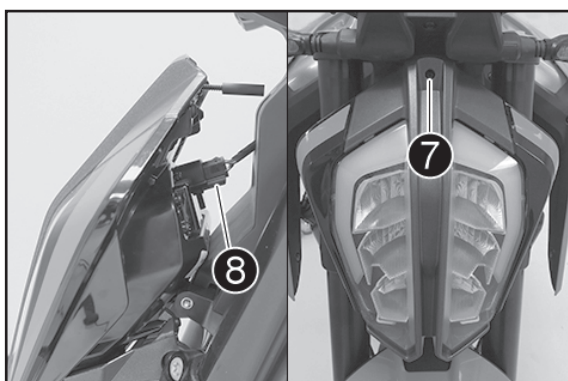

- Collegare il connettore ⑧.
- Posizionare la mascherina portafaro.
- Montare la vite di regolazione ⑦.

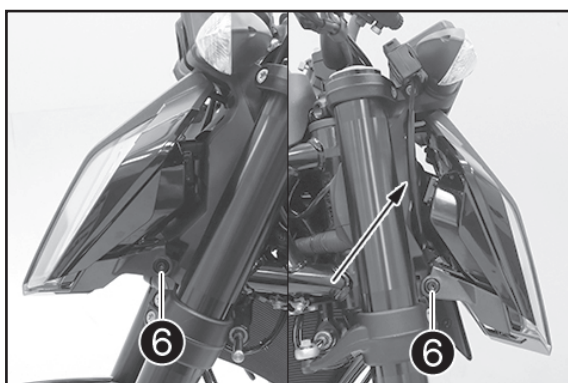

- Montare le viti ⑥ e serrarle a 2 Nm.
- Posizionare il cavo della presa USB dietro il faro e se necessario fissarlo con una fascetta.

Operazione conclusiva

- Controllare l'orientamento del faro (v. manuale d'uso).
- Regolare la profondità del fascio luminoso del faro (v. manuale d'uso).
- Controllare il funzionamento dell'illuminazione.

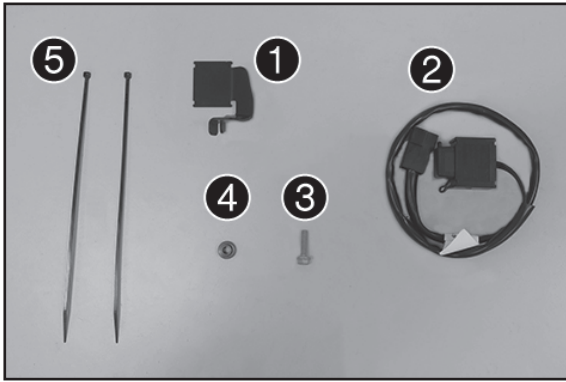

Contenu de la livraison

- 1x plaque de fixation ❶
- 1x prise USB 12 V ❷
- 1x vis à épaulement M5x20 ❸
- 1x bague ❹
- 2x rilsans ❺

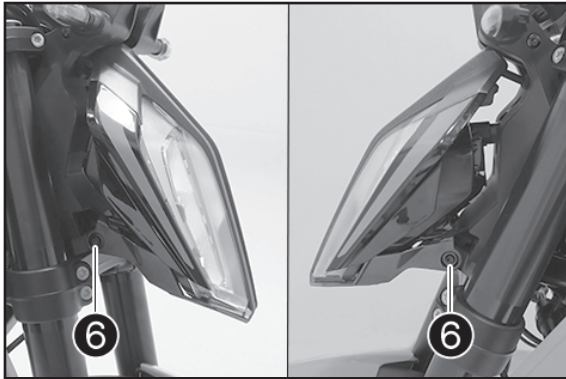

Montage

- Couper le contact.
- Retirer les vis ❹.

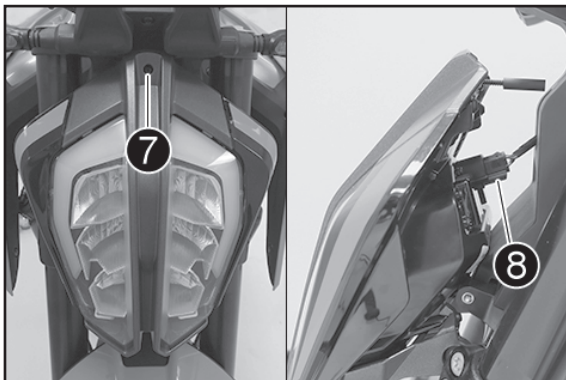

- Dévisser complètement la vis de réglage ❷.

REMARQUE

La vis de réglage est maintenue sur la plaque-phare par une fixation à tête de rotule.
Ne pas retirer la vis de réglage de la fixation à tête de rotule.

- Basculer la plaque-phare légèrement vers l'avant et débrancher le connecteur ❸.
- Déposer le phare.

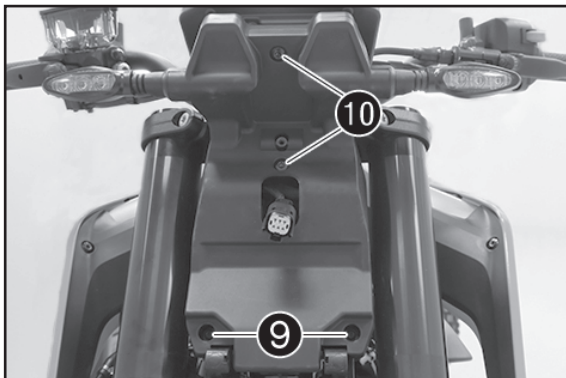

- Retirer les vis ❹.
- Retirer les vis ❺.
- Retirer les vis ❻.

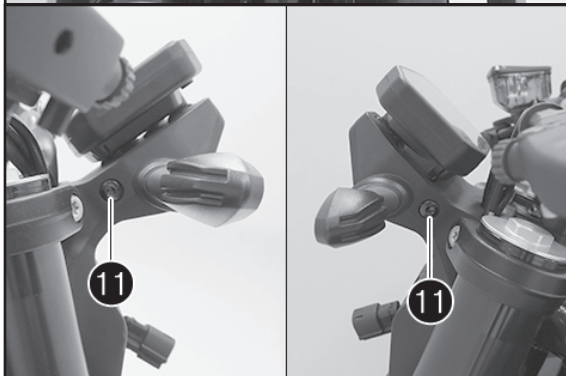

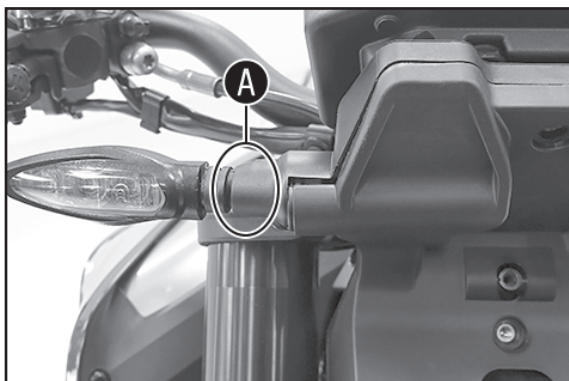

- Saisir le clignotant dans la zone **A** et appuyer avec précaution dans la direction opposée au sens de marche.

✓ Le cache se détache comme indiqué sur la figure.

- Répéter l'étape de travail du côté opposé.
- Déposer le cache.

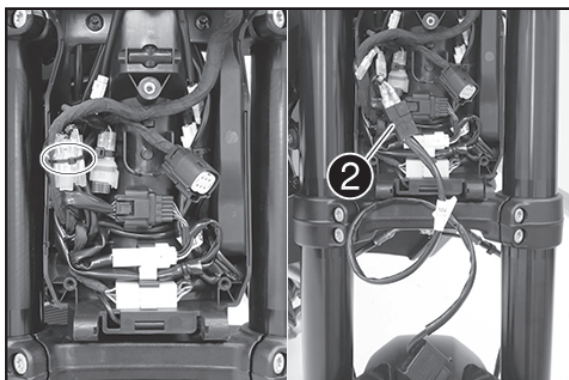

- Retirer le rilsan.
- Brancher le câble de la prise USB **2** (contenu de la livraison) au câble ACC2.

ACC2 - courant sur allumage

REMARQUE

Les câbles ACC sont marqués ACC 1 et ACC 2.
Raccourcir la protection de prise si nécessaire.

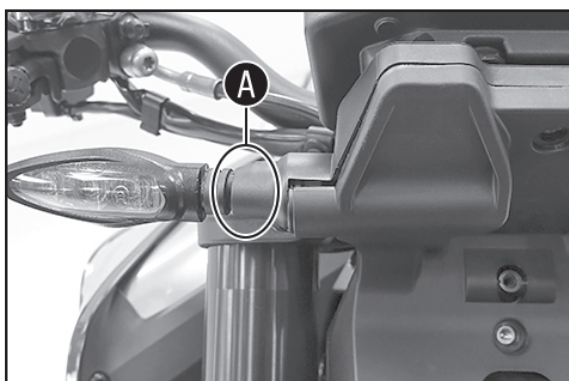

- Poser la prise de manière à ce qu'elle ne soit soumise à aucune contrainte et la fixer à l'aide d'un rilsan.
- Positionner le cache en passant le connecteur du phare et la prise USB avec son câble par l'ouverture.
- Saisir le clignotant dans la zone **A** et appuyer avec précaution dans la direction opposée au sens de marche tout en appuyant fermement sur le cache.

✓ L'emboîtement du cache est perceptible à l'oreille.

- Répéter l'étape de travail du côté opposé.

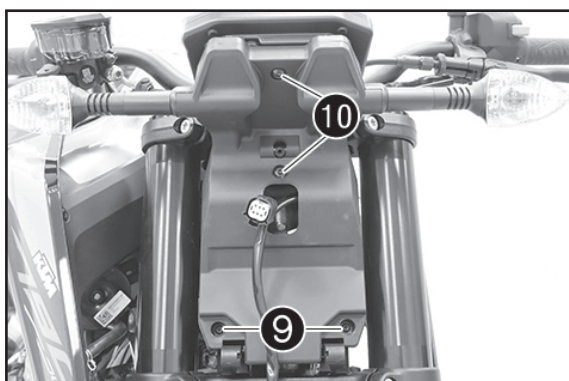

- Mettre en place les vis **10** et les serrer à 5 Nm.
- Mettre en place les vis **9** et les serrer à 2 Nm.
- Mettre en place la vis **11** sur le côté gauche et la serrer à 5 Nm.



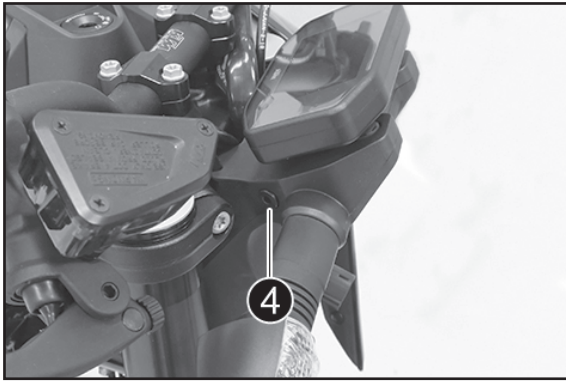

- Mettre en place la bague ④ (comprise dans la livraison) sur le côté droit.

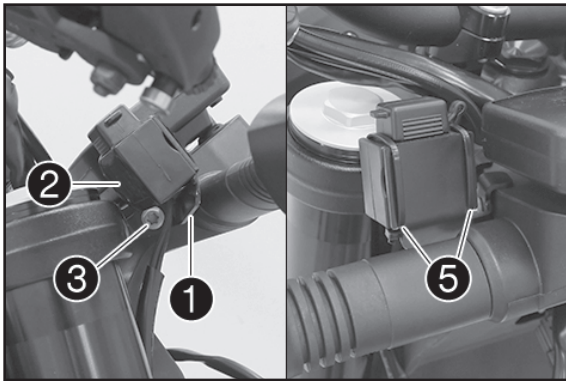

- Mettre en place la plaque de fixation ① et la vis ③ (toutes deux comprises dans la livraison).
- Serrer la vis ③ à 5 Nm.
- Positionner la prise USB ② sur la plaque de fixation.
- Mettre en place le rilsan ⑤ (compris dans la livraison) et le serrer.

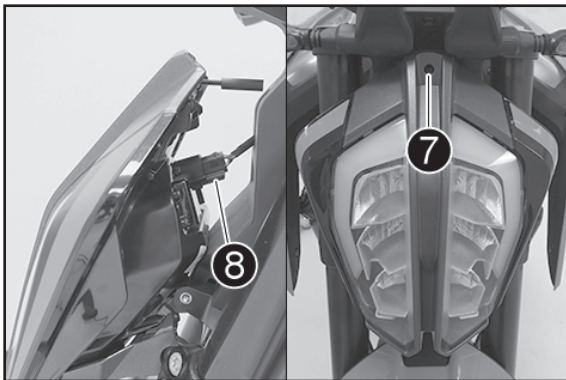

- Brancher le connecteur ⑧.
- Positionner la plaque-phare.
- Mettre en place la vis de réglage ⑦.

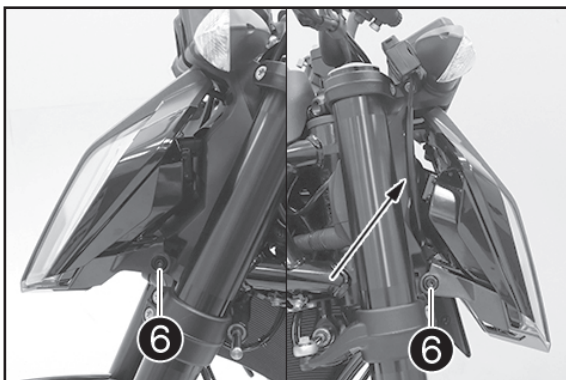

- Mettre en place les vis ⑥ et les serrer à 2 Nm.
- Positionner le câble de la prise USB derrière le phare et, si nécessaire, l'attacher avec un rilsan.

Travaux ultérieurs

- Contrôler le réglage du phare (voir le manuel d'utilisation).
- Régler la portée du phare (voir le manuel d'utilisation).
- Contrôler le fonctionnement de l'éclairage.

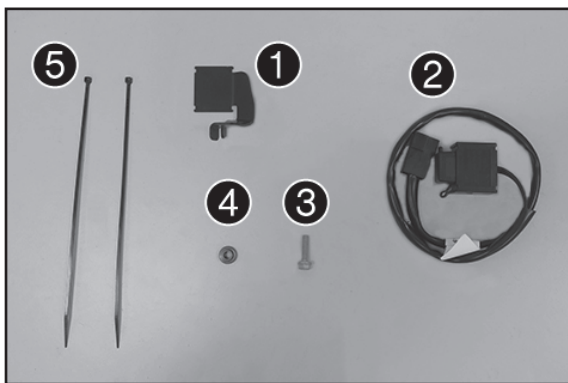

Volumen de suministro

- 1x retenedor ①
- 1x puerto USB de 12 V ②
- 1x tornillo de collarín M5x20 ③
- 1x casquillo ④
- 2x bridas ⑤

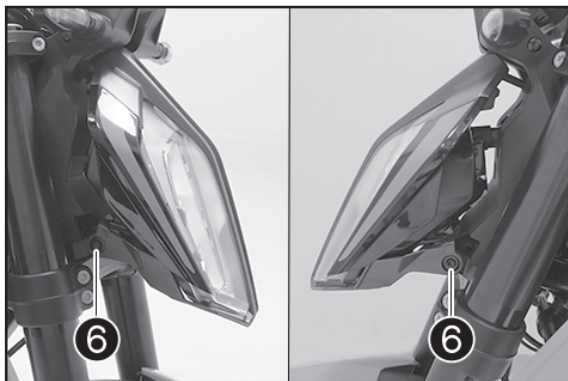

Montaje

- Desconectar el sistema de encendido.
- Retirar los tornillos ⑥.

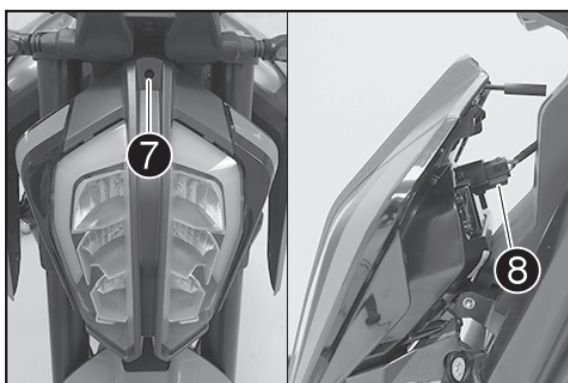

- Extraer completamente el tornillo de ajuste ⑦.

AVISO

El mando de ajuste está sujeto mediante un soporte de rótula a la máscara de faro.
No sacar el mando de ajuste del soporte de rótula.

- Abatir la máscara de faro ligeramente hacia delante y desconectar la clema ⑧.
- Quitar el faro.

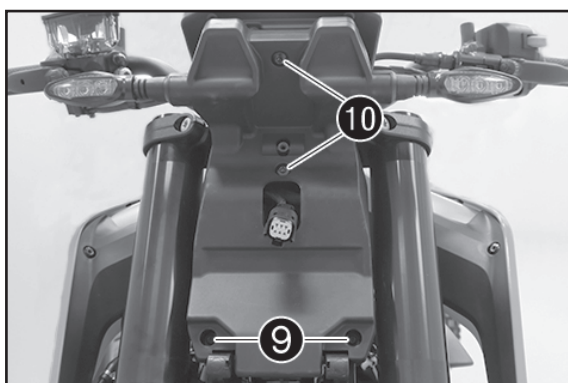

- Retirar los tornillos ⑨.
- Retirar los tornillos ⑩.
- Retirar los tornillos ⑪.

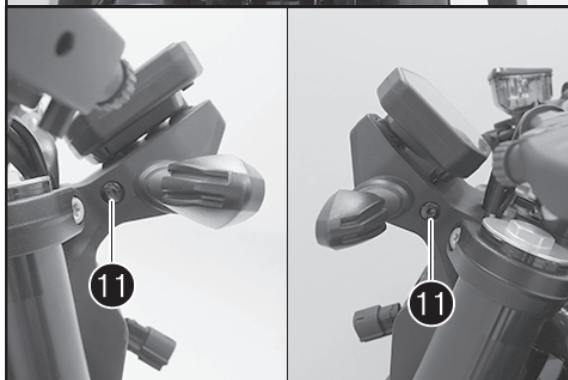

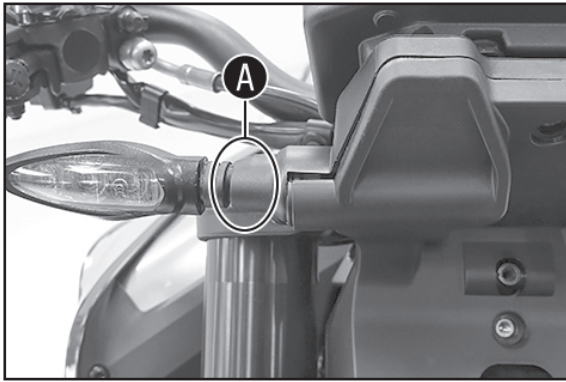

- Sujetar el intermitente en la zona **A** y empujarlo con cuidado en contra de la dirección de marcha.

✓ La tapa se suelta como se muestra en la imagen.

- Repetir el paso de trabajo en el lado opuesto.
- Retirar la tapa.

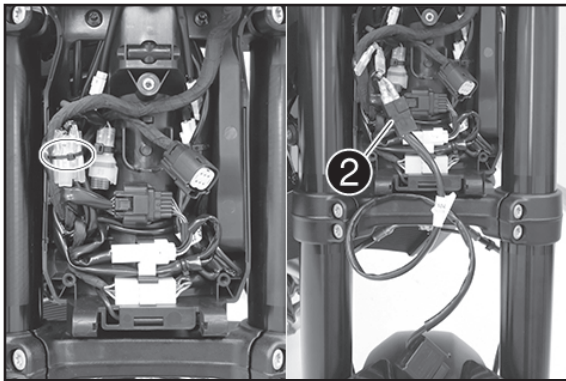

- Retirar las bridas.
- Conectar el cable del puerto USB **2** (volumen de suministro) al cable ACC2.

ACC2: corriente a través del sistema de encendido

AVISO

Los cables ACC están marcados con ACC1 y ACC2.

En caso necesario deberá acortarse la protección de la clema.

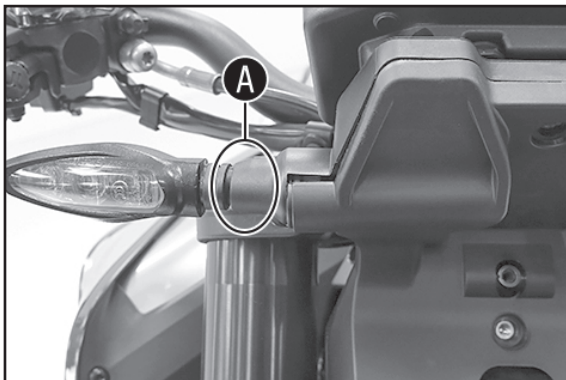

- Colocar la clema sin tensiones y asegurarla con una brida.
- Colocar la tapa introduciendo el conector del faro y el puerto USB con cable a través de la abertura.

- Sujetar el intermitente en la zona **A** y empujarlo con cuidado en contra de la dirección de marcha, a la vez que se aprieta la tapa.

✓ La tapa se enclava de manera audible.

- Repetir el paso de trabajo en el lado opuesto.

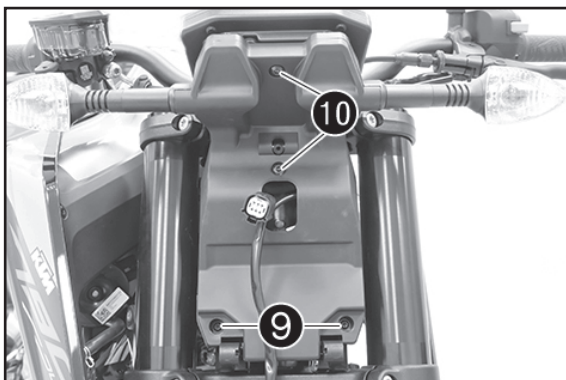

- Montar los tornillos **10** y apretarlos a 5 Nm.
- Montar los tornillos **9** y apretarlos a 2 Nm.
- Montar el tornillo **11** a la izquierda y apretarlo a 5 Nm.



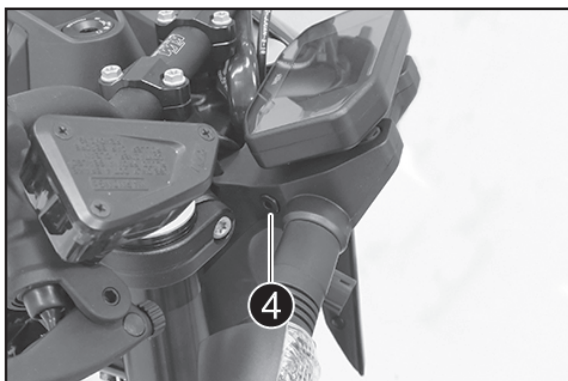

- Montar el casquillo ④ (volumen de suministro) a la derecha.

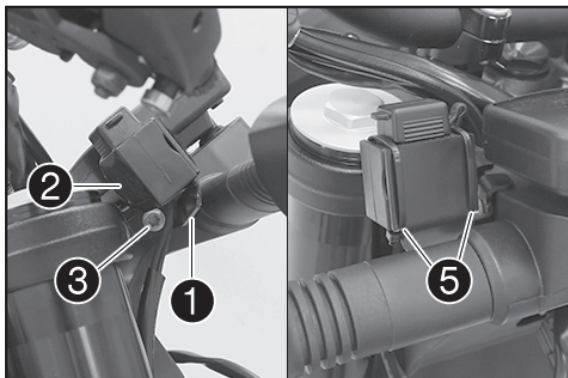

- Montar el retenedor ① con el tornillo ③ (ambos incluidos en el volumen de suministro).
- Apretar el tornillo ③ a 5 Nm.
- Posicionar el puerto USB ② en el retenedor.
- Montar y apretar la brida ⑤ (volumen de suministro).

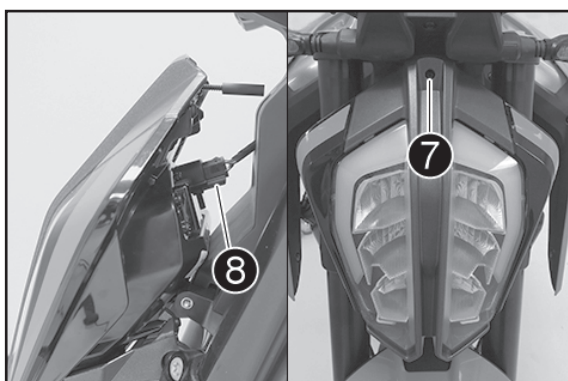

- Enchufar la clema ⑧.
- Colocar la máscara de faro.
- Montar el tornillo de ajuste ⑦.

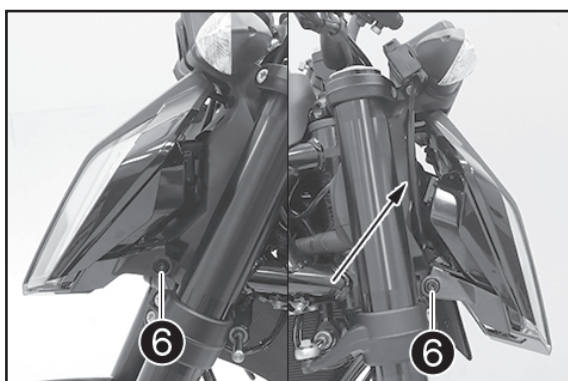

- Montar los tornillos ⑥ y apretarlos a 2 Nm.
- Posicionar el cable del puerto USB detrás del faro y, si es necesario, asegurarlo con bridas.

Trabajos posteriores

- Comprobar el ajuste del faro (véase el manual de instrucciones).
- Ajustar la distancia de alumbrado del faro (véase el manual de instrucciones).
- Comprobar el funcionamiento del alumbrado.