

9050293114430  
90502931244C1

# HUSQVARNA MOTORCYCLES ACCESSORIES INFORMATION

CLUTCH LEVER ARTICULATED AND ADJUSTABLE

04.2019  
3.402.229



Husqvarna Motorcycles GmbH  
Stallhofnerstraße 3  
5230 Mattighofen, Austria

T: +43/7742/6000-0  
W: [www.husqvarna-motorcycles.com](http://www.husqvarna-motorcycles.com)



## 3 DEUTSCH

Wir freuen uns, dass Sie sich für dieses Produkt entschieden haben.

Unser hochwertiges Qualitätsprodukt ist rennerprobt und wurde speziell für sportliche Herausforderungen entwickelt. Eine korrekte Montage des Produktes ist unerlässlich, um ein Maximum an Sicherheit und Funktionalität gewährleisten zu können. Bitte befolgen Sie daher die Montageanleitung oder wenden Sie sich an Ihren autorisierten Fachhändler.

**Für falsche Montage oder Verwendung dieses Produktes kann der (Quasi-)Hersteller bzw. Lieferant nicht zur Verantwortung gezogen werden.**

Vielen Dank.

## 5 ENGLISH

Thank you for choosing this product.

Our high quality product has been tested under racing conditions and was developed specifically for use in sports activities. Correct installation of the product is essential to ensure that a maximum degree of safety and functionality is achieved. Therefore, please follow the installation instructions or contact your authorized dealer.

**The (quasi) manufacturer or supplier cannot be held responsible for products that are incorrectly mounted or inappropriately used.**

Thank you.

## 7 ITALIANO

Grazie per aver scelto questo prodotto.

Questo nostro prodotto di pregiata qualità è collaudato nelle competizioni ed è stato sviluppato specificamente per gare sportive. Il montaggio corretto del prodotto è fondamentale per garantirne la massima sicurezza e funzionalità. Rispetti quindi le istruzioni di montaggio o rivolgerti al proprio concessionario autorizzato.

**Il produttore (detentore del marchio)/fornitore non può essere considerato responsabile per un montaggio o impiego errato del presente prodotto.**

Vi ringraziamo per l'attenzione!

## 9 FRANÇAIS

Merci d'avoir porté votre choix sur ce produit.

Notre produit de haute qualité est éprouvé pour les compétitions et a été conçu spécialement pour un usage sportif. Un montage approprié du produit est indispensable pour garantir une sécurité et une fonctionnalité maximales du véhicule. C'est pourquoi nous vous invitons à suivre scrupuleusement le manuel de montage ou à vous adresser à votre revendeur agréé.

**En cas de montage ou d'utilisation non conformes de ce produit, le (quasi) constructeur ou le fournisseur déclinent toute responsabilité.**

Merci !

## 11 ESPAÑOL

Le agradecemos que se haya decidido por este producto.

Este producto de alta calidad está probado para la competición y se ha desarrollado específicamente para las exigencias de este deporte. Para poder garantizar los máximos niveles de seguridad y funcionalidad, es imprescindible que el producto se monte correctamente. Por este motivo, es muy importante que siga las instrucciones del manual de montaje o que se ponga en contacto con su concesionario autorizado.

**El (cuasi) fabricante y el proveedor de este producto no se harán responsables del montaje y el uso incorrectos.**

¡Muchas gracias!

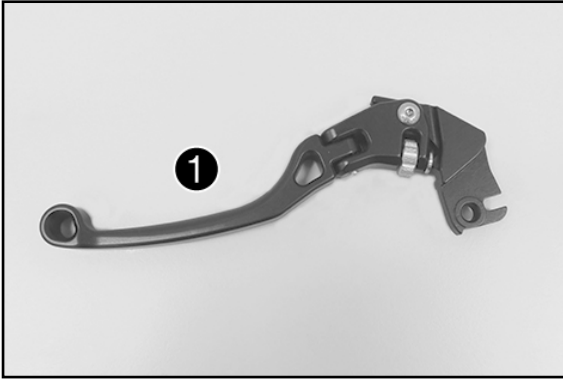

## Lieferumfang

1x Klappbarer Kupplungshebel ❶

## HINWEIS

Sämtliche Schrauben und Muttern werden vom Originalhebel wiederverwendet.  
Vor der Montage müssen diese Teile gründlich gereinigt und gegebenenfalls gefettet werden.

## Montage

- Verschraubung ❷ entfernen.
- Manschette ❸ zurückschieben.

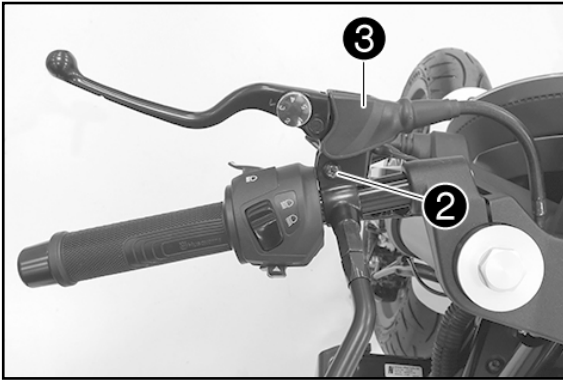

- Schrauben ❹ entfernen.
- Kupplungsschalter zur Seite hängen.

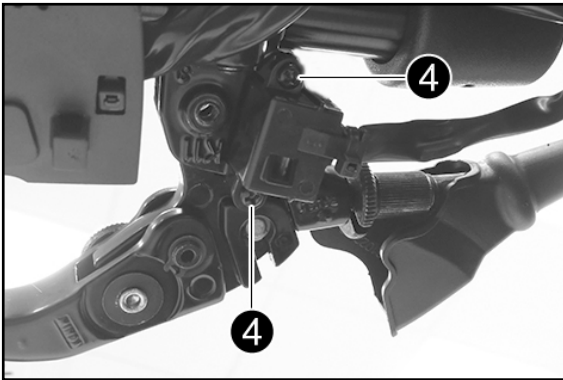

- Kupplungsseil ❺ aushängen.

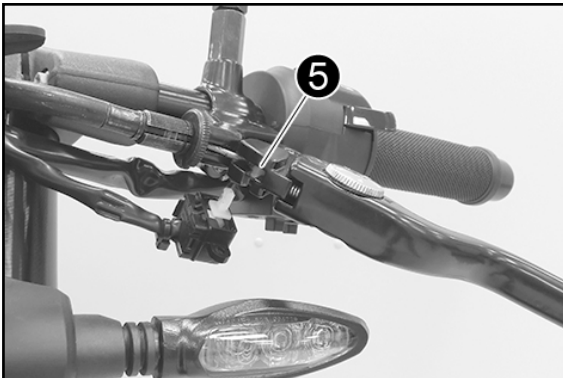

- Kupplungsschalter positionieren.
- Schrauben ❹ montieren und festziehen.

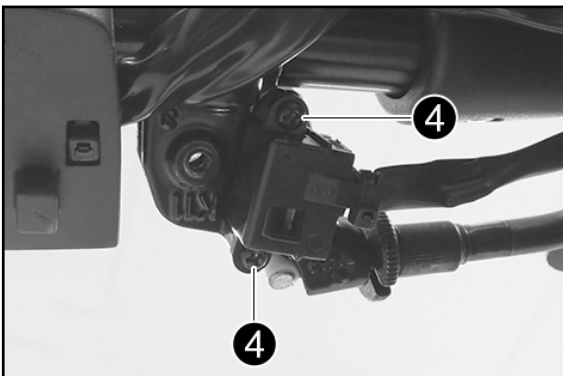

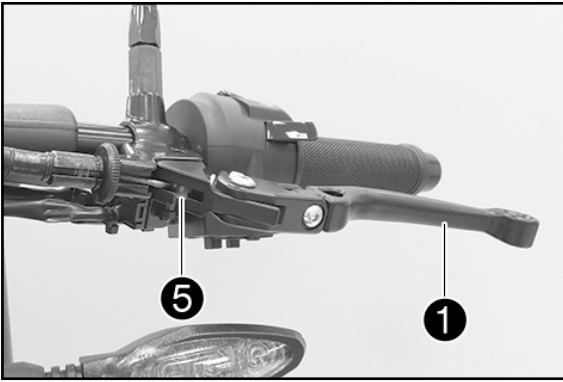

- Kupplungshebel ① (Lieferumfang) positionieren.
- Kupplungsseil ⑤ einhängen.

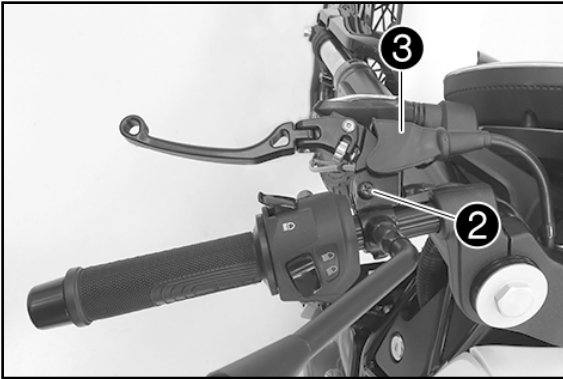

- Verschraubung ② montieren und mit 8 Nm festziehen.
- Manschette ③ positionieren.

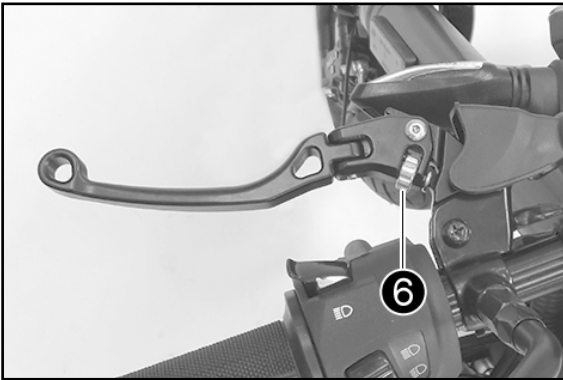

- Grundstellung des Kupplungshebels mit dem Einstellrad ⑥ an die Handgröße anpassen.

#### HINWEIS

Handbremshebel nach vorn drücken und Einstellrad drehen.  
Einstellarbeiten nicht während der Fahrt durchführen.

#### **! VORSICHT**

**Auf eine korrekte Montage der Hebel achten!**  
**Vor der ersten Benutzung unbedingt die Funktionstüchtigkeit der Kupplung überprüfen!**

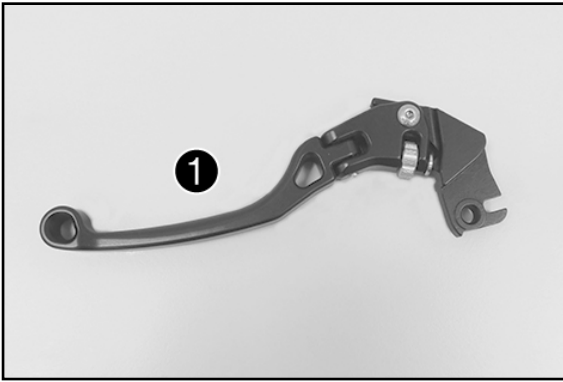

### Scope of supply

1x clutch lever ①

### NOTE

All screws and nuts from the original lever can be re-used.  
Before assembly, these parts must be cleaned thoroughly and, if necessary, greased.

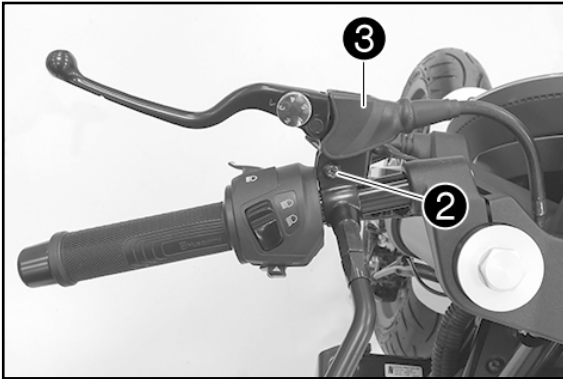

### Assembly

- Remove fitting ②.
- Push back sleeve ③.

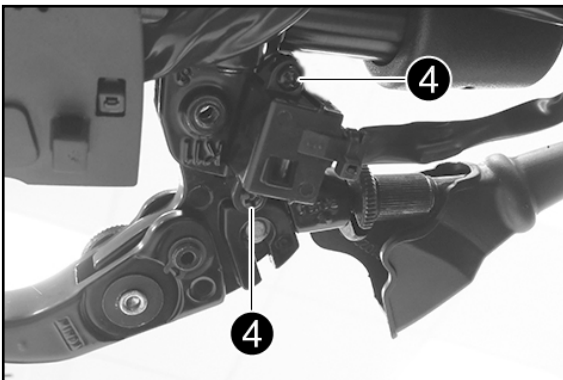

- Remove screws ④.
- Hang the clutch switch to the side.

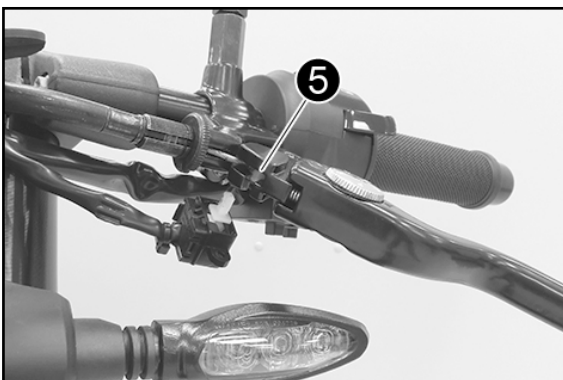

- Detach clutch cable wire ⑤.

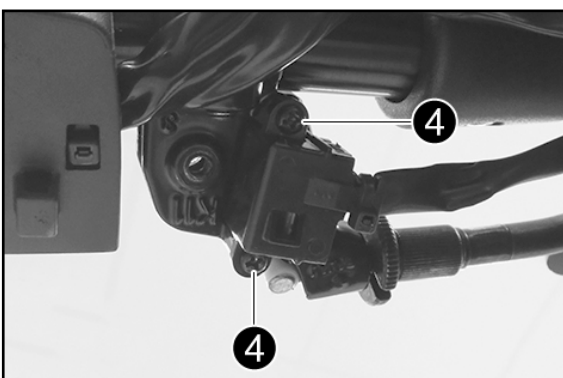

- Position clutch switch.
- Mount and tighten screws ④.

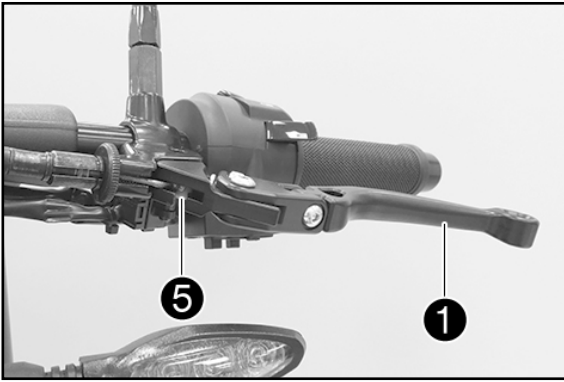

- Position clutch lever **1** (included).
- Attach clutch cable wire **5**.

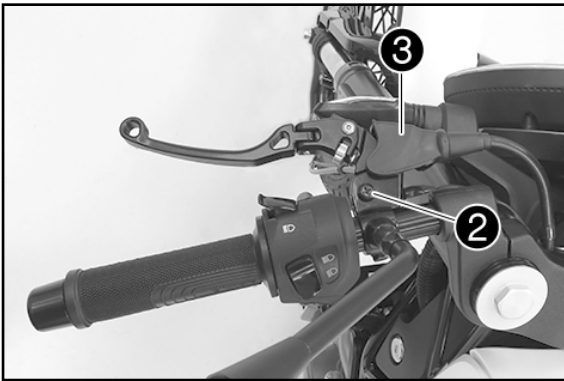

- Mount fitting **2** and tighten to 8 Nm.
- Position sleeve **3**.

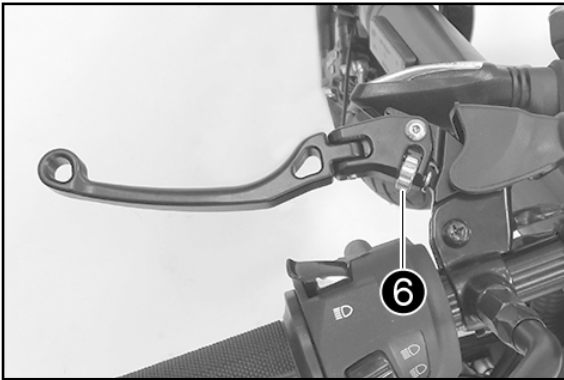

- Adjust the basic position of the clutch lever to your hand size by turning setting wheel **6**.

#### NOTE

Push the handbrake lever forward and turn the setting wheel.  
Do not make any adjustments while riding.

#### **!** ATTENTION

**Ensure that the lever is assembled correctly!**  
**Ensure that the clutch is functioning correctly before using it for the first time.**

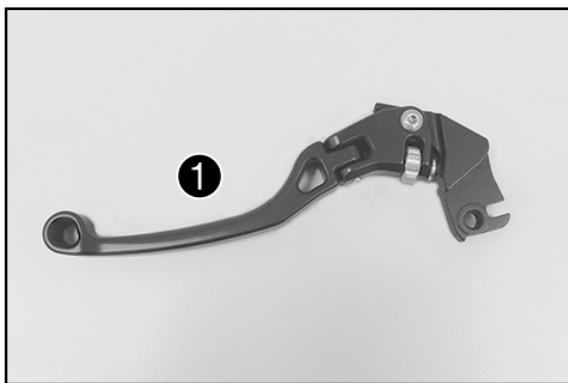

### Materiale fornito

1 leva della frizione ❶

### NOTA BENE

Riutilizzare tutte le viti e i dadi della leva originale.

Prima di procedere al montaggio, pulire a fondo questi componenti e, se necessario, ingrassarli.

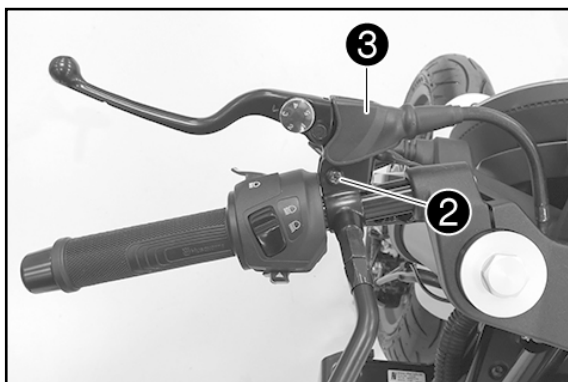

### Montaggio

- Rimuovere il collegamento a vite ❷.
- Spingere indietro la cuffia ❸.

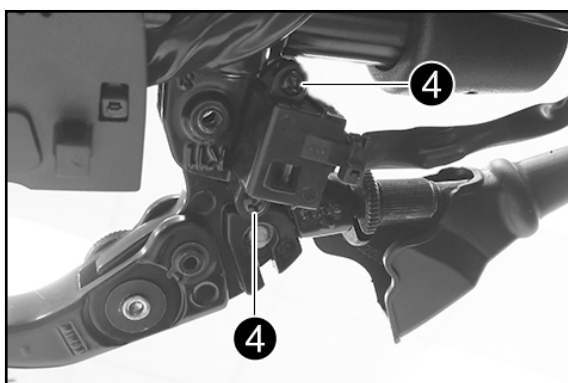

- Rimuovere le viti ❹.
- Agganciare di lato l'interruttore della frizione.



- Disimpegnare il cavo della frizione ❺.

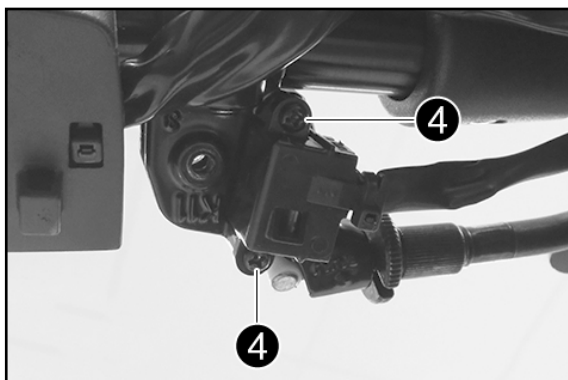

- Posizionare l'interruttore della frizione.
- Montare e serrare le viti ❹.

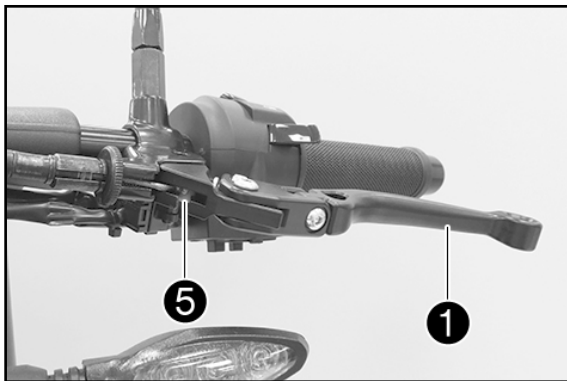

- Posizionare la leva della frizione ① (in dotazione).
- Agganciare il cavo della frizione ⑤.

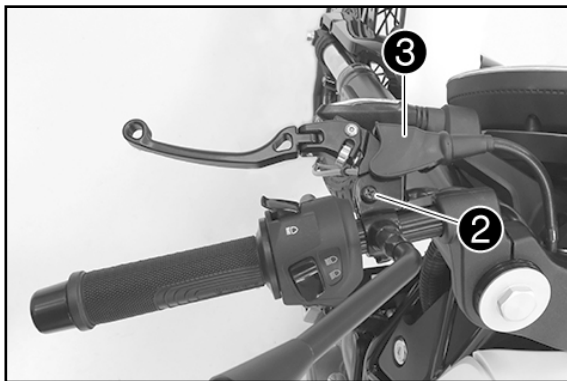

- Montare il collegamento a vite ② e serrarlo a 8 Nm.
- Posizionare la cuffia ③.

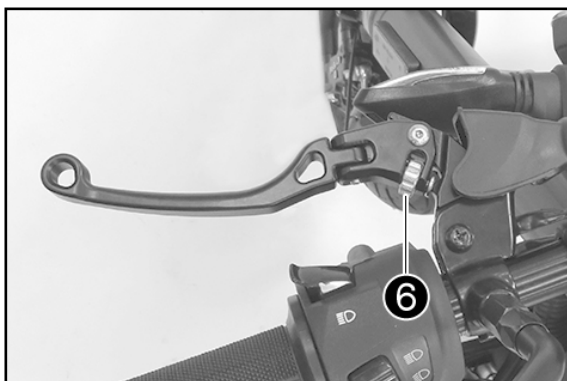

- Adattare la posizione a riposo della leva della frizione con la rondella di regolazione ⑥ in modo da avere una buona presa.

#### NOTA BENE

Spingere in avanti la leva del freno anteriore e ruotare la rondella di regolazione.

Non eseguire interventi di regolazione durante la marcia.

#### ! AVVERTIMENTO

**Prestare attenzione a montare correttamente la leva!**

**Prima del primo utilizzo verificare assolutamente il corretto funzionamento della frizione!**



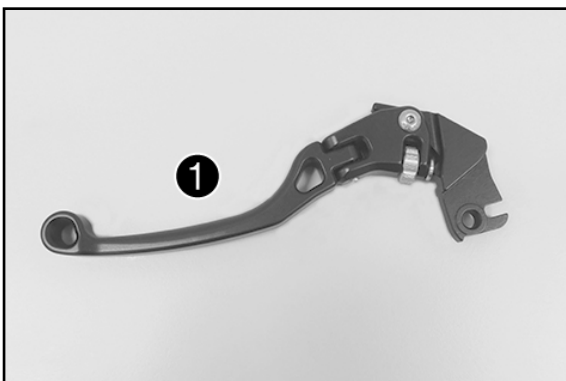

### Contenu de la livraison

1x levier d'embrayage ①

### REMARQUE

Toutes les vis et écrous du levier d'origine sont réutilisés.  
Avant le montage, ces pièces doivent être nettoyées minutieusement et graissées si nécessaire.

### Montage

- Retirer le raccord vissé ②.
- Repousser le cache-pousière ③.

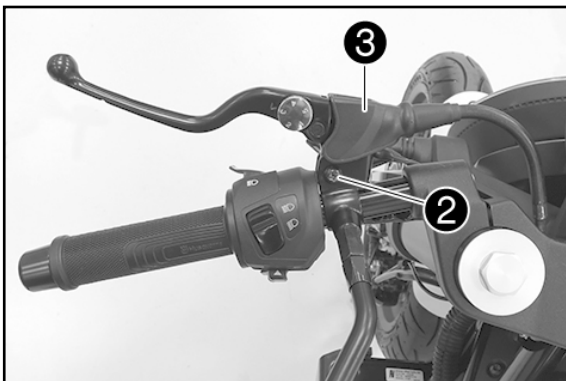

- Retirer les vis ④.
- Mettre le contacteur d'embrayage de côté.

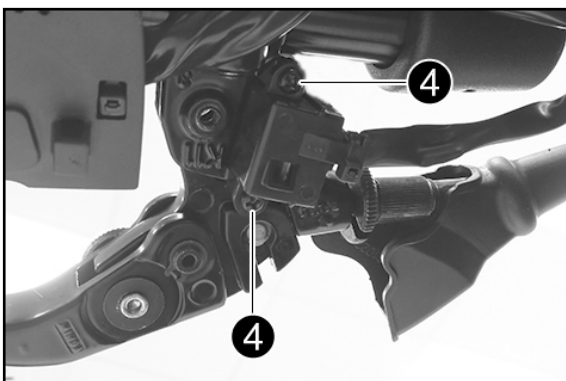

- Décrocher le câble d'embrayage ⑤.



- Mettre en place le contacteur d'embrayage.
- Mettre les vis ④ en place et les serrer.

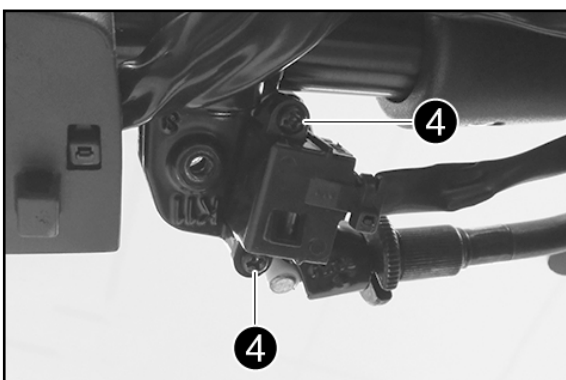

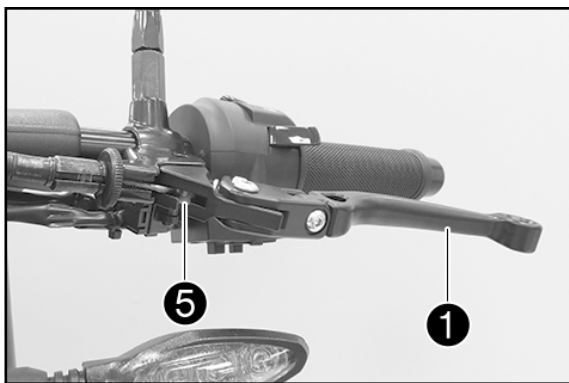

- Mettre en place le levier d'embrayage ① (fourni).
- Accrocher le câble d'embrayage ⑤.

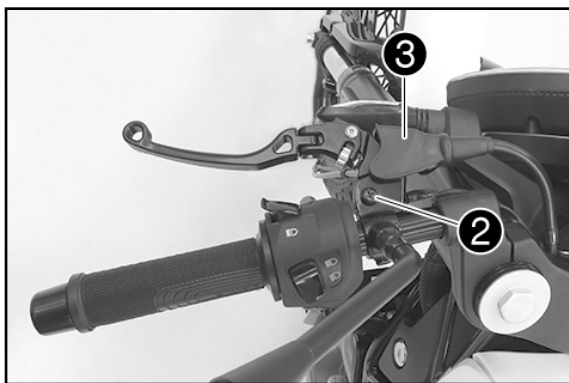

- Mettre en place le raccord vissé ② et le serrer à 8 Nm.
- Mettre en place le cache-poussière ③.

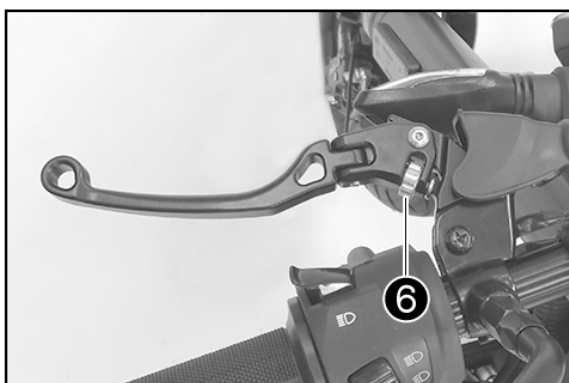

- À l'aide de la molette de réglage ⑥, adapter la position de base du levier d'embrayage à la taille de la main du pilote.

#### REMARQUE

Pousser le levier de frein à main vers l'avant et tourner la molette de réglage.

Ne pas effectuer de travaux de réglage durant le trajet.

#### ! ATTENTION

**Veiller à ce que le levier soit monté correctement !**

**Avant la première utilisation, vérifier le fonctionnement de l'embrayage !**

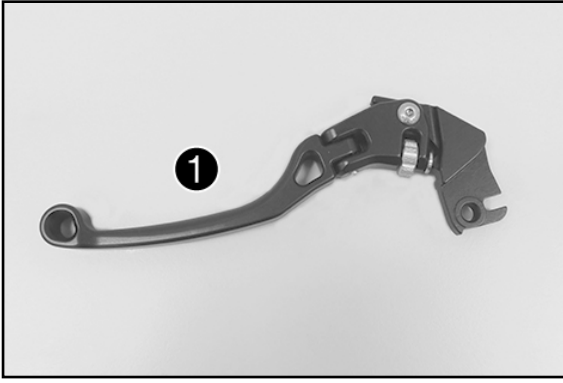

### Volumen de suministro

1x maneta de embrague ❶

### ADVERTENCIA

Se volverán a utilizar todos los tornillos y tuercas de la maneta original.

Antes de empezar el montaje, estas piezas deben limpiarse bien y engrasarse.

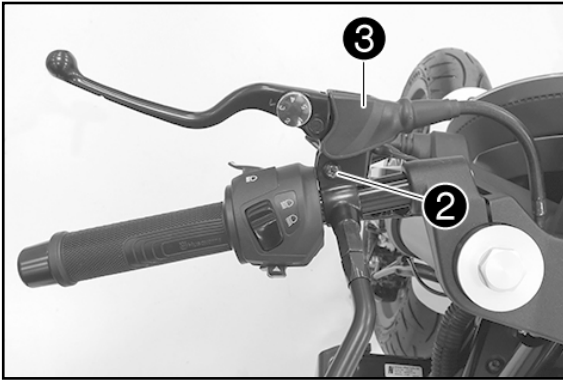

### Montaje

- Retirar la unión atornillada ❷.
- Retraer el manguito ❸.

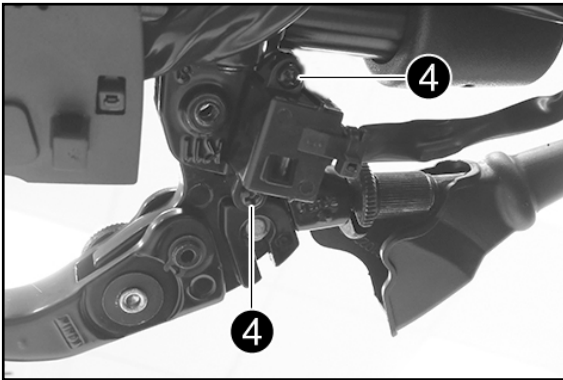

- Retirar los tornillos ❹.
- Dejar el interruptor de embrague colgando de un lado.

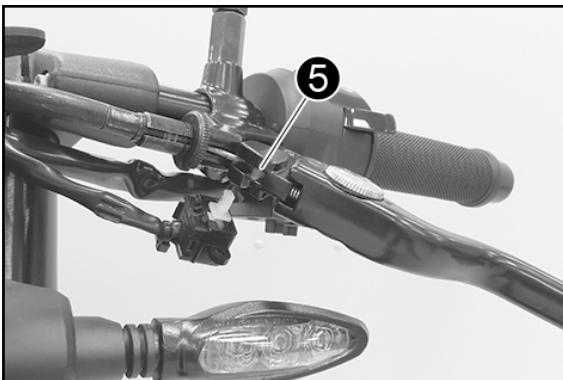

- Desenganchar el latiguillo del embrague ❺.

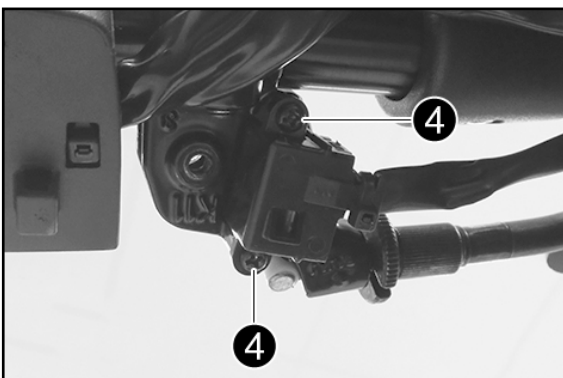

- Colocar el interruptor de embrague.
- Montar y apretar los tornillos ❹.

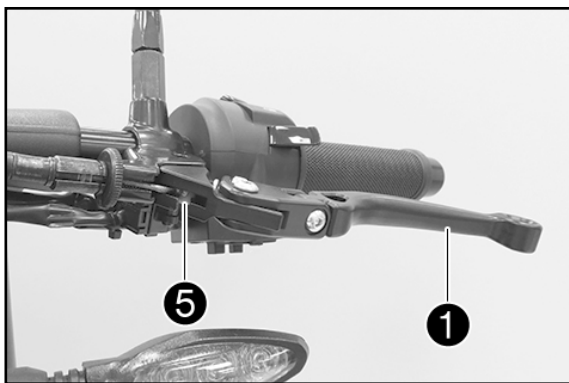

- Posicionar la maneta de embrague ① (volumen de suministro).
- Enganchar el latiguillo del embrague ⑤.

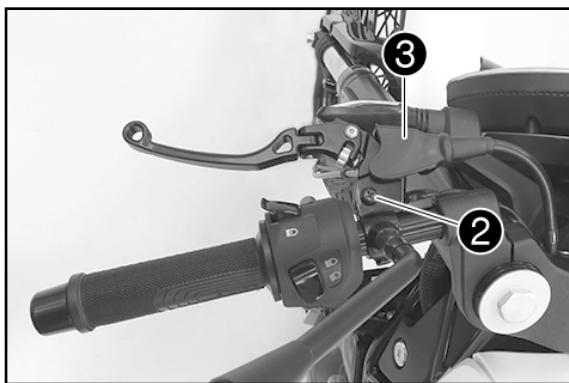

- Montar la unión atornillada ② y apretarla a 8 Nm.
- Colocar el manguito ③.

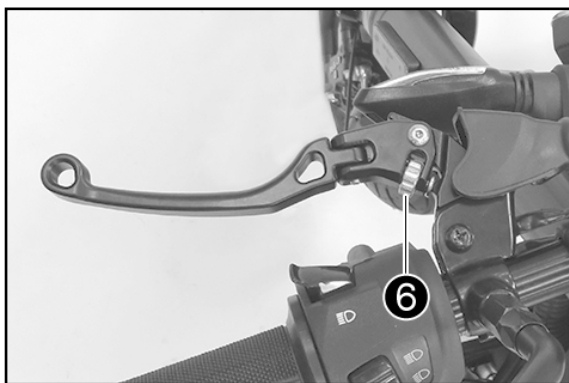

- Adaptar la posición básica de la maneta de embrague al tamaño de la mano con el mando de ajuste ⑥.

#### ADVERTENCIA

Empujar la maneta de freno hacia delante y girar el mando de ajuste.

No realizar los ajustes durante la conducción.

#### ! AVISO

Prestar atención a que las manetas queden montadas correctamente.

Antes de volver a utilizar la motocicleta, debe comprobarse que el embrague funcione correctamente.