

OWNER'S MANUAL

XPLOR PRO 7548 790 ADVENTURE R

Art. no. 53000181en



Congratulations on your decision to purchase a WP chassis component. You are now the owner of a state-of-the-art sports chassis that you will continue to enjoy for a long time if you maintain it properly.

We wish you good and safe riding at all times!

The Owner's Manual contained the latest information for this model series at the time of going to print. However, minor differences due to further developments in design cannot be ruled out completely.

All specifications contained herein are non-binding. WP Suspension GmbH specifically reserves the right to modify or delete technical specifications, prices, colors, forms, materials, services, designs, equipment, etc., without prior notice and without providing reasons, to adapt these to local conditions, as well as to stop the production of a particular model without prior notice. WP accepts no liability for delivery options, deviations from figures and descriptions, misprints, and other errors. The models portrayed partly contain special equipment that does not belong to the regular scope of supply.

© 2019 WP Suspension GmbH, Mattighofen Austria

All rights reserved

Reproduction, even in part, as well as copying of all kinds, is permitted only with the express written permission of the copyright owner.



WP Suspension GmbH
Stallhofnerstraße 3
5230 Mattighofen, Austria

This document is valid for the following models:

XPLOR PRO 7548 790 Adventure R (14.18.2S.08)



TABLE OF CONTENTS

1	MEANS OF REPRESENTATION.....	3	8.9	Taking the motorcycle off the front lifting gear	15
1.1	Symbols used	3	8.10	Removing the rear of the motorcycle from the lifting gear	16
1.2	Formats used	3	9	TUNING THE CHASSIS.....	17
2	SAFETY ADVICE	4	9.1	Checking the basic chassis setting with rider's weight.....	17
2.1	Use definition – intended use	4	9.2	Checking the basic setting of the fork.....	17
2.2	Misuse.....	4	9.3	Adjusting the compression damping of the fork.....	17
2.3	Safety advice	4	9.4	Adjusting the rebound damping of the fork.....	18
2.4	Degrees of risk and symbols	4	9.5	Adjusting the spring pretension of the fork.....	19
2.5	Safe operation.....	5	10	TECHNICAL DATA	20
2.6	Work rules.....	5	10.1	Fork.....	20
2.7	Environment.....	5	11	SUBSTANCES.....	21
2.8	Owner's Manual.....	5	12	AUXILIARY SUBSTANCES.....	22
2.9	Correct installation.....	5	13	STANDARDS.....	23
2.10	Chassis tightening torques	6	14	INDEX OF SPECIAL TERMS	24
3	IMPORTANT NOTES.....	7	15	LIST OF ABBREVIATIONS	25
3.1	Manufacturer and implied warranty	7	INDEX.....		26
3.2	Fuel, auxiliary substances.....	7			
3.3	Spare parts, accessories	7			
3.4	Service	7			
3.5	Figures	7			
3.6	Customer service.....	7			
4	SERIAL NUMBERS.....	8			
4.1	Fork article number.....	8			
5	PREPARING FOR USE.....	9			
5.1	Advice on preparing for first use.....	9			
6	RIDING INSTRUCTIONS	10			
6.1	Checks and maintenance measures when preparing for use.....	10			
7	SERVICE SCHEDULE.....	11			
7.1	Additional information.....	11			
7.2	Required work.....	11			
7.3	Recommended work.....	11			
8	SERVICE WORK ON THE CHASSIS	12			
8.1	Removing the standard fork legs 	12			
8.2	Installing the WP PRO COMPONENTS fork legs 	12			
8.3	Bleeding the fork legs	12			
8.4	Removing the front fender	13			
8.5	Installing the front fender	13			
8.6	Cleaning the dust boots of the fork legs	14			
8.7	Raising the motorcycle with rear lifting gear	14			
8.8	Lifting the motorcycle with the front lifting gear	15			

1.1 Symbols used

The meaning of specific symbols is described below.



Indicates an expected reaction (e.g. of a work step or a function).



Indicates an unexpected reaction (e.g. of a work step or a function).



All work marked with this symbol requires specialist knowledge and technical understanding. In the interest of your own safety, have these jobs performed by a WP Authorized Center! There your WP chassis will be treated with the optimum care and attention by specially trained experts using the necessary special tools.



Indicates a page reference (more information is provided on the specified page).



Indicates information with more details or tips.



Indicates the result of a testing step.



Indicates the end of an activity, including potential rework.

1.2 Formats used

The typographical formats used in this document are explained below.

Proprietary name

Indicates a proprietary name.

Name[®]

Indicates a protected name.

Brand[™]

Indicates a brand available on the open market.

Underlined terms

Refer to technical details or indicate technical terms, which are explained in the glossary.

2.1 Use definition – intended use

This chassis component is designed and built to withstand the normal stresses and strains of regular racing.



Info

Only use this chassis component in closed-off areas remote from public road traffic. Your WP Authorized Center can inform you whether a factory approval for use on public roads may have been issued for your chassis components. Only use this chassis component in the vehicle for which the chassis component is approved and/or recommended.

2.2 Misuse

The chassis component must only be used as intended. Dangers can arise for people, property and the environment through use not as intended. Any use of the chassis component beyond the intended and defined use constitutes misuse. Misuse also includes the use of operating and auxiliary fluids which do not meet the required specification for the respective use.

2.3 Safety advice

A number of safety instructions need to be followed to operate the product described safely. Therefore read this instruction and all further instructions included carefully. The safety instructions are highlighted in the text and are referred to at the relevant passages.



Info

Various information and warning labels are attached in prominent locations on the product described. Do not remove any information or warning labels. If they are missing, you or others may not recognize dangers and may therefore be injured.

2.4 Degrees of risk and symbols



Danger

Identifies a danger that will immediately and invariably lead to fatal or serious permanent injury if the appropriate measures are not taken.



Warning

Identifies a danger that is likely to lead to fatal or serious injury if the appropriate measures are not taken.

Note

Identifies a danger that will lead to considerable machine and material damage if the appropriate measures are not taken.

2.5 Safe operation



Danger

Danger of accidents A rider who is not fit to ride poses a danger to him or herself and others.

- Do not operate the vehicle and use chassis components if you are not fit to ride due to alcohol, drugs or medication.
- Do not operate the vehicle and use chassis components if you are physically or mentally impaired.

Only use the chassis component when it is in perfect technical condition, in accordance with its intended use, and in a safe and environmentally compatible manner.

If there are faults, which impair safety, have them immediately remedied in a WP Authorized Center.

Adhere to the information and warning labels on the chassis component.

2.6 Work rules

Special tools are necessary for certain tasks. The tools are not a component of the chassis component, but can be ordered using the number in parentheses.

During assembly, use new parts to replace parts which cannot be reused (e.g., seals, seal rings, O-rings).

In the case of certain screws, a thread locker (e.g. **Loctite**[®]) is required. Observe the manufacturer's instructions.

After disassembly, clean the parts that are to be reused and check them for damage and wear. Change damaged or worn parts.

After completing a repair or service work, check the operating safety of the chassis component.

2.7 Environment

If you use your chassis component responsibly, you can ensure that problems and conflicts do not occur.

When disposing of used oil, other operating and auxiliary fluids, and used components, comply with the laws and regulations of the respective country.

2.8 Owner's Manual

It is important that you read this Owner's Manual carefully and completely before making your first trip. The Owner's Manual contains useful information and many tips on how to operate, handle, and service your motorcycle. This is the only way for you to find out how to set up the chassis component ideally and how to protect yourself from injury.

Keep the Owner's Manual in an accessible place to enable you to refer to it as needed.

If you would like to know more about the chassis component or have questions on the material you read, please contact a WP Authorized Center.

The Owner's Manual is an important part of the chassis component and must be handed over to the new owner if the vehicle is sold.

2.9 Correct installation

Correct installation in the same way as for the original components and in accordance with the repair manual of the vehicle is essential for ensuring maximum safety and functionality.

It is therefore strongly recommended that you have the chassis component installed at a WP Authorized Center.

2.10 Chassis tightening torques

Unless otherwise stated, the tightening torques specified in the operating and repair manual apply for the vehicle.

3.1 Manufacturer and implied warranty

The work prescribed in the service schedule must be carried out in a WP Authorized Center only, since otherwise no warranty claims will be recognized. Damage or secondary damage caused by tampering with and/or conversions on the chassis component are not covered by the warranty.

3.2 Fuel, auxiliary substances

Use operating and auxiliary substances (such as fuel and lubricants) as specified in the Owner's Manual.

3.3 Spare parts, accessories

For your safety, only use spare parts and accessory products that are approved and/or recommended by WP and have them installed in a WP Authorized Center. WP accepts no liability for other products and any resulting damage or loss.

Certain spare parts and accessory products are specified in parentheses in the descriptions. Your WP Authorized Center will be pleased to advise you.

3.4 Service

A prerequisite for perfect operation and prevention of premature wear is that the service, care, and tuning work is properly carried out as described in the Owner's Manual. Incorrect adjustment and tuning of the chassis and suspension can lead to damage and breakage of components.

Use of the chassis component under difficult conditions, such as on sand or on wet and muddy surfaces, can lead to considerably more rapid wear. For this reason, it may be necessary to inspect or replace parts before the next scheduled service.

It is imperative that you adhere to the stipulated service intervals. If you observe these exactly, you will ensure a much longer service life for your chassis component.

3.5 Figures

The figures contained in the manual may depict special equipment.

In the interest of clarity, some components may be shown disassembled or may not be shown at all. It is not always necessary to disassemble the component to perform the activity in question. Please follow the instructions in the text.

3.6 Customer service

If you have any questions about your chassis component or WP, your WP Authorized Center will be pleased to advise you.

A list of WP Authorized Centers can be found on the WP website.

International WP Suspension website: <http://www.wp-suspension.com>

4 SERIAL NUMBERS

4.1 Fork article number

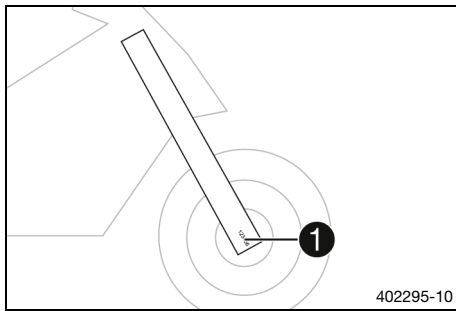

The fork article number **1** is stamped on the inside of the axle clamp.

i **Info**

The fork article number consists of an eight figure number with a single letter in the sixth position.

5.1 Advice on preparing for first use



Warning

Danger of accident Modifications to the suspension setting may seriously alter the handling characteristic.

Extreme modifications to the suspension setting may cause a serious deterioration in the handling characteristic and overload components.

- Only make adjustments within the recommended range.
 - Ride slowly to start with after making adjustments to get the feel of the new handling characteristic.
-
- Adjust the compression damping of the fork. (📖 p. 17)
 - Adjust the rebound damping of the fork. (📖 p. 18)
 - Adjust the spring preload of the fork. (📖 p. 19)



6.1 Checks and maintenance measures when preparing for use

i Info

Before every use, check the condition of the chassis component and ensure that it is safe to operate. The chassis must be in perfect technical condition when it is being operated.

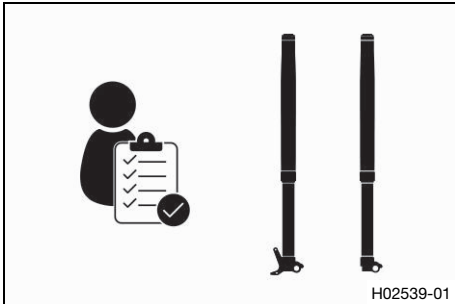

- Check chassis component for damage.
- Clean the dust boots of the fork legs. (📖 p. 14)
- Bleed the fork legs. (📖 p. 12)
- Check all screw connections to ensure that they are tight.

7.1 Additional information

Any further work that results from the compulsory work or from the recommended work must be ordered separately and invoiced separately.

Different service intervals may apply in your country, depending on the local operating conditions.

7.2 Required work

Every 40 operating hours every 20,000 km (12,400 mi)	
Conducting fork service (offroad use). 🐾	•
Conducting fork service (road use). 🐾	•

- Periodic interval

7.3 Recommended work

After 20 operating hours after 5,000 km (3,100 mi)	
Conducting fork service (offroad use). 🐾	○
Conducting fork service (road use). 🐾	○

- One-time interval

8 SERVICE WORK ON THE CHASSIS

8.1 Removing the standard fork legs ↴

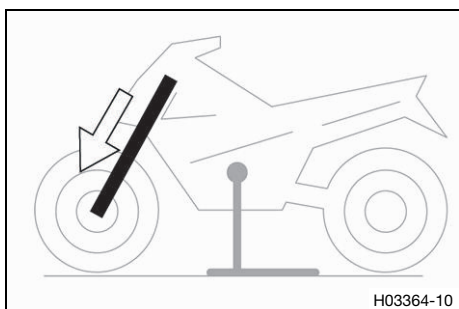

- Remove the standard fork legs according to the repair manual.

8.2 Installing the WP PRO COMPONENTS fork legs ↴

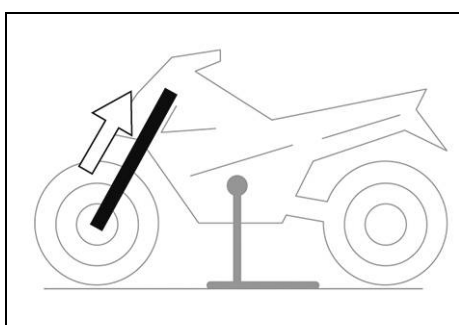

- Install the fork legs according to the repair manual.

Guideline

Observe the installation position of the milled grooves to the upper edge of the upper triple clamp.

2nd groove from the top

- ✓ Bleeder screws ❶ are positioned toward the front.
- Attach the stickers (included).

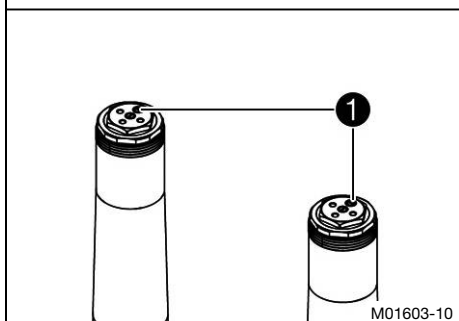

8.3 Bleeding the fork legs

Preparatory work

- Raise the motorcycle with the rear lifting gear. (📖 p. 14)
- Remove the front fender. (📖 p. 13)
- Lift the motorcycle with the front lifting gear. (📖 p. 15)

Main work

- Release bleeder screws ❶.
- ✓ Any excess pressure escapes from the interior of the fork.
- Tighten the bleeder screws.

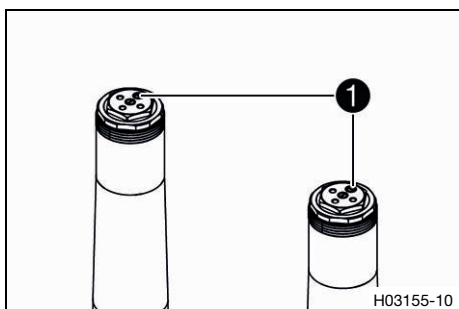

Finishing work

- Take the motorcycle off the front lifting gear. (📖 p. 15)
- Install the front fender. (📖 p. 13)

- Remove the rear of the motorcycle from the lifting gear. (📖 p. 16)



8.4 Removing the front fender

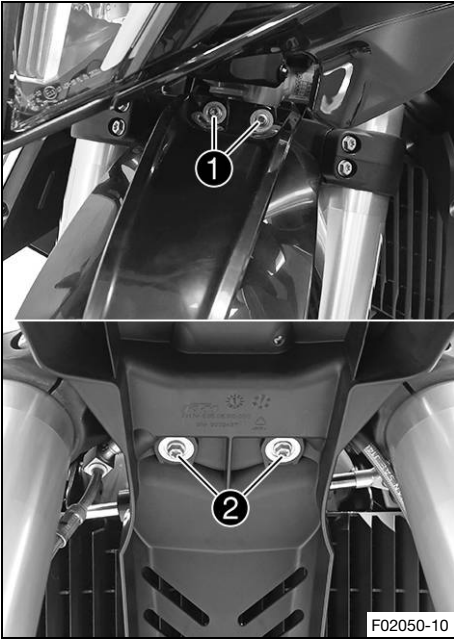

- Remove screws ①.
- Remove screws ②.
- Take the fender off to the front.



8.5 Installing the front fender

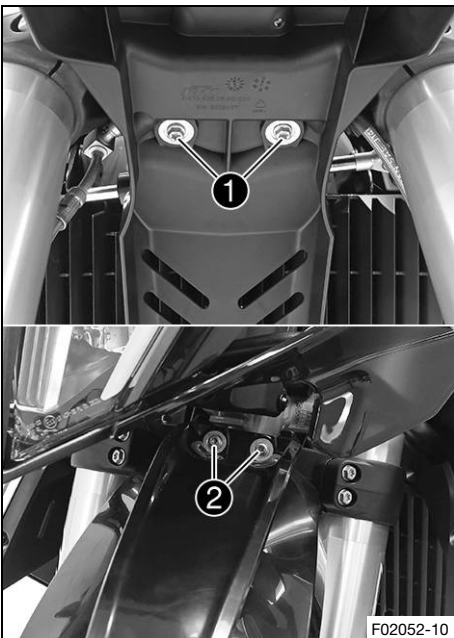

- Position the front fender. Mount screws ①, but do not tighten yet.

Guideline

Remaining screws, chassis	M6	10 Nm (7.4 lbf ft)
---------------------------	----	--------------------

- Mount screws ②, but do not tighten yet.

Guideline

Remaining screws, chassis	M6	10 Nm (7.4 lbf ft)
---------------------------	----	--------------------

✓ The fender is evenly aligned to the front.

- Tighten all screws on the front fender.

Guideline

Remaining screws, chassis	M6	10 Nm (7.4 lbf ft)
---------------------------	----	--------------------



8.6 Cleaning the dust boots of the fork legs

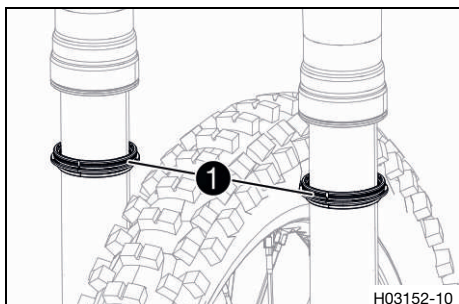

Preparatory work

- Raise the motorcycle with the rear lifting gear. (📖 p. 14)
- Remove the front fender. (📖 p. 13)
- Lift the motorcycle with the front lifting gear. (📖 p. 15)

Main work

- Push dust boots ❶ of both fork legs downward.

Info

The dust boots remove dust and coarse dirt particles from the inside fork tubes. Over time, dirt can accumulate behind the dust boots. If this dirt is not removed, the oil seals behind can start to leak.



Warning

Danger of accidents Oil or grease on the brake discs reduces the braking effect.

- Always keep the brake discs free of oil and grease.
- Clean the brake discs with brake cleaner when necessary.

- Clean and oil the dust boots and inner fork tubes of both fork legs.

Universal oil spray (📖 p. 22)

- Press the dust boots back into the installation position.
- Remove the excess oil.

Finishing work

- Take the motorcycle off the front lifting gear. (📖 p. 15)
- Install the front fender. (📖 p. 13)
- Remove the rear of the motorcycle from the lifting gear. (📖 p. 16)

8.7 Raising the motorcycle with rear lifting gear

Note

Danger of damage The parked vehicle can roll away or fall over.

- Park the vehicle on a firm and level surface.

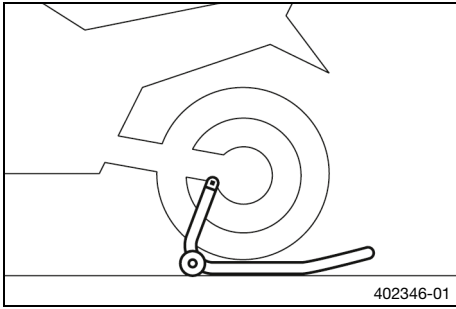

- Mount retaining adapter on the link fork.
- Insert the adapter in the rear lifting gear.

Retaining adapter (61029955144)
Rear wheel work stand (69329955000)

- Stand motorcycle upright, align lifting gear to the link fork with the adapters, and raise motorcycle.



8.8 Lifting the motorcycle with the front lifting gear

Note

Danger of damage The parked vehicle can roll away or fall over.

- Park the vehicle on a firm and level surface.

Preparatory work

- Raise the motorcycle with the rear lifting gear. (📖 p. 14)
- Remove the front fender. (📖 p. 13)

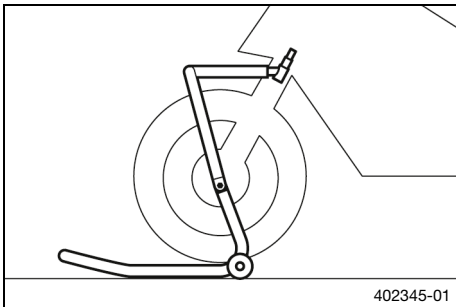

Main work

- Move the handlebar to the straight-ahead position.
- Attach the front lifting gear with the adapters on the steering stem.

Mounting pin (69329965040)
Front wheel work stand, large (69329965100)

- Align the front lifting gear with the fork legs.



Info

Always raise the motorcycle at the rear first.

- Lift the motorcycle at the front.



8.9 Taking the motorcycle off the front lifting gear

Note

Danger of damage The parked vehicle can roll away or fall over.

- Park the vehicle on a firm and level surface.

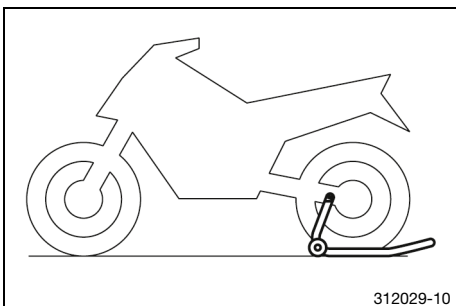

Main work

- Secure the motorcycle against falling over.
- Remove the front lifting gear.

Finishing work

- Install the front fender. (📖 p. 13)



8.10 Removing the rear of the motorcycle from the lifting gear

Note

Danger of damage The parked vehicle can roll away or fall over.

- Park the vehicle on a firm and level surface.

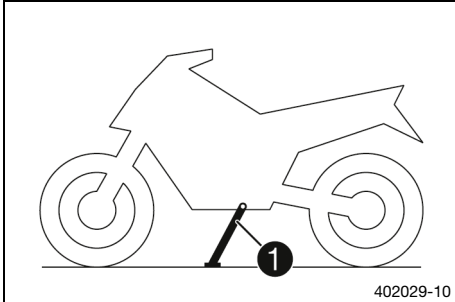

- Secure the motorcycle against falling over.
- Remove the rear lifting gear and lean the vehicle on side stand ①.
- Remove the retaining adapter from the link fork.

9.1 Checking the basic chassis setting with rider's weight

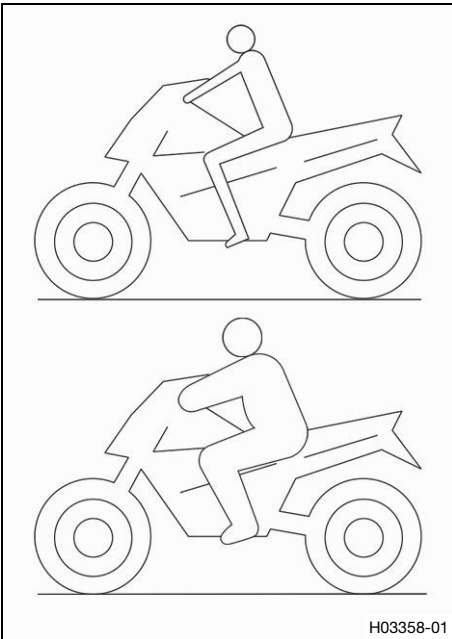

- For optimal motorcycle riding characteristics and to avoid damage to forks, shock absorbers, link fork and frame, the basic settings of the suspension components must match the rider's weight.

- This chassis component is factory set to a standard rider's weight.

Guideline

Standard rider weight	75 ... 85 kg (165 ... 187 lb.)
-----------------------	--------------------------------

- If the rider's weight is above or below this range, the basic setting of the suspension components must be adjusted accordingly.
- Minor differences in the rider's weight can be compensated for by modifying the spring preload.
- In case of larger differences, appropriate springs must be fitted.



Info

Suitable springs are available from a WP Authorized Center.



9.2 Checking the basic setting of the fork



Info

For various reasons, no exact riding sag can be determined for the fork.

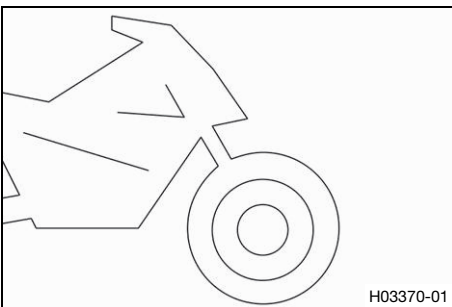

- As with the shock absorber, smaller differences in the rider's weight can be compensated by the spring preload.
- However, if the fork frequently bottoms out (hard end stop on compression), harder springs must be fitted to avoid damage to the fork and frame.
- If the fork feels unusually hard after extended periods of operation, the fork legs need to be bled.



9.3 Adjusting the compression damping of the fork



Info

The hydraulic compression damping determines the fork suspension behavior.

9 TUNING THE CHASSIS

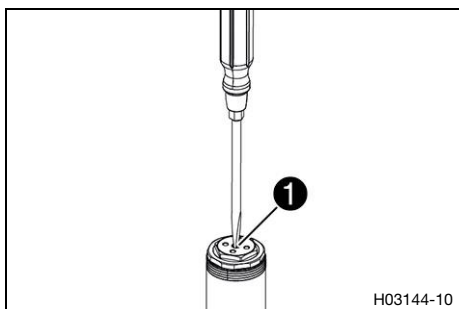

- Turn adjusting screws **1** clockwise up to the last perceptible click.

i Info
The adjusting screws are located at the top end of the fork legs.
Make the same adjustment on both fork legs.
A screwdriver is shown for better illustration, an adjustment tool is included in the scope of delivery.

- Turn counterclockwise by the number of clicks corresponding to the fork type.

Guideline

Compression damping	
Comfort	16 clicks
Standard	12 clicks
Sport	10 clicks
Full payload	8 clicks

i Info
Turn clockwise to increase damping; turn counterclockwise to reduce damping.

9.4 Adjusting the rebound damping of the fork

i Info
The hydraulic rebound damping determines the fork suspension behavior.

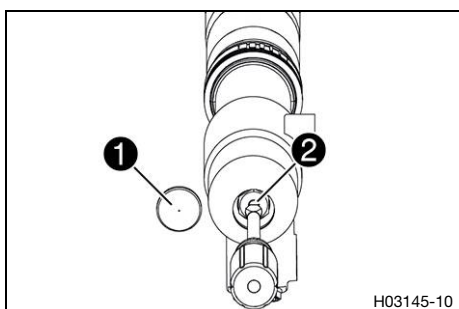

- Take off protection caps **1**.
- Turn adjusting screws **2** clockwise up to the last perceptible click.

i Info
The adjusting screws are located at the bottom end of the fork legs.
Make the same adjustment on both fork legs.

- Turn counterclockwise by the number of clicks corresponding to the fork type.

Guideline

Rebound damping	18 clicks
-----------------	-----------

i Info
Turn clockwise to increase damping; turn counterclockwise to reduce damping.

- Mount protection caps **1**.

9.5 Adjusting the spring pretension of the fork

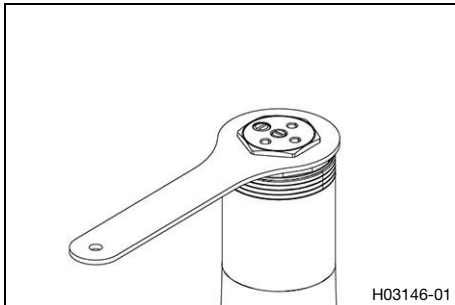

Preparatory work

- Raise the motorcycle with the rear lifting gear. (📖 p. 14)
- Remove the front fender. (📖 p. 13)
- Lift the motorcycle with the front lifting gear. (📖 p. 15)

Main work

- Turn the **Preload Adjuster** counterclockwise to the last perceptible click.

Adjusting spanner (T14028)

i Info

The adjusting spanner is included.
Make the same adjustment on both fork legs.

- Turn clockwise by the number of clicks, corresponding to the fork type.

Guideline

Spring preload - Preload Adjuster	
Comfort	6 clicks
Standard	10 clicks
Sport	12 clicks
Full payload	16 clicks

- ✓ The **Preload Adjuster** engage noticeably.

i Info

Adjust the spring preload only to the perceptible clicks, as the preload will not engage between clicks. Turn clockwise to increase the spring preload; turn counterclockwise to reduce the spring preload. Adjusting the spring preload has no influence on the absorption setting of the rebound. Basically, however, you should set the rebound damping higher with a higher spring preload.

Finishing work

- Take the motorcycle off the front lifting gear. (📖 p. 15)
- Install the front fender. (📖 p. 13)
- Remove the rear of the motorcycle from the lifting gear. (📖 p. 16)



10.1 Fork

Fork article number	14.18.2S.08	
Fork	XPLOR PRO 7548	
Compression damping		
Comfort	16 clicks	
Standard	12 clicks	
Sport	10 clicks	
Full payload	8 clicks	
Rebound damping	18 clicks	
Spring preload - Preload Adjuster		
Comfort	6 clicks	
Standard	10 clicks	
Sport	12 clicks	
Full payload	16 clicks	
Spring rate		
Weight of rider: 55 ... 65 kg (121 ... 143 lb.)	6.6 N/mm (37.7 lb/in)	
Weight of rider: 65 ... 75 kg (143 ... 165 lb.)	6.8 N/mm (38.8 lb/in)	
Weight of rider: 75 ... 85 kg (165 ... 187 lb.)	7.0 N/mm (40 lb/in)	
Weight of rider: 85 ... 95 kg (187 ... 209 lb.)	7.2 N/mm (41.1 lb/in)	
Spring length with preload spacer(s)	488 mm (19.21 in)	
Fork length	912 mm (35.91 in)	
Oil capacity external mechanism left	480 ml (16.23 fl. oz.)	Fork oil (SAE 4) (48601166S1) (📖 p. 21)
Oil capacity external mechanism right	480 ml (16.23 fl. oz.)	Fork oil (SAE 4) (48601166S1) (📖 p. 21)
Oil capacity, left cartridge	170 ml (5.75 fl. oz.)	Fork oil (SAE 4) (48601166S1) (📖 p. 21)
Oil capacity, right cartridge	170 ml (5.75 fl. oz.)	Fork oil (SAE 4) (48601166S1) (📖 p. 21)

Fork oil (SAE 4) (48601166S1)**Standard/classification**

- SAE (📖 p. 23) (SAE 4)

Guideline

- Use only oils that comply with the specified standards (see specifications on the container) and that exhibit the corresponding properties.

Universal oil spray

Recommended supplier

MOTOREX®

– Joker 440 Synthetic

SAE

The SAE viscosity classes were defined by the Society of Automotive Engineers and are used for classifying oils according to their viscosity. The viscosity describes only one property of oil and says nothing about quality.

14 INDEX OF SPECIAL TERMS

PA	Preload adjuster	Device on the suspension components that enables the adjustment of the spring preload
----	------------------	---

Art. no.	Article number
ca.	circa
cf.	compare
e.g.	for example
etc.	et cetera
i.a.	inter alia
no.	number
poss.	possibly

A

Accessories	7
Auxiliary substances	7

B

Basic chassis setting

checking with rider's weight	17
------------------------------	----

C

Correct installation	5
Customer service	7

E

Environment	5
-------------	---

F

Figures	7
---------	---

Fork

article number	8
basic setting, checking	17
compression damping, adjusting	17
rebound damping, adjusting	18

Fork legs

bleeding	12
dust boots, cleaning	14
spring preload, adjusting	19
standard version, removing	12
WP PRO COMPONENTS version, installing	12

Front fender

installing	13
removing	13

Fuel, oils, etc.	7
------------------	---

I

Implied warranty	7
Intended use	4

M

Misuse	4
--------	---

Motorcycle

lifting gear, raising with at rear	14
lifting gear, removing at the rear	16
lifting with front lifting gear	15
taking off front lifting gear	15

O

Owner's Manual	5
----------------	---

P

Preparing for use

advice on preparing for first use	9
checks and maintenance measures when preparing for use	10

S

Safe operation	5
Service	7
Service schedule	11
Spare parts	7

T

Technical data

chassis tightening torques	6
fork	20

U

Use definition	4
----------------	---

W

Warranty	7
Work rules	5



53000181en

03/2019

